

# Operation and Maintenance Manual

## R Series

### Positive Displacement Pump



Read and understand this manual prior to operating or servicing this product.

**APV**  
**Instruction and Parts Manual**

---

**‘R’ Series Rotary Pump**

Model Number \_\_\_\_\_  
Serial Number \_\_\_\_\_  
Order Number \_\_\_\_\_  
General Assembly Number \_\_\_\_\_

**Cover Body**

\_\_\_\_ Side Inlet/Outlet  
\_\_\_\_ Front Outlet (Std)  
\_\_\_\_ Front Outlet (HD)  
\_\_\_\_ Rectangular Inlet  
\_\_\_\_ Vented  
\_\_\_\_ Top Feed  
\_\_\_\_ Degassing/Deaerating  
\_\_\_\_ Full-Flow Bypass

**Rotors**

\_\_\_\_ Number of Lobes  
\_\_\_\_ Flush Face  
\_\_\_\_ Recessed Face  
\_\_\_\_ Undersize  
\_\_\_\_ Oversize

**Pump Shaft Seal Color Code**

\_\_\_\_ White  
\_\_\_\_ Blue  
\_\_\_\_ Red  
\_\_\_\_ Green  
\_\_\_\_ Two Orange

**Accessory Tools**

\_\_\_\_ Spanner Wrench 0, 1, 2  
\_\_\_\_ Spanner Wrench 3, 4, 6  
\_\_\_\_ Rotor Puller 0  
\_\_\_\_ Rotor Puller – Three-Prong 1, 2, 3  
\_\_\_\_ Rotor Puller – Solid Plastic Rotor 3, 4, 6  
\_\_\_\_ Rotor Puller & Special Wrench 3, 4, 6

**Cover Gasket Material**

\_\_\_\_ Paper  
\_\_\_\_ Specials

**Rotor Material**

\_\_\_\_ Nitrile Rubber (Std)  
\_\_\_\_ EPDM Rubber  
\_\_\_\_ Celcon  
\_\_\_\_ Solid Epoxy  
\_\_\_\_ Solid Metal  
\_\_\_\_ PPS

**Pump Shaft Seal Type**

\_\_\_\_ Pressure Vacuum (Std)  
\_\_\_\_ Pressure  
\_\_\_\_ Single Mechanical  
\_\_\_\_ Water Flush  
\_\_\_\_ Specials

**Hub Materials**

\_\_\_\_ Stainless Steel  
\_\_\_\_ Epoxy  
\_\_\_\_ Seal Inserter Assembly 0, 1, 2  
\_\_\_\_ Seal Inserter Assembly 3  
\_\_\_\_ Seal Inserter Assembly 4, 6, 700  
\_\_\_\_ Heavy-Duty Rotor Puller 4HD, 6HD, 700  
\_\_\_\_ Socket Wrench – “T” Handle 1, 2

Spares & Service Parts  
Tel: 888-278-4321 / Fax: 888-278-5329

03WP469240  
A-1-500-700  
(Rev. 8)

# Table of Contents

<b>Introduction</b>	3	<b>Shaft Seal Insertion Procedure</b>	47
<b>Standard Warranty</b>	4	Rotors and Shafts	49
A Word About APV Service Parts	5	Removing Two-Lobe Rotors (R0 Pump Only)	49
Rotor Exchange Program	6	Removing Rotors with Three-Prong Tool (R1, R2 and R3HD Pumps)	49
<b>Safety Information</b>	7	Removing Rotors with Star Wrench (R3, R4 and R6 Pumps)	49
Definitions	8	Removing Rotors with Heavy-Duty Puller (R4HD, R6HD and R700 Pumps)	49
Safety Decals	9	<b>Shaft Wear</b>	50
Electrical Hazard	10	Field Reconditioning	51
Mechanical Hazard	10	Preventative Maintenance Check List	52
Cleaning/Sanitizing Chemical Hazard	11	Rotary Pump Maintenance Tips	53
High Temperature Hazard	11	<b>Options</b>	
High Pressure Hazard	12	Vented Cover	54
Leaking Fluid Hazard	12	Field Installation	54
<b>Important Cautions</b>	13	Cleaning	54
Corrosion Pitting	13	Manual	55
Motor Overload	13	Adjusting Vented Cover – Manual Operation	55
Cavitation	13	Adjusting Venter Cover – Pneumatic Operation	56
<b>General Information</b>	14	Water Flush Seal Kit	57
Components and Services Furnished by the Customer	14	Flanged Hopper Rectangular Inlet	58
Sanitary Design	14	Installation & Cleaning	58
Receiving and Inspection	14	Degasser – Deaerator	59
General	15	Product Flow	59
Specifications	16	APV Options	60
Available Design Features	17	<b>Service Parts</b>	
Special Pump Types	18	Model R0	61
Rotors	19	Models R1, R2, R3 and R3HD	64
Rotor Pullers	26	Models R2RI, R3RI and R3HDRI	68
Clearance for Particulates	28	Models R4 and R6	72
Pump Shaft Seal Identification	29	Models R4RI and R6RI	76
<b>Installation</b>	30	Models R4HD and R6HD	81
Selecting Unit Location	30	Models R4HDRI, R6HDRI	86
Gear Case Oil	30	Models R700HD	92
Rotation Check	30	Models R700HDRI	97
Drive Unit Recommendations	31	<b>Vented Cover Option</b>	
Torque Limited Drivers	31	Models R1, R2, R2RI, R3, R3RI, R3HD and R3HDRI	111
<b>Cleaning and Sanitizing</b>	32	Models R4, R4RI, R6, R6RI	112
Initial Cleaning	32	<b>Water Flush Seal Kit</b>	
Cleaning Tips	32	Models R1, R2, R2RI, R3, R3RI, R3HD, 3HDRI	113
Daily Procedure for R0 Pumps	32	Models R4, R4RI, R6 and R6RI	114
Daily Procedure for R1, R2, R3, R3HD, R4, R4HD, R6 and R6HD Pumps	33	Models R4, R4RI, R6 and R6RI - Top Feed	115
Daily Procedure for R4HDRI, R6HDRI, R700RI, R700HDRI, R4BHDRI, R6BHDRI and R700BHDRI pumps	34	Models R4HD, R6HD and R700HD	116
<b>Theory of Operation</b>	37	Models R700, R700HD Top Feed and R700RI	117
<b>Operation</b>	38	<b>Shaft Seals</b>	
Starting and Stopping the Pump	38	Heavy Duty Cover Seal options	118
<b>Maintenance</b>	39	Standard shaft seals	120
Lubrication	39	Rotors	121
Checking, Adding & Changing Oil	40	<b>Tools</b>	126
Roller Bearing Adjustment (R0 Pump Only)	41	<b>Recommended Inventory</b>	127
Roller Bearing Adjustment (All Pumps Except R0 Pump)	42		
Gear Case (R0 Pump Only) Disassembly	43		
Gear Case (R0 Pump Only) Assembly	44		
Gear Case (All Pumps Except R0 Pump) Disassembly	45		
Gear Case (All Pumps Except R0 Pump) Assembly	46		
Oil Seal Replacement and Relocation (R0 Pump Only)	47		

---

## Introduction

---

Congratulations, you are the owner of a quality built item of APV. This equipment was manufactured by the skilled personnel of a company which has served the needs of the dairy, food and process industries for more than 150 years.

The purpose of this manual is to provide instructions for the safe installation, operation and maintenance of your APV equipment.

**Read and understand the entire manual before removing from the crate and installing the equipment.**

APV is committed to provide quality equipment and customer satisfaction. We have a unique network of sales and service support throughout the world (see the office listing at the back of this manual). Should you have any questions concerning any information contained in this manual, contact the nearest office to you or our Delavan, Wisconsin office for assistance.

---

## Standard Warranty

---

### Obligations of Seller

During the warranty period, Seller shall repair, or at Seller's option, replace parts determined by Seller to be defective in material or workmanship. The warranty period is one (1) year from the date of delivery to Buyer F.O.B. point of manufacture. The foregoing shall be the sole obligation of Seller under this warranty with respect to equipment and other property included in this agreement. With respect to equipment, materials, parts and accessories manufactured by others, Seller's sole obligation shall be to use reasonable efforts to obtain for Buyer the full benefit of the manufacturer's warranties.

### Warranty Exclusions

Repair or replacement of misuse, improper care of storage, negligence, alteration, accident, use of incompatible supplies or lack of specified maintenance are excluded from Seller's warranty obligations.

### DISCLAIMER OF WARRANTIES

THE FOREGOING WARRANTY EXPRESSIONS ARE IN LIEU OF ALL OTHER WARRANTIES, EXPRESSED OR IMPLIED, INCLUDING IMPLIED WARRANTIES OF MERCHANTABILITY AND FITNESS FOR A PARTICULAR PURPOSE, AND EXISTENCE OF ANY SUCH OTHER WARRANTY IS HEREBY DENIED.

### Limitation of Liability and Remedies

The liability of Seller for breach of any warranty obligation hereunder is limited to:

1. The repair or replacement of the equipment on which the liability is based; or,
2. At Seller's option, the refund to Buyer of the amount paid by Buyer to Seller for said equipment.

All other liability of Seller with respect to this Agreement, or from the manufacture, installation, maintenance, repair or use of any equipment covered by or furnished under this Agreement, whether in contract or in tort, or otherwise, is limited to the amount paid by Buyer to Seller pursuant to the terms hereon:

SELLER SHALL NOT BE LIABLE FOR INCIDENTAL OR CONSEQUENTIAL DAMAGES OF ANY KIND WHATSOEVER. THE REMEDIES SET FORTH HEREIN ARE EXCLUSIVE.

### Breach

Any breach by Seller with respect to any items or unit of equipment shall be deemed a breach with respect to that item or unit only.

### Infringement

Seller will not be liable for the infringement of any patent by the Buyer's use of any equipment or materials delivered hereunder.

### POLICY REGARDING AVAILABILITY OF SERVICE PARTS

APV will attempt to remain in a position to supply replaceable service parts during the normal life of any item of APV equipment. This will be contingent upon availability of tools, material, and facilities of our own as well as of our suppliers.

After expiration of this period, supply of service parts will be limited to available stock of completed parts. If unable to supply service parts, drawings may be furnished (when available) to permit local manufacturing, if desired.

APV reserves the right to improve, change or modify the construction of its equipment or any parts thereof without incurring any obligation to provide like changes to equipment previously sold.

---

## **A Word About APV Service Parts**

---

We want to raise your awareness to the problem associated with purchase of parts not manufactured to the high quality specifications of APV.

In addition to our high quality, APV parts are manufactured to meet regulatory agency authorizations, approvals and certification (USDA and OSHA). Where applicable, materials used in construction of APV parts conform to FDA regulations.

**WARNING**

**PARTS NOT MANUFACTURED TO OUR SPECIFICATIONS MAY CAUSE DAMAGE TO YOUR APV EQUIPMENT AND VOID ALL WARRANTIES. USE OF PARTS THAT DO NOT MEET APV'S SPECIFICATIONS MAY CAUSE PROPERTY DAMAGE AND SERIOUS BODILY INJURY.**

Types of equipment include, but are not limited to, rotary pumps, centrifugal pumps, homogenizers, scrape surface heat exchangers and plate heat exchangers.

We bring this potentially serious problem to your attention in order to safeguard your best interest and those of your employees.

If you have any questions, please feel free to call 1-888-278-4321 or your local APV office.

---

## Rotor Exchange Program

---

### Obligations of Seller

Use our exchange rotor program for R Series pumps and get these benefits:

- Pump warranty protection
- 100% factory inspection of all returned rotors
- Fast turnaround direct from stock inventory
- Save up to 30% on each reusable rotor
- Save 10% on a new rotor if your return rotor is unusable
- Original equipment materials and workmanship

### Here is how the exchange program works:

1. Each new R Series pump or new service part rotor in sizes R1, R2, R3, R4, R4HD, R6, R6HD, R6SL, R700 and R700SL will be supplied with a bright green tag and an instruction sheet. (Pump assemblies will have these in the instruction manual.)
2. Should you need to exchange a rotor(s), simply place an order with your local pump distributor, or call toll free 1-888-2784321 for the location to our nearest distributor. You will be given an RFE number to mark on the green tag. If you do not have a green tag, one will be rushed to you.
3. Follow normal manual cleaning procedures before packing the rotor(s) for shipment.
4. Apply the green sticker (with your assigned number marked on it) to the outside of your shipping package.
5. Ship FREIGHT PREPAID to:  
APV  
611 Sugar Creek Road  
Delavan, WI 53115
6. Upon receipt, the rotor(s) will be inspected to ensure that the stainless steel insert (hub) meets specifications for proper pump operation. You will be contacted and informed of the condition of your returned rotor(s) and given pricing and delivery information.



And:

- a. If the insert (hub) is in usable condition, you will receive the exchange rotor price. (Up to 30% less than the cost of a new rotor.)
- b. If the insert (hub) is not reusable, you will still receive a 10% discount on the cost of a new rotor.

### Conditions:

1. Rotors Covered: R Series Rotary Pump 5-lobe rotors in sizes R0, R1, R2, R3, R4, R4HD, R6, R6HD, and R700 with stainless steel inserts (hubs), Nitrile, EPDM and HNBR (rubber) covering, recessed and flush faces (standard).
2. All rotors submitted will become the property of APV.
3. Rotors must be exchanged for rotors of the same model size.

---

## **Safety Information**

---

The following information provides specific safety information on hazardous conditions, which are inherent in the pump.

Safe installation, operation and maintenance require proper training of all personnel and their supervisors.

Our objective in providing instructions and warnings is to identify each area of potential hazard and its level of severity and to guide each worker for safe operation, service and maintenance procedures.

APV equipment is designed to provide minimum operator access to hazardous areas while providing adequate access for service by trained personnel.

Hazardous areas are provided with guards. Various types of fasteners may be used for the guards depending on how frequently routine access is required. Regardless of the type of fastener used, the mere existence of a guard should alert the worker to the presence of a hazard. Never operate or test run the equipment with a guard removed, unless under the supervision of properly trained and authorized personnel. Then use extreme caution to avoid the hazard.

### **Safety Decal Location**

The following illustrations show the typical location of the safety information decals attached to the pump. If any decal is removed or becomes unreadable, replace it immediately with a new decal.



---

## **Safety Information**

---

### **Definitions**

#### **DANGER**

An immediate hazard with a possibility of severe personal injury or death if instructions, including recommended precautions, are not followed.

#### **WARNING**

Hazards or unsafe practices which could result in severe personal injury or death if instructions, including recommended precautions, are not followed.

#### **CAUTION**

Possible hazards or unsafe practices which could result in minor injury or damage to product or property, if instructions and recommended precautions are not followed.

#### **LOCK OUT**

A positive means of securing the main electrical disconnect in the O position, where only the person involved in the maintenance procedure has possession of the key.

---

## **Safety Information**

---

### **Safety Decals**

The following decals are attached to each pump. The wording is shown below. If any decal is removed or becomes unreadable, replace immediately with a new decal. Order from APV using the part number shown.

Each pump has a tag attached when it is shipped from the factory. The wording of the tag can be read as shown below.

---

## Safety Information

---

### Electrical Hazard

The pump is normally powered by an electric motor and may have other electronic controls and devices. This creates a hazard of electrical shock, which could cause severe injury or even loss of life.

#### To minimize the risk of this hazard:

1. All electric/electronic installation must comply with all applicable codes and standards including those established by the Occupational Safety and Health Administration (OSHA) and EC Machinery Directive.
2. All electric/electronic installation, maintenance and service must be performed by trained and authorized electricians only.
3. Install a main power disconnect On-O switch that can be locked in the power O position and have the key removed. This will allow maintenance or service to be performed with no possibility of the power being accidentally turned on.
4. Thoroughly read the motor manufacturer's instructions before making installation.
5. Install an emergency shutoff switch within easy reach of the operator.
6. Make the installation suitable for a wet environment, including:
  - a. Protection from flooding. Do not install in an area which could fill with water to a level which would contact the motor
  - b. Protection of all electrical connections within a sealed junction box
  - c. Proper grounding

### Mechanical Hazard

The unit has mechanical drive components. All of these components are guarded and/or enclosed. However, it is necessary to remove the guards/enclosures to perform routine maintenance, cleaning, or service procedures. These components are powered by electric motors, which may start unexpectedly from a remote control signal. Should the unit start unexpectedly during these procedures, severe injury or even loss of life could result.

#### To minimize the risk of this hazard:

1. Only trained and authorized mechanics should perform maintenance or service work on the unit.
2. Install an emergency shutoff switch within easy reach of the operator.

---

## Safety Information

---

### **Cleaning/Sanitizing Chemical Hazard**

To properly clean and sanitize the pump for use with food products, it may be necessary to use chemical solutions. Many of the commonly used chemical solutions could cause severe injury to personnel if contacted. The hazard is especially severe for eyes, skin, or inhalation.

#### **To minimize the risk of this hazard:**

1. Thoroughly train all personnel working with cleaning/sanitizing chemicals in their safe handling and disposal following use as required by OSHA's "Hazardous Materials Standard" and EC Machinery Directive.

Additional precautions are required during the use of cleaning or sanitizing chemical solutions to minimize the risk of personnel contact which could cause an injury.

2. When using manual cleaning methods:
  - a. Turn off the power source and Lock Out before disassembling the pumps.
  - b. Equip all personnel using cleaning/sanitizing solutions with protective clothing including eye protection.
  - c. Thoroughly train all personnel using cleaning/sanitizing in their safe handling and disposal after use.
  - d. Never use toxic and/or flammable solvents for cleaning.

### **High Temperature Hazard**

When hot products are being processed, or when high temperature cleaning/sanitizing solutions are used, they create a hazard of burns.

#### **To minimize the risk of this hazard:**

1. All installation, maintenance and service of piping, valves and other controls must be performed by trained and authorized plumbers only. This applies to service media piping, process piping and cleaning / sanitizing piping.
2. All plumbing installation must comply with all applicable codes and standards including those established by OSHA and EC Machinery Directive.
3. All high temperature lines must be labeled leak free and insulated or otherwise protected from direct contact.
4. Never disconnect any lines or fittings until the line is not under pressure and the fluid inside is not hot or otherwise harmful.
5. Operating personnel must be authorized and trained.

---

## Safety Information

---

### **High Pressure Hazard**

Fluids processed by a pump are under pressure. This creates a hazard to personnel working in the area should a leak occur. Leaking high pressure fluid may cause injury by startling personnel or from actual contact with the leaking fluid.

#### **To minimize the risk of this hazard:**

1. All installation, maintenance and service of piping, valves and other controls must be performed by trained and authorized plumbers only. This applies to process piping and cleaning/sanitizing piping.
2. All plumbing installation must comply with all applicable codes and standards including those established by OSHA and EC Machinery Directive.
3. Never disconnect any lines or fittings (whether process or cleaning/sanitizing) or disassemble the pump when they are under pressure.
4. Should a leak occur, immediately find the cause and stop the leak.

### **Leaking Fluid Hazard**

Fluid leaks or spills may occur in any pumping system. This creates a hazard to personnel in the area due to slippery floor conditions or contact with possibly hazardous fluids.

#### **To minimize the risk of this hazard:**

1. Always clean up leaks and spills immediately
2. Find and correct the cause of the leak immediately

---

## Important Cautions

---

The following important cautions describe ways to avoid incorrect operating procedures which will cause serious damage to the pump.

### **Corrosion Pitting**

Stainless steel is subject to a risk of corrosion when improperly cleaned or sanitized.

#### **To minimize this risk:**

1. Never use steel wool or a wire brush to clean stainless steel surfaces. Iron particles will embed and cause corrosion pits. Use a nonmetallic brush or scrub pads for stubborn soil.
2. Never allow prolonged contact of sanitizing solutions or other corrosive cleaning chemicals with stainless steel. Use sanitizers only immediately prior to processing. Do not use sanitizers on exterior, non-product contact surfaces.

### **Motor Overload**

Depending on the rotor diameter and motor horsepower, there is a risk the pump motor will overload if operated with a partially restricted discharge.

#### **To minimize this risk of this hazard:**

Before operating the pump, review performance curve and application giving considerations to motor horsepower and pump model versus expected discharge flow rate and pressure. If the pump is operated with greater than expected discharge pressure, the load on the motor will increase.

Install a throttling type valve in the discharge piping to allow control of pump discharge flow rate during initial operation. The valve may be removed later when the system is proven to supply adequate discharge pressure to prevent overload.

### **Cavitation**

Cavitation is a condition within the pump, which results in extreme hydraulic forces which can create a risk of severe damage to pump components. Cavitation makes a characteristic “rattling” noise. It is caused by operation with too low fluid pressure at the pump inlet.

#### **To minimize this risk of this hazard:**

Install and operate the pump so that NPSH (net positive suction head) available to the pump equals or exceeds the NPSH required as shown on the pump performance curve. To increase NPSH available:

1. Decrease the temperature of the liquid being pumped.
2. Increase the height of liquid supply level.
3. Decrease the suction line length and remove restrictions to flow such as elbows, valves, etc.
4. Increase the suction line size (diameter).
5. Reduce the pump flow rate (throttle discharge).

---

## General Information

---

### Components and Services Furnished by the Customer

#### Installation

The installation and start-up of this equipment is solely the responsibility of the purchaser unless specifically provided for in the purchase agreement or in a separate contract.

#### Piping

All piping is to be supplied and installed by the purchaser. Piping must be well supported near the unit and in line with connection fittings so that no strain is put on the fittings. The use of large diameter lines and wide sweep elbows is recommended to keep discharge pressures to a minimum level.

#### Utilities

All services for water, vacuum, electricity, air and other connections needed for operation are to be provided by the purchaser.

#### Sanitary Design

The materials of construction in product contact areas are stainless steel or other materials approved for food contact. All product contact surfaces must be smooth, free-draining and accessible for cleaning. The mechanical product components must be easy to disassemble for cleaning and/or inspection for cleanliness. The outer construction must prevent outside contaminants from draining or dripping into the product area.

#### Receiving and Inspection

1. APV equipment is inspected prior to shipment. When leaving the factory, it is well crated for normal transportation procedures APV cannot, however, guarantee safe arrival. Therefore, upon receipt of this equipment, check the received items against the packing list for damage or missing parts. Check the packing material thoroughly for small parts.
2. Visually inspect for damage or loss. Damage or loss should be reported immediately to the delivery carrier while present. Following the immediate notification of the lost or damaged parts, a detailed description including quantity, description of the loss or damage, and a cash value should be claimed against the carrier with respect to the guidelines set forth by the responsible carrier's policies. APV's responsibility terminates F.O.B point of manufacture unless otherwise specified per the General Terms and Conditions of Sale as published by APV and amended from time to time. Contact APV Order Services if shipping information is required for handling claims.

---

## General Information

---

3. In the case of damage or loss to the equipment, APV may perform three major functions:
  - a. **Manufacturer Function** – APV manufactures quality equipment and stands behind the APV Standard Warranty. Refer to the Standard Warranty.
  - b. **Assessor Function** – APV offers assessment services for filing claims. The APV assessor will accurately determine the extent of the damage (or loss) and cost of repairs to the equipment. Reimbursement for this service will be agreed upon prior to the assessment.
  - c. **Repair House Function** – APV offers services for repairing the damage(s) or replacement of loss(es) to the equipment. APV has the option to alter the Standard Warranty on refurbished or replacement parts. The cost of this service will be dependent upon the assessment that is made.

### General

APV rotary pumps are known the world over for their rugged, long-lasting, efficient performance. Every pump in the line has a stainless steel body, applicable rotors and a heavy cast iron gearcase - all of which are designed to give long lasting, economical service over a wide range of products and applications.

Shown below, and throughout this manual, are typical pump sizes and design options available for almost any application.



## General Information

### Specifications

		PUMP SIZE						
		R0	R1	R2	R3&R3HD	R4&R4HD	F6&R6HD	R700
Maximum Pressure	psig	100	100	100	**	**	**	**
	bar	6.9	6.9	6.0	**	**	**	**
Maximum Capacity	US pgm	2.5	6.0	9.0	36	90	150	200
	m3/hr	0.57	1.37	2.0	8.2	20.4	34.1	45.4
Maximum Speed	rpm	600	600	600	600	600	600	400
Displacement per Revolution	in <sup>3</sup>	1.065	2.37	3.54	14.8	40.4	67.2	134.4
	cm <sup>3</sup>	17.5	39	58	234	662	1101	2202
	lb. water	0.039	0.085	0.128	0.534	1.46	2.43	4.86
	grams water	17.5	39	58	243	662	1100	2200
Inlet & Outlet Connection Size(s) Standard Body	in	1.5	1.5	1.5	1.5&2	2&3	2.5&3	4
	mm	38	38	38	38&51	51&76	64&76	102
Throat Size(s)	in	0.4x0.9	0.75	0.94	1.40&1.87	1.87&2.75	2.37&2.75	2.38&5.38
	mm	0.49x0.9	19	24	36&47	47&70	60&70	60&137
Throat Area	in <sup>2</sup>	0.326	0.442	0.69	1.54&2.75	2.75&5.94	4.41&5.94	11.55
	cm <sup>2</sup>	2.1	2.9	4.5	9.9&18	18&38	28&38	75
Optional Rectangular Inlet Size	in	N/A	N/A	.88x2.5	1.5x4.5	1.75x9.25	3x9.25	6.63x9.25
	mm	N/A	N/A	22x64	38x114	44x235	76x235	168x235
Optional Rectangular Inlet Area	in <sup>2</sup>	N/A	N/A	2.19	6.75	16.2	27.8	61.3
	cm <sup>2</sup>	N/A	N/A	14.1	43.3	103	179	395
Optional Front Cover Outlet Connection Size	in	N/A	N/A	N/A	1.5&2	3	3&4	4
	mm	N/A	N/A	N/A	38&51	76	76&102	102
Throat Size	in	N/A	N/A	N/A	1.40	2.37	2.37&2.38+	2.38+
	mm	N/A	N/A	N/A	36	60	60&61	
Throat Area	in <sup>2</sup>	N/A	N/A	N/A	1.54	4.41	4.41&5.39	5.39
	cm <sup>2</sup>	N/A	N/A	N/A	9.9	28	28&35	35
Maximum Power Requirement	BPH	0.5	0.9	1.5	4	8.5	14	20
	kw	0.37	0.67	1.12	3	6.3	10.5	15
Shipping Weight *	lbs	43	45	45	85	195	210	355
	kg	20	21	21	39	88	95	161

\* Shipping weight includes the combined weight of the pump and the shipping crate  
 \*\* Standard Pump pressure maximum is 100 psig (6.9bar),  
 Heavy-duty pump pressure maximum is 150 psig (10.35 bar)

#### CONVERSION FACTORS

Quantity	English Unit	SI Unit	Parameter	English Unit	SI Unit	Parameter	English Unit	SI Unit
Length	1 ft	3048 meter	Volume	1 in <sup>3</sup>	15.39 cubic cent	Pressure	1 in of water	
Force	1 lb	4.448 newtons		1 ft <sup>3</sup>	.0283 cubic meter		039.2 °F	249.1 pascals
Pressure	1 lb/in <sup>2</sup>	6895 pascals	Velocity	1 ft/sec	30.48 cent/sec.		1 lb force /	
Temp.	*F=1.8°C+32	*C=(°F-32)/1.8		1 ft/sec	.3048 meters/sec		sq in (psi)	6.894 kilopascals
Absolute Temp.	Rankine (*R)	Kelvin (*K)	Volumetric Flow Rate*	1 in <sup>3</sup> /sec	15.39 cubic cent/sec	Energy	1 ft-lb	1.356 joules
Temp.	*R=*F+460	*K=*C+273		1 in <sup>3</sup> /min	2731 cubic cent/sec	Force	1 lb	4448 newtons
	*R=1.8*K	*K=*R/1.8		1 ft <sup>3</sup> /sec	28.32 liters/sec	Torque	1 lb force-in	1130 newton-met
Energy	1 ft-lb	1.356 joules		1 ft <sup>3</sup> /min	1599 liters/sec		1 lb force-ft	1356 newton-met
Power	1 ft-lb/sec	1.356 watts		1 gal/sec	3.785 liters/sec	Absolute Viscosity**	1 lb	
	1 hp	7457 kilowatts		1 gal/min	.0631 liters/sec		force-sec/foot <sup>3</sup>	47.88 pascals/sec
				1 gal/min	.2271 m <sup>3</sup> /hour			
Parameter	English Unit	SI Unit	Mass	1 lb	453.6 grams	Kinematic Viscosity***	1 ft <sup>2</sup> /sec	.0929 meter <sup>2</sup> /sec
Length	1 in	2.540 cent		1 lb	4536 kilogram			
	1 ft	3048 meter	Pressure	1 standard atmosphere				
	1 mile	1.809 kilometers		(14.7 psi)	101.3 kilopascals			
Area	1 in <sup>2</sup>	6.452 sq cent						
	1 ft <sup>2</sup>	.0929 sq meter						

\*1000 liters = 1 cubic meter  
 \*\* 1 pascal = second = 10 poise  
 \*\*\* 1 square meter/sec = 10,000 strokes

## General Information

### Available Design Features

	BASIC PUMP SIZE									
	0	R1	R2	R3	R3HD	R4	R4HD	R6	R6HD	R700
<b>GEARCASE MOUNTING</b>										
Standard Base Mount	x	x	x	x	x	x	x	x	x	x
Top Feed with Right Angle Bracket	x	x	x	x	x					
Top Feed with Pedestal						x	x	x	x	x
Top Feed, Ceiling Mount (RI & FCO Only)						x	x	x	x	x
Top Feed, Floor Mount (RI & FCO Only)				x	x	x	x	x	x	x
"B" Side Mount, Rectangular Inlet						x	x	x	x	x
<b>GEARCASE SHAFT (Coupling End)</b>										
Size - Standard (inches) Shaft Diameter	0.75	0.75	0.75	1	1	1.375	2.25	1.375	2.25	2.25
Location – Top or Bottom (Std. Mount)	x	x	x	x	x	x	x	x	x	x
Location – Right or Left (Top Feed)	x	x	x	x	x	x	x	x	x	x
Vented Cover (Internal By-pass)		x	x	x		x		x		
Water Flush Seals		x	x	x	x	x	x	x	x	x
Rectangular Inlet			x	x	x	x	x	x	x	x
Degasser / Deaerator				x	x	x	x	x	x	x
Front Cover Outlet (RI Pumps Only)				x	x	x	x	x	x	x
Full Flow By-pass Cover				x		x		x		
<b>ROTORS</b>										
Number Lobes – Standard	2	5	5	5	5	5	5	5	5	5
Number Lobes – Optional								1	1	1
Recessed Face		x	x	x	x	x	x	x	x	x
Flush Face	x		x	x	x	x	x	x	x	x
Stainless Steel Hub Rubber Covered	x	x	x	x	x	x	x	x	x	x
Plastic Hub Rubber Covered	x	x	x	x	x	x	x	x	x	x
Optional Solid Plastic (Reinforced Epoxy)			x	x	x	x	x	x	x	X
Optional Celcon Covered		x	x	x	x					
Optional Solid Metal Nitronic 60 / NG = Non-Gall)			NG	NG		NG		NG		NG
Cover Wing Nuts	x	x	x	x	x	x		x		

RI = Rectangular Inlet  
FCO = Front Cover Outlet

---

## General Information

---

### Special Pump Types

#### **R1, R2, R3, R4 and R6 Pumps with Vented Cover**

Vented cover pumps are designed for use where a pressure release device is needed or where variable back pressures interfere with regulated flow. The vented cover protects the system against excessive pumping pressures. It is available for either manual or air (pneumatic) operation.

The vented cover is not available on the heavy-duty rotary pumps or front cover outlet pumps.

#### **Heavy-Duty Pumps**

Heavy-duty pumps are available in R3, R4, R6 and R700 models. They are designed for applications where long discharge lines and/or viscous products combine to create high head pressures. These pumps are equipped with external outboard bearings to prevent shaft deflections and minimize shaft, rotor and seal wear. Heavy-duty pumps are recommended for discharge pressures between 100 and 150 PSIG (7 and 11 kg/cm<sup>2</sup>).

#### **Front Outlet Cover Pumps**

The front outlet cover (available on rectangular inlet pumps in sizes R2, R3, R3HD, R4, R4HD, R6, R6HD and R700) enables lowest possible pump installation next to floor. This is important for hopper pumps which must receive product from low dump heights. Viscous and/or high pressure applications may cause excessive rotor/body wear. Contact an APV office for consultation.

#### **Round Inlet Top Feed Pump**

The top feed pump (available in all sizes) has been designed to pump the more viscous and difficult to move products. A direct vertical downward entrance to the pump is the main factor in the success of this pump in handling such products.

#### **Rectangular Inlet Top Feed Pump**

The rectangular inlet top feed pump (available in R2, R3, R4, R6 and R700 sizes) has been designed to supplement the top feed pump and the handling of difficult to move product. The large inlet assures entrance into the pump of a wide variety of products usually considered impossible to pump and also minimizes objectionable air inclusion in the product.

---

## General Information

---

### **Rotors**

APV offers several basic types of rotors for use in rotary pumps. The standard type has a stainless steel hub and rubber covering. Optional types are: epoxy hub rubber covered, solid epoxy, celcon with stainless steel hub, and solid non-galling metal rotors. Additional options are available within the various basic model types – options such as face configuration and undersize for high temperature operation.

### **Rotor Identification**

The basic rotor types are easy to identify from the descriptions that follow. Various codes may appear on the rotor hub. One four digit code (for example: 1025) identifies whether the rotor is undersize for high temperature operation.

Solid Epoxy hub rubber covered rotors have a letter etched into the hub area to designate the rubber covering material. “N” for example, designates Nitrile rubber.

In addition, stainless steel hub rubber covered rotors have a manufacturing code (for factory identification purposes) consisting of a single digit, followed by a letter (month), then three more digits (day & year). A similar code is used for plastic hub rotors.

### **Stainless Steel Hub-Rubber Covered**

This is the standard rotor. The long time standard rotor design is a stainless steel hub with a Nitrile rubber covering. This rotor is available with the normal recessed face or with a flush face and as undersized rotors for high temperature operation. We also have oversize available for low temperatures. All rotors, except the R0 size, have 5 lobes; the R0 size has 2 lobes and an optional 5 lobe design. An optional single lobe rotor is available for R6 and R700 size pumps.

### **Standard Recessed Face & Flush Face**

The standard rotor configuration is the recessed face. The recessed face has the least amount of rubber surface contacting the pump cover and body, therefore, the least friction/wear in this area. In addition, the recessed area admits product into the rotor face area. Product in the recess area may further lubricate the rotors, especially if the product does not contain fats or oils.

Flush face rotors exclude product, as far as possible, from the rotor face area. This reduces friction/wear when product is abrasive or contains abrasive particles such as berry seeds (flush face rotors are recommended for these applications). Flush face rotors are also required with the degassing/deaerating front cover outlet pumps.

---

## General Information

---

### Undersize Rotors

Undersize rotors are available to accommodate operation at elevated temperatures. The materials of the rotor expand with increasing temperature. Undersize rotors enable operation without excessive interference between rotor and pump body. A coding system is used to identify undersize rotors. The four digit code number is stamped into the hub (stainless steel hub) or etched (plastic hub). The first two digits indicate the amount of undersize on the width dimension. The second two digits similarly indicate the undersize dimension on the diameter. For example: 1025 undersize is 0.010 in. less on width and 0.025 in. less in diameter. The letters “TH” indicate the entire rotor profile is undersize in addition to the width and diameter. Full size rotors have no identification on the hub.

The following data lists the maximum recommended operating temperature for the various size rotors. For best pumping efficiency, select the size which most closely matches product temperature. Applications with extreme viscosity and extreme pressure (e.g., ground cheese for processed cheese system) should use TH undersize rotors, even with product temperature much below the rating. The extra clearance compensates for shaft deflection under the high pressures. For applications with more than one temperature product, select rotor size based on the highest temperature. Increase pump speed at the lower temperature to compensate for the extra rotor clearance.

Stainless steel hub rotors have a different recommended maximum temperature than plastic hub rotors due to a different rate of thermal expansion.

Rotor Size Code	Maximum Recommended Temperature	
	Stainless Steel Hub	Plastic Hub
Over Size + 0510	Under 100 F	
Full Size	100 - 150 F	Up to 150 F (66 C)
0510	150 - 200 F	Up to 200 F (93 C)
1025	200 - 250 F	Up to 250 F (121 C)
1540	250 F	HNBR Material Only

Oversized rotors are available for specific applications only. Contact an APV office for consultation.

### Epoxy Hub-Rubber Covered Rotors

Available in select sizes ONLY.

The epoxy hub gives the following advantages over stainless steel hubs.

- Lighter in weight
- Less wear to the pump shaft
- Non-metallic, non-sparking construction

---

## General Information

---

The reinforced epoxy hub material is not as strong as stainless steel hubs. Therefore, it is recommended they not be used for extreme viscosity applications such as those requiring auger feed pumps, or for pressures over 100 psi (7.0 kg/cm<sup>2</sup>).

The following information details the construction and application limitations of plastic hub rotors.

### Construction

**Hub** – The Hub is CREPAKYLAN 461 Fiberglass reinforced epoxy. This material is very strong and wear resistant. It meets all requirements of FDA, USDA, 3-A and BISSC for materials in contact with food products.

**Covering** – The Nitrile rubber covering formula used for plastic hub rotors is the same as the current standard stainless steel hub rotors. Excellent bonding between hub and rubber is also achieved. Better dimensional integrity is assured due to more uniform rate of thermal expansion between hub and rotor.

The epoxy formula meets all requirements of FDA, USDA, 3-A and BISSC for materials in contact with food products. The appearance is less shiny than previous Nitrile covered stainless steel hub rotors.

**Alternate Covering Materials** – The plastic hub can also be coated with covering materials. Contact an APV office for further details.

### Application Recommendations

**Pressure:** Recommended for up to 100 psi (7.0 kg/cm<sup>2</sup>)

**Temperature:** Recommended for product temperatures up to 250 F (121 C maximum)

### Solid Epoxy Rotors

**Material** – the solid epoxy rotor is made entirely from CREPAKYLAN 461 Fiberglass reinforced epoxy. This material is very strong and wear resistant. It meets all requirements of FDA, USDA, 3-A and BISSC for materials in contact with food products. The following list shows typical chemical compatibility of this material.

---

## General Information

---

### Rotor Clearance

Out of necessity, the solid epoxy rotors have greater clearances than rubber covered rotors. Therefore, they have more slip (pumping inefficiency) and higher speed (rpm) is required to compensate. The effect is greatest when pumping low viscosity water like fluids and when high discharge pressures are required. For such applications, stainless steel or epoxy hub rubber covered rotors should always be the first choice. If there is no alternative but solid epoxy rotors, then select a pump size which would normally operate 150 rpm more based on standard performance curves. Then select a drive with speed capability two to three times that indicated. Applications with medium to high viscosity products and lower discharge pressures are more readily accommodated by solid epoxy rotors with less drastic speed compensation.

### Temperature

Experience has shown that maximum temperature for successful operation with solid epoxy rotors is 220 F (104 C). The material of the rotor is not adversely affected by the heat and can withstand much higher temperatures. However, the expansion due to heat may cause severe rotor binding and rotor damage at excessive temperatures. Undersize solid epoxy rotors for high temperature operation are not practical at this time.

### Pressure

The maximum recommended differential pressure when using solid epoxy rotors is 100 psi (7.0 kg/cm<sup>2</sup>). This recommendation is due in part to the inefficiency mentioned in the "Rotor Clearance" section.

Another factor is that shaft-rotor hub wear becomes more critical at higher operating pressures. As the shafts and rotor hubs wear, eventually rotor to rotor contact will occur. At high operating pressure, this contact could cause rotor damage. See shaft wear limitation data which follows.

Following is a list of products and applications successfully using solid epoxy rotors as reported by our sales force.

Product	Temperature		Pressure	
	F	C	psig	kg/cm <sup>2</sup>
Aloe Gel with Gum	110	43	20	1.4
Aloe Vera Lotion	110	43	20	1.4
Cake Icing	60-110	16-43	30-50	2.1-3.5
Cheese Spread	170	77	*	*
Cheese (Processed)	75-190	24-88	40	2.8
Corn Syrup, High Fructose	70-120	21-49	45	3.2
Fish Meal	160	71	*	*
Fruit Puree	50	10	*	*
Gum Slurry	*	*	*	*
Poultry Digest	80-120	27-49	*	*
Pretzel	112	44	50	3.5
Shaving Cream	110	43	20	1.4

\*Proprietary Information

---

## General Information

---

Certain products have demonstrated that they cannot be pumped successfully using solid epoxy rotors. One such is tomato base products, such as spaghetti sauce, pizza sauce, tomato juice or tomato soup. Tomato base products cause an excessive rate of wear, especially at higher temperatures.

Another troublesome product group is extreme viscosity non-uid products such as commonly handled by auger feed pumps. In part, the problem here is the very high discharge pressures normally encountered. In addition these type of products tend to resist flowing out of the area where the rotors are meshing together causing interference and rotor damage results. Products in this category include ground meat, ground cheese and dry dough preparations such as; pie dough, masa dough and rotary cut cooked dough.

### Chemical Compatibility

CREPAKYLAN 461 (solid epoxy) has good chemical resistance and is fully resistant to most common food related products, cleaning agents and sanitizers. It is also resistant to most industrial chemicals. An exception is certain strong solvents which attack the material. These strong solvents are by nature very low viscosity and therefore, in the pure state, better suited for centrifugal pumps. Potential misapplication is most likely to occur when these solvents are a significant percentage of other more viscous products requiring a positive type pump.

Following is a partial list of compatible (C) and not recommended (NR) chemicals for use with CREPAKYLAN 461 material:

Acetic Acid, 50/0, 100 F	C	Hydrogen Peroxide, 0-3%, 150 F	C
Acetone, 0-5%, 150 F	NR	Lauric Acid, 200 F	C
Acetone, 5-100%	C	Linseed Oil, 210 F	C
Alcohols, 150 F	C	Maleic Acid, 150 F	C
Beer, 210 F	C	Malice Acid, 150 F	C
Benzene, 100 F	C	Methanol 0-10%, 150 F	C
Benzoic Acid, 200 F	C	Methyl Ethyl Ketone, 75 F	C
Benzyl Chloride	C	Mineral Oil, 210 F	C
Boric Acid, 210 F	NR	Oleic Acid, 200 F	C
Brine, 210 F	C	Phenol, 150 F	C
Butadiene, 100 F	C	Phosphoric Acid, 75-100%	NR
Calcium Chloride, 10 F	C	Potassium Hydroxide, 0-45%, 210 F	C
Carbon Disulfide	C	Potassium Nitrate, 210 F	C
Carbon Tetrachloride, 100 F	NR	Propylene Dichloride	NR
Castor Oil, 200 F	C	Soap, 210 F	C
Citric Acid, 210 F	C	Sodium Carbonate, 210 F	C
Coconut Oil, 180	C	Sodium Hydroxide, 0-50%, 210 F	C
Corn Oil, 210 F	C	Sodium Nitrate, 210 F	C
Detergents Organic, 150 F	C	Sodium Peroxide, 75 F	C
Detergents – Sulfonated, 210 F	C	Sodium Silicate, 150 F	C
Ethyl Acetate, 150 F	C	Stearic Acid, 150 F	C
Ethylene Amine	C	Sulfuric Acid, 0-50%, 100 F	C
Ethylene Glycol, 210 F	NR	Tannic Acid, 200 F	C
Fatty Acids Esters, 180 F	C	Tartaric Acid, 210 F	C
Fatty Acids, 210 F	C	Toluene, 100%, 150 F	C
Formaldehyde, 0-40%, 200 F	C	Trichloroethylene, 100%, 150 F	C
Formic Acid, 0-25%, 100 F	C	Tung Oil, 200 F	C
Furfural, 70 F	C	Urea, 150 F	C
Glucose, 210 F	C	Vinegar, 150 F	C
Glycerin, 210 F	C	Vinyl Acetate, 150 F	C
Heptane, 150 F	C	Water - Distilled, 210 F	C
Hexane, 75 F	C	Water - Sea, 210 F	C
Hydrochloric Acid, 0-10%, 180 F	C	Xylene, 150 F	C



---

## General Information

---

### Celcon Rotors

Celcon rotors are available for pump model sizes R1, R2 and R3. They are available with a 316 SS hub and all have flush face configuration. They are available in “normal” size for up to 135 F (57 C) service and 05 10 undersize for up to 180 F (82 C) service.

**Material** – Celcon is a registered trademark of the Celanese Corporations. It is an acetal copolymer thermoplastic which is stable in a wide variety of chemicals. It is a white, translucent plastic material which is approved for use in contact with food products by 3-A, FDA and USDA. Celcon is a natural bearing material, having a very low coefficient of friction against metals. It also has excellent abrasion resistance, good toughness and excellent retention of mechanical properties in various environments. The accompanying information lists chemical compatibility and physical properties.

**Application** – Due to the rigid nature of this material, there is more clearance than with standard rubber covered rotors. However, there is less than with solid epoxy or solid metal rotors. Pump speed must be compensated for slip (as described for solid epoxy rotors), but to a lesser degree. The maximum recommended differential pressure for Celcon rotors is 100 psi (7.0 kg/cm<sup>2</sup>)

**Chemical Resistance.** Celcon rotors are generally recommended for the following applications:

- long term hot water exposure
- solvents (acetone & alcohols)
- petroleum oils
- strong alkalis (caustic)

They are **not recommended** for the following applications.

- strong mineral acids (sulphuric, nitric, hydrochloric)
- strong oxidizing agents (hypochlorites)

## General Information

Specific Products		Specific Products	
Acetic Acid – 10%	B	Oleic Acid	NR
Acetone	B	Oxalic Acid	NR
Alcohols	A	Paraffin	A
Brine	A	Perchloroethylene	A
Carbon Tetrachloride	A	Petroleum Jelly	A
Caustic	A	Phenol	NR
Citric Acid to 100%	A	Phosphoric Acid – to 3%	B
Detergents to 180 F	A	Potassium Permanganate – 10%	A
Edible Oils	A	Soap	A
Ethyl Alcohol – 96%	A	Sodium Hydroxide	
Ethyl Acetate	A	12 to 73 F	A
Ethylene Glycol – 50%	B	6 to 180 F	A
Formic Acid	NR	Sodium Bicarbonate – 50%	A
Grease	A	Sodium Chloride to 90%	A
Hexane	A	Sodium Hypochlorite	NR
Hypochlorites – 100%	NR	Sulfuric Acid	NR
Hydrochloric Acid – above 2%	NR	Toluene	A
Isopropyl Alcohol	A	Trichloroethylene	B
Hydrogen Peroxide	A	Vaseline	A
Lactic Acid – 10%	B	Vegetable Oils	A
Magnesium Hydroxide – 10%	A	Vinegar	B
Methyl Acetate	B	Water	A
Methyl Ethyl Ketone	B	Wax	A
Milk	A		
Nitric Acid	NR		

**A = Recommended, no change in properties**

**B = Recommended, slight discoloration**

**NR = Not recommended**

**Shaft Wear** : An important limitation of solid epoxy or plastic hub rotors is that they not be used in pumps with excess shaft wear. The following illustration and data gives wear limitations for use of these rotors.

Pump Size	Dim. A		Dim. B	
	in.	mm	in.	mm
R1, R2	0.824	20.9	¼	6
R2.5, R3	0.996	25.3	¼	6
R4, R6, R700	1.745	44.3	3/8	10

When checking for shaft wear, measure no further in than the B dimension. If there is wear, it will be near the corners of the shaft.

---

## General Information

---

### Minimum Shaft Wear

Physical Properties of Celcon:

Property	ASTM Test Method	Units	Temp.	Value
Specific Gravity	D792	--	73	1,410
Tensile Strength	D638	psi	73	8,800
Elongation	D638	%	73	60.
Tensile Modulus	D638	psi	--	410,000
Flexural Modulus	D790	psi	73	375,000
Flexural Stress (5% Deformation)	D790	psi	--	13,000
Compressive Stress	D695	psi	--	4,500
Izod Notched (Impact Strength)	D256	ft lb/in	73	1.3
Water Absorption (24 Hour Immersion)	D570	%	73	0.22
Coefficient of Dynamic Friction vs. Steel vs. Celcon	D1894	--	--	0.15 0.35

### Solid SS Metal Rotors

**Material** – The material of the solid metal rotor is a non-galling sanitary SS alloy. Solid metal SS rotors are available for the R2, R3, R4 and R6 is non-galling alloy stainless steel. Wear rings are required for the faces of solid metal rotors to keep them from contacting the pump cover or body during operation. Standard materials for wear rings are a PPS (Ryton) material and a Teflon material which are approved for food product applications. Non-galling SS wear rings for more aggressive duties are also available.

**Rotor Clearance** – As with the solid epoxy rotors, the solid metal rotors have greater clearances than rubber covered rotors. Consequently, their use is primarily intended for products with substantial viscosity. If low viscosity, water like products is pumped, higher rpm will be required to compensate, or discharge pressure will be limited.

**Torque Limited Drives** – Some type of torque limiting drive or drive coupling is recommended when using solid metal rotors. Should a solid piece of foreign metal pass through the pump, it could jam between the rotors. A correctly sized torque limiting device will protect the pump shafts from damage in the event of a jam.

### Rotor Pullers

Several rotor puller tools are available for the various sizes and types of rotors. These tools are illustrated in the Service Parts section of this manual.

A pliers type and a three prong type is available for sizes R0 through R3 rubber or Celcon covered rotors. These pullers grip the outside contour of the rotor.

A locking pliers type with soft covered jaws is available for solid plastic rotors. This type is available for R3 through R6 sizes. This puller also grips the outside contour of the rotor.

---

## General Information

---

A special 4-way (star) wrench is available for R3 through R6 sizes. One end of this puller engages grooves machined inside the square hole of stainless steel hub rotor (this puller will not work with heavy-duty model pumps).

A heavy-duty puller tool is available for R4 through R700 size pumps. This tool also engages a groove machined into the square hole of stainless steel hub rotors or solid metal rotors. These grooves are different from the grooves for the 4-way wrench mentioned above. The heavy-duty puller is the only tool which may be used with R4HD, R6HD or R700 size pumps. This puller is recommended when product conditions make rotor removal difficult with the 4-way puller tool. These rotors have the heavy-duty grooves on one side and the grooves for the 4-way wrench on the other. Care must be used when assembling these rotors so that the correct groove is located toward the pump cover.

Rotor Pullers	Part No.	Use with Rotor Type
RO size (pliers type)	M03A-P-367535	SS hub rubber covered
R1 or R2 (3-prong type)	M03A-P-188155	SS hub rubber or Celcon covered or plastic hub rubber
R2.5 or R3 (3-prong type)	M03A-P-225667	SS hub rubber or Celcon covered or plastic hub rubber covered
R3 (locking pliers type)	M03A-P-395466	solid plastic
R3 (special 4-way wrench)	M03H-P-133586	SS. hub rubber or Celcon covered
R4 or R6 (locking pliers type)	M03A-P-385820	plastic hub rubber covered or solid plastic
R4 or R6 (special 4-way wrench)	M03H-P-133613	SS. hub rubber covered
R4HD or R6HD (heavy-duty puller)	M03A-P-250898	heavy-duty SS hub rubber covered or solid metal
R700 (heavy-duty puller)	M03A-P-221079	heavy-duty SS. hub rubber covered or solid metal

---

## General Information

---

### Clearance for Particulates

The following data gives dimensions critical to the pumping of particulates through rotary pumps. The maximum recommended particulate size in either a spherical or cube shape is also listed.

**This does not mean that all particulates under the size limit may be successfully pumped without damage to the particulate or the pump. Other factors which must be considered are:**

- Particulates must be in suspension. The carrier liquid must prevent the particulates from sticking together and disturbing the pumping performance.
- The carrier liquid must have sufficient viscosity to keep the particulates moving into the pump inlet. For example, whole kernel corn in water will not pump, as the corn bridges at the inlet and the water is pumped away.
- Use a top feed, rectangular pump whenever possible.
- As a general rule, use a large pump with a large inlet size to enable a relatively slow pump speed.
- Avoid very hard particulates which could wedge between rotor lobes and cause rotor damage.

Pump Model	A (Pocket)	B (Rotor Width)	C (Inlet/Outlet)	Maximum Particle	
				Sphere Diameter	Cube Size
R0	0.206 in.	0.787 in.	0.40 in.	3/16 in.	3/32 in.
	0.511 in.	0.558 in.	0.37 in.	11/32 in.	3/16 in.
	0.511 in.	0.836 in.	0.44 in.	7/16 in.	¼ in.
	0.667 in.	1.001 in.	0.48 in.	15/32 in.	¼ in.
	0.667 in.	2.001 in.	1.378 in.	21/32 in.	3/8 in.
R1	0.511 in.	0.558 in.	0.750 in.	½ in.	9/32 in.
R2	0.511 in.	0.836 in.	0.937 in.	½ in.	9/32 in.
R3	0.667 in.	2.005 in.	1.402/1.870	21/32 in.	3/8 in.
R4	1.000 in.	2.405 in.	1.870/2.750	1 in.	9/16 in.
R6	1.000 in.	4.005 in.	2.370/2.750	1 in.	9/16 in.
R700	1.000 in.	8.005 in.	2.375 in.	1 in.	9/16 in.
R0	5.23 mm	20.0 mm	10.2 mm	5 mm	3 mm
	13.0 mm	14.2 mm	9.4 mm	9 mm	5 mm
	13.0 mm	21.2 mm	11.1 mm	11 mm	6 mm
	17.0 mm	25.4 mm	12.3 mm	12 mm	7 mm
	17.0 mm	50.8 mm	35.0 mm	17 mm	10 mm
R1	13.0 mm	14.2 mm	19.1 mm	13 mm	7 mm
R2	13.0 mm	21.2 mm	23.8 mm	13 mm	7 mm
R3	17.0 mm	50.9 mm	35.6/47.5	17 mm	10 mm
R4	25.4 mm	61.1 mm	47.5/69.9	25 mm	14 mm
R6	25.4 mm	101.7 mm	60.2/69.9	25 mm	14 mm
R700	25.4 mm	203.3 mm	60.3 mm	25 mm	14 mm

## General Information

### Pump Shaft Seal Identification

Pump No.	Color Code	Pressure Vacuum Seal (100 psig max.)	Pressure Seal (150 psig max.) *	Pressure Vacuum Heavy-Duty
R0	Blue	M03H-P-331053	N/A	
	Red	M03H-P-331053	N/A	
	Two Orange	M03H-P-331053	N/A	
R1, R2	Green	M03H-P-151261	M03H-P-171623	N/A
	Blue	M03H-P-203251	M03H-P-203261	N/A
	Red	M03H-P-203252	M03H-P-203262	M03HP411845
	Two Orange	M03H-P-203253	M03H-P-203263	M03HP411046
R3	Green	M03H-P-149531	M03H-P-203460	N/A
	Blue	M03H-P-203231	M03H-P-203241	N/A
	Red	M03H-P-203232	M03H-P-203242	M03HP411050
	Two Orange	M03H-P-203233	M03H-P-203243	M03HP411051
R4, R6 & R700	Green	M03H-P-149370	M03H-P-171624	N/A
	Blue	M03H-P-203211	M03H-P-203221	M03HP411057
	Red	M03H-P-203212	M03H-P-203222	M03HP411055
	Two Orange	M03H-P-203213	M03H-P-203223	M03HP411056

\*Not to be used in a vacuum condition.

#### Recommended Compound Usage Of:

1. Red Dot Code – Nitrile (Buna-N) – Furnished as standard for all applications or when product is highly corrosive.  
Temperature range: -40 to 250 F (-40 to 121 C).
2. Two Orange Dots Code – EPDM (Ethylene-Propylene) – For beverage syrups, especially diet types and any product containing acetic acid (vinegar). Use with steam and hot water.  
Temperature range: -40 to 300 F (-40 to 149 C).
3. Blue Dot Code – Fluorocarbon (Viton\*) – For highly corrosive products:  
Temperature range: 0 to 350 F (-18 to 177 C).
4. Green Dot Code – (Neoprene) – For use with low aniline point oils and certain other products where red dot seals prove unsatisfactory.  
Temperature range: -50 to 250 F (-46 to 121 C).

\*Viton and Neoprene are registered trademarks of  
E. I. DuPont DeNemours & Company

---

## **Installation**

---

### **Selecting Unit Location**

When installing the unit, consider these items before locating:

1. Install the unit in a location with good lighting and clearance around it for maintenance and operation.
2. Locate with consideration for required service connections. Keep service supply lines as short and direct as possible for optimum operating efficiency.
3. Locate close to associated process equipment to minimize piping between equipment and minimize pressure build up through lines. Make sure the piping to and from the pump is correctly arranged and properly supported so that there will be no unnecessary strain on pump parts.
4. Locate near floor drains with a hose station nearby.

### **Gearcase Oil**

**Refer to the Maintenance Section for recommended amount and type of oil.**

### **Rotation Check**

The rotary pump can be operated in either direction as determined by the desired inlet and discharge locations. Discharge will be on the right when the top rotor turns clockwise and on the left when it turns counterclockwise.

Disassemble pump before checking rotation. The two seal pressure relief grooves, one in the upper pump cover and one in the pump body, must always be on the discharge side of the pump. The side of the pump body is clearly stamped "IN" to help determine their correct positions.

An oversized stud hole and special large hex stud allow for mounting of the pump body and pump cover in the correct position every time.

Unless otherwise specified, the pump will always come with the hex shaped stud in the upper left hand position, looking at the front of the pump. Discharge must be taken on the right. If discharge on the left is desired, the hex stud must be interchanged with the corresponding lower right hand stud. Studs are most effectively gripped for removal and installation by tightening two nuts together on the outer thread or by using a wrench on the hex.

---

## **Installation**

---

### **Drive Unit Recommendations**

1. The Versatility and expanded use of APV pumps utilizes a variety of drives for these pumps. There are many drive units available such as multi-speed, hydraulic and air motor, V-belt and torque limited. Consult your APV representative for type and availability of desired drive.
2. When installing pumps with any of these drive units, it is most important that proper alignment be maintained between the shaft of the driven pump and the driving unit. This is absolutely necessary to achieve optimum pump performance and maximum service life.

**When installing the V-belt sheaves and chain sprockets on the shafts, always install them as close to the gearbox as possible.**

### **Torque Limited Drives**

Use of a torque limited drive or drive coupling is recommended when using solid plastic or solid metal rotors. If a solid piece of foreign material passes through the pump, it could jam between the rotors and cause extensive damage. A correctly sized torque limiting device will protect the pump shafts from damage in the event of a jam.



---

## Cleaning and Sanitizing

---

### Initial Cleaning

Prior to using any rotary pump for the first time, disassemble and hand clean the pump. Clean all inner and outer surfaces to remove any dirt, grit or film that may have accumulated during shipment and installation.

### Cleaning Tips

1. Do Not use carbon steel wool. Particles may break off and become embedded, causing rust development.
2. Do Not use water high in iron, salt or sulfur. Use distilled water if possible.
3. Do Not allow cleaners or bactericides to remain on surface for over 15 minutes.
4. Rinse all parts and surfaces exposed to corrosive cleaning solutions completely with cold water.
5. Do Not allow tools or other metal items to lie on wet stainless steel.
6. Only use recommended cleaners. Alkaline dairy cleaners or bactericides should contain a wetting agent and polyphosphate to suit water hardness.
7. If rust or discoloration occurs, polish the affected area immediately to prevent the condition from progressing. This can be done in most cases by using a damp cloth and a commercial scouring powder.

### Daily Procedure for R0 Pump

1. Place a rubber mat under the immediate area of the pump to protect parts which may drop accidentally.
2. Remove the four hex nuts, cover and O-ring from the pump body.
3. Remove the two rotors from the pump shafts.
4. Install the O-ring, cover and the four hex nuts on the pump body. Tighten the hex nuts. Do Not over tighten.
5. Rinse the outer areas of the pump and gearcase (hand clean if necessary), according to standard plant procedure. For CIP cleaning, add sufficient cleaner to maintain a 1% causticity for the duration of the cleaning cycle. Do Not leave the rotors in the pump while cleaning the system.
6. When CIP of the system is completed, remove the four hex nuts, cover and O-ring from the pump body. Inspect the O-ring and replace if necessary.
7. Remove the pump body, O-ring and back plate from the gearcase. Inspect the O-ring and replace if necessary.
8. Remove the two shaft seals from the back plate. Inspect the shaft seals and replace if necessary.
9. Remove the two seal bearings and O-rings. Inspect the O-rings and replace if necessary.
10. While the pump is disassembled, check the gearcase roller bearings for adjustment.

---

## Cleaning and Sanitizing

---

11. Clean all parts by hand using a general purpose alkaline solution at no greater than 1-1/2% caustic at a temperature of 110-120 F (45-50 C). To remove films of water stone, use an acid cleaner.
12. When cleaning is completed, dry all parts thoroughly.
13. Apply sanitary lubricant to the O-rings and install on the shafts.
14. Install the two seal bearings on the shafts and slip the O-rings over the seal bearings.
15. Install the two shaft seals in the back plate. Install the back plate on the gearcase.
16. Install the O-ring and pump body on the back plate.
17. Install the two rotors on the shafts.
18. Install the O-ring or gasket cover and four hex nuts on the pump body. Tighten the hex nuts. Do Not over tighten.

### Daily Procedure for Standard, R1, R2, R3, R3HD, R4, R4HD, R6 and R6HD Pumps

1. Place a rubber mat under the immediate area of the pump to protect the parts which may drop accidentally.
2. **R1, R2, R3 and R3HD Pumps Only.** Remove the four hex nuts, cover and gasket from the pump body.
3. **R4, R4HD, R6 and R6HD Pumps Only.** Remove the eight hex nuts, cover and gasket from the pump body.
4. Remove the two rotors from the pump shafts.
5. **R1, R2, R3 and R3HD Pumps Only.** Install the gasket, cover and four hex nuts on the pump body. Tighten the hex nuts. Do Not over tighten.
6. **R4, R4HD, R6 and R6HD Pumps Only.** Install the gasket, cover and eight hex nuts on the pump body. Tighten the hex nuts. Do Not over tighten.
7. Rinse outer areas of the pump and gearcase (hand clean if necessary) according to standard plant procedure. For CIP cleaning, add sufficient cleaner to maintain a 1% causticity for the duration of the cleaning cycle. Do not leave the rotors in the pump while cleaning the system.
8. **R1, R2, R3 and R3HD Pumps Only.** When CIP of the system is completed, remove the four hex nuts, cover and gasket from the pump body. Discard the used gasket and replace.
9. **R4, R4HD, R6 and R6HD Pumps Only.** When CIP of the system is completed, remove the eight hex nuts, cover and gasket from the pump body. Discard and replace the gasket.
10. **Rectangular Inlet (RI) Pumps Only.** Loosen the two hex head cap screws located on the sides of the pump body.
11. Remove the pump body, two shaft seals, two bearing seals, two O-rings and two seal rings from the gearcase. Inspect parts and replace if necessary.  
Standard R1, R2, R3, R3HD, R4, R4HD, R6 and R6HD Pump.

---

## Cleaning and Sanitizing

---

12. While the pump is disassembled, check the gearcase roller bearings for adjustment.
13. Clean all parts by hand using a general purpose alkaline solution at no greater than 1-1/2% caustic at a temperature of 110-120 F (45-50 C). To remove lime of water stone or milk stone, use an acid cleaner.
14. When cleaning is completed, dry all parts thoroughly.
15. Install two of the O-rings on the shafts and slip over the seal bearings.
16. Install the two seal rings and shaft seals on the body.
17. Apply sanitary lubricant to the O-rings and install on the shafts.
18. **Rectangular Inlet (RI) Pumps Only.** Prior to installing the pump body, loosen the two hex head cap screws to ensure adequate clearance. Install the body.
19. Install the pump body and the two rotors on the gearcase.
20. **R1, R2, R3 and R3HD Pumps Only.** Install the gasket. Install Nyliner bushing on 3HD cover and four hex nuts on the pump body. Tighten the hex nuts. Do Not over tighten.
21. **R4, R4HD, R6 and R6HD Pumps Only.** Install the gasket, install cartridge washer, cover and eight hex nuts on the pump body. Tighten the hex nuts. Do Not over tighten.

### **Daily Procedure for R4HDRI, R6HDRI, R700RI, R700HDRI, R4BHDRI, R6BHDRI and R700BHDRI Pumps**

1. Place a rubber mat under the immediate area of the pump to protect the parts which may drop accidentally.
2. Remove the product return tube and all other external piping as necessary.
3. **R700RI and R700BRI Pumps Only.** Tighten the hex nuts until the pump body is firmly against all pads on the gearcase.
4. Remove the two bearing end caps from the cover.
5. Remove the hex head cap screws, lockwashers and bearing retainer plates from the shaft ends.
6. Remove the nuts, cover and gasket from pump body. Do Not remove the retaining rings or the bearing outer races from the cover except as necessary for replacement.

**It may be necessary to tap the cover with a RUBBER MALLET to remove it from the pump body, or may use slide hammer in center hole to remove.**

7. Remove the front shaft seals and bearing inner races by holding firmly and rotating while pulling.
8. Remove the seal bearings and spacer cartridges from the shafts.
9. Remove the rotors from the pump shafts.
10. Install the spacer cartridges and seal bearings on the shafts.
11. Install the bearing inner races and the front shaft seals.
12. Install the gasket, cover and hex nuts on the pump body.

---

## Cleaning and Sanitizing

---

13. Install the bearing retainer plates, lockwashers and hex head cap screws on the shaft ends.
14. Install the bearing end caps on the cover.
15. Rinse the outer areas of the pump and gearcase (hand clean if necessary) according to standard plant procedure. For CIP cleaning, add sufficient cleaner to maintain a 1% causticity for duration of the cleaning cycle. Do Not leave rotors in the pump while cleaning the system.
16. When CIP is completed, remove the bearing end caps from the cover.
17. Remove the hex head cap screws, lockwashers and bearing retainer plates from the shaft ends.
18. Remove the hex nuts, cover and gasket from the pump body. Discard gasket.
19. Remove the front shaft seals and bearing inner races by holding firmly and rotating while pulling.
20. Remove the seal bearings and spacer cartridges from the shafts. Remove the O-rings from the spacer cartridges.
21. **R700RI Pump Only.** Remove the hex nut, cap screw and eye bolt from the pump body.
22. **RB700RI Pump Only.** Remove the two hex nuts, lockwashers and hook bolts from the brackets.
23. **R700BRI Pump Only.** Remove the pump body from the gearcase.
24. **R4HDRI and R6HDRI Pumps Only.** Loosen the two hex head cap screws enough to remove the pump body.
25. Remove the pump body from the gearcase.
26. **R4HDRI and R6HDRI Pumps Only.** Remove the rear shaft seals.
27. **R700RI Pump Only.** Remove the rear shaft seals and rear seal cartridges. Remove the O-rings from the rear seal cartridges.
28. Remove the seal bearings and O-rings from the shafts.
29. While the pump is disassembled, inspect all parts for excessive wear or damage and replace as necessary. Check the gearcase roller bearings for adjustment.
30. Clean all parts by hand using a general purpose alkaline solution at no greater than 1-1/2% caustic at a temperature of 110-120 F (45-50 C). To remove film of water stone or milk stone, use an acid cleaner.
31. When cleaning is completed, dry all parts thoroughly.
32. Apply sanitary lubricant to the O-rings and install in the grooves on the pump shafts. Slide the seal bearings over the O-rings.
33. **R700 Pump Only.** Apply sanitary lubricant to the O-rings and install on the rear seal cartridges. Install the rear seal cartridges on the shafts with the slots facing the rear.
34. **R700RI Pump Only.** Apply sanitary lubricant to the rear shaft seals and install in the cavity of the rear seal cartridges.

---

## Cleaning and Sanitizing

---

35. **R4HDRI and R6HDRI Pumps Only.** Prior to positioning the pump body on the gearcase, back off the cap screws to ensure that the pump body clears the gearcase studs.
36. **R700RI Pump Only.** Position the pump body so the inlet points up.
37. Position the pump body on the gearcase. Push the pump body flush against the gearcase.
38. **R700RI Pump Only.** Position the eye bolt in the bracket and install the cap screw in the pump body. Tighten the cap screw. Install the washer and the hex nut on the eye.
39. **R700BRI Pump Only.** Position the threaded ends of the hook bolts in the brackets and install the washers and hex nuts. Tighten the nuts alternately and ensure the pump is firmly against the pads of the gearcase.
40. Apply sanitary lubricant to all inside surfaces of the pump body and exterior surfaces of the rotors. Ensure the puller grooves face the front side of pump body (some rotors do not have puller grooves). Install the rotors.
41. Position the new gasket on the pump body and align with pins. This is a precision made gasket of exact thickness. Do Not substitute.
42. Apply sanitary lubricant to the O-rings and assemble them to the spacer cartridges. One O-ring fits inside of the cartridge and the other O-ring fits in the groove on outside of the cartridge.
43. Locate the seal bearings over the O-rings and press them onto the cartridges. Coat the cartridges with a sanitary lubricant, rotate the seal bearings until the square hole in the seal bearings match the shaft squares then slide the cartridges onto the shafts.
44. Place the bearing retainer plates over the ends of the shafts and insert the pins in the shaft ends. Align all tongues and grooves of the front seal and spacer cartridges, inner races of bearings and the bearing retainer plates.
45. Insert the hex head cap screws and lock washers in ends of the shafts, then tighten.
46. Slide the front shaft seals with their “V” sides facing the rotors into the bore of the cover until it is seated.
47. Align the holes in the cover to the pins in pump body and position cover over the studs and shafts. Push the cover evenly and firmly against the body to avoid dislodging the seals.
48. Install the hex nuts onto the studs and tighten.
49. After the cover hex nuts are securely tightened, tighten the hex head cap screws.
50. Connect the product return tubes and all other external piping.
51. Install the bearing end caps on the cover.
52. Inject Orange 501 type 0 lubricant into the bearing zerks.

---

## **Theory of Operation**

---

The rotary pump is normally connected to an electric or air powered hydraulic drive unit. When the electric drive unit is turned on, it rotates the rotors in the directions shown below.

As the shaft rotates, a pressure drop or vacuum is created at the product inlet causing product to flow into the pump. This is due to the interaction of the rotor lobes and the pump body.

As product flows into the pump, the rotor-to-rotor clearance is such that the product cannot flow between the rotors. However, the product may flow into the cavities between the rotor and the inner surface of the pump body.

Since the rotors are rotating during pump operation, the rotor cavities move from the inlet side of the pump to the outlet side of the pump. Therefore, product that entered the cavity on the inlet side of the pump is displaced from the inlet and moved to the outlet side of the pump.

When the product reaches the outlet side of the pump, it is discharged through the product outlet connection.

---

## Operation

---

**Prior to the operation of any rotary pump, it must be thoroughly cleaned and sanitized according to the instructions in the Cleaning and Sanitizing section.**

### **Starting the Pump**

1. Make sure that there is oil in the gear case, NOTE: Pump is shipped without oil
2. Start the water flow to the water flush seal (if applicable)
3. Open the suction line and allow product to flow to the product inlet connection
4. Open the discharge line
5. Start the pump drive

### **Stopping the Pump**

1. Stop the pump drive  
**Do not allow the pump to operate without product.**
2. Clean and Sanitize per instructions in the Cleaning and Sanitizing section

## Maintenance

### Lubrication

Always lubricate parts after disassembly for cleaning or maintenance. When processing food products, use a sanitary grade lubricant (approved for incidental contact with edible products) on all product contact surfaces during assembly.

Use high quality non-emulsifying gear oil. See partial listing of compatible gear oils below.

Oil	Manufacturer
A. m. Ind. Oil #51	American Indiana Oil Co.
American Industrial Oil #100	AMOCO
BP Energol H1 150	British Petroleum Company
Teresstic 100	Exxon
Lubricate HO-2A	Fiske Brothers
Harmony 100	Gulf
Teresstic or Teresso 65	Humble Oil & Refining Co. (Esso)
Mobile DTE Oil – Heavy	Mobile Oil Co.
Turbo Oil 100	Shell
Regal Oil R & O 100	Texaco
UNAX RX 100	Union (Eastern USA)
Turbine Oil 100	Union (Western USA)

APV cannot guarantee lubrication performance of these oils.

### Alternate Gearcase Oils

Pump Model	Top Feed Pumps	
	U.S.	Metric
R0	6.00 Ounces	0.18 Liter
R1	0.75 Pint	0.33 Liter
R2	0.75 Pint	0.33 Liter
R3	1.75 Pints	0.75 Liter
R4	3 Quarts	3.00 Liters
R6	3 Quarts	3.00 Liters
R700	3 Quarts	3.00 Liters

Gear Case Oil Capacities

Pump Model	Side Feed Pumps	
	U.S.	Metric
R0	7.50 Ounces	0.22 Liter
R1	1.00 Pint	0.50 Liter
R2	1.00 Pint	0.50 Liter
R3	2.25 Pints	1.20 Liters
R4	1.00 Gallon	4.00 Liters
R6	1.00 Gallon	4.00 Liters
R700	1.00 Gallon	4.00 Liters

Gear Case Oil Capacities

Item	Lubricant	Interval
Gearcase	See above	Check Weekly – Change every 500 hours
Rotors and Pump Interior	Sanitary Food Grade Lubricant*	Lubricate Daily at Assembly
Outboard Pump Bearings	#501 Type “O” Sanitary Lubricant	Lubricate Daily
Outboard Pump Bearings – Model 700	Orange Industria #390 Lubricant	Lubricate Daily
Electrical Drive Gearcase	See Manufacturer’s Recommendations	

### Recommended Lubricants and Lubrication Intervals

- \* When processing food products, use a sanitary grade lubricant approved for incidental contact with edible products (USDA Classification H1) on all product contact surfaces after disassembly for cleaning or maintenance.



---

## Maintenance

---

### Checking, Adding and Changing Oil

#### Contaminated Oil

Periodically check for accumulation of water in gearcase. If oil is heavily contaminated, change immediately.

#### Draining Oil

Place a suitable drain pan under drain plug. Remove drain plug and allow oil to drain until gearcase is completely empty. After oil is completely drained, install drain plug.

**The standard 3/8 inch pipe thread in gearcase for bushing permits extending an oil drainage line to any convenient point.**

#### Filling with Oil

Remove vent plug and fill pump to center of sight glass window with high grade gear lube (See gear oil recommendation table). Install filler plug.

#### Changing Oil in Top Feed Pumps

Place a suitable drain pan under drain plug. Remove drain plug and allow oil to drain until gearcase is completely empty. After oil is completely drained, install drain plug. Remove filler plug and fill pump to center of sight glass window with high grade gear lube. Install vent plug.

#### Changing Oil in R0 Pumps

Check oil level every week by removing one of two level plugs. Place a suitable drain pan under drain plug. Remove drain plug and allow oil to drain until gearcase is completely empty. After oil is completely drained, install drain plug. Remove breather plug and fill pump to level plugs with high grade gear lube. Install breather plug and level plug removed earlier.

**NOTE : Unit is shipped without gear case oil from factory.**

---

## Maintenance

---

### **Roller Bearing Adjustment (R0 Pump Only)**

1. Periodically inspect the gearcase for possible loose roller bearings. The best time to do this is when the pump parts have been removed from the gearcase for cleaning purposes.
2. Test for loose bearings by gripping the rotor shafts and attempting to move them in various directions. Excessive shaft looseness requires bearing replacement. However, in most cases a simple adjustment should be sufficient.

### **Adjusting Bearings**

1. Loosen the set screws. Loosen the top and bottom bearing adjusting nuts. This will free rotation of the shafts.
2. Rotate the top shaft back and forth. Tighten the top bearing adjusting nut until a slight resistance to the top shaft is felt. Mark the position of the top bearing adjusting nut and back it off one-half turn.
3. Rotate the bottom shaft back and forth. Tighten the bottom bearing adjusting nut until a slight resistance to the bottom shaft is felt. Lock the bottom bearing adjusting nut set screw after adjusting.
4. Turn the top bearing adjusting nut so that the marks line up.
5. Lock the top bearing adjusting nut set screw after aligning marks.
6. If bearing adjustment has been performed and the shafts are still loose, replace the bearings.

**Rotate the shafts back and forth 180° during bearing adjustment. Putting a crescent wrench on shaft squares will make turning of the shafts easier.**

**After 60 hours of run time, check the bearing adjustment nut on each shaft and tighten if necessary.**

---

## Maintenance

---

### **Roller Bearing Adjustment (All Pumps Except R0 Pump)**

1. Periodically inspect the gearcase for possible loose roller bearings. The best time to do this is when all pump parts have been removed from the gearcase for cleaning purposes.
2. Test for loose bearings by gripping the rotor shafts and attempting to move them in various directions. Excessive shaft looseness requires bearing replacement. However, in most cases a simple adjustment should be sufficient.

### **Adjusting Bearings**

1. Loosen the set screws. Loosen the top and bottom bearing adjusting nuts. This will free rotation of the shafts.
2. Rotate the top shaft back and forth. Tighten the top bearing adjusting nut, using a spanner wrench, until a slight resistance to the top shaft is felt. Mark the position of the top bearing adjusting nut and back it off one-half turn.
3. Rotate the bottom shaft back and forth. Tighten the bottom bearing adjusting nut, using a spanner wrench, until a slight resistance to the bottom shaft is felt. Lock the bottom bearing adjusting nut set screw with a screw driver after adjusting.
4. Turn the top bearing adjusting nut so that the marks line up.
5. Lock the top bearing adjusting nut set screw with a screw driver after aligning marks.
6. If bearing adjustment has been performed and the shafts are still loose, replace the bearing.

**Rotate the shafts back and forth 180° during bearing adjustment. Putting a crescent wrench on shaft squares will make turning of the shafts easier.**

**After 60 hours of run time, check the bearing adjusting nut on each shaft and tighten if necessary.**

---

## Maintenance

---

### Gearcase – R0 Pump

#### Disassembly

1. Remove the pump body and components from the gearcase.
2. Remove the drain plug and drain the oil.
3. Remove the four studs.
4. Remove the gearcase cover and the gearcase gasket. It may be necessary to tap the cover with a soft mallet to remove it.
5. Remove the shaft and the gear assemblies together with the bearings.
6. Remove the front and rear oil seals from the shafts
7. Remove the set screws from the gearcase cover.
8. Remove the bearing adjusting nuts from the gearcase cover. Remove the O-rings.
9. Remove the front and rear bearing cups.
10. Remove the bearing from the shafts. If a gear puller is not available for this purpose, it may be necessary to pry or break the bearing loose to remove them. In either case, be sure to protect all shafts at all times.

---

## Maintenance

---

### Assembly

1. Position the new O-rings into the gearcase cover and install the bearing adjusting nuts. Screw the bearing adjusting nuts in loosely, leaving one or two threads exposed.
2. Install the bearing cups in the gearcase and cover.
3. Press the bearings on the shafts.
4. Replace the studs.
5. Place the gearcase face down resting on the studs. Install the shaft assemblies, placing the long shaft in the top or the bottom position, whichever is required. Match the center punched tooth of one shaft, with the center punched space of the other shaft when mating the gears, as shown below.
6. Position the new gasket on the gearcase and install the gearcase cover. Replace and torque the four cover cap screws to 15 foot pounds (20.3Nm).
7. Stand the gearcase on the end with rotor shafts facing straight up. Position the new front oil seals in the seal cavities, spring side down. Work each seal evenly into cavity with a soft blunt tool until the outer seal face is flush with the seal cavity.  
Place the gearcase on the studs and replace the rear oil seal in the same manner, again with **spring side down**.
8. Install the drain plug. Fill the gearcase with oil (7.5 ounces / .22 liters for side feed pumps, 6 ounces / .18 liters for top feed pumps). Use equivalent lube.
9. Assemble the pump body and parts to the gearcase.

---

## Maintenance

---

### Gearcase – All Pumps Except R0 Pump

#### Disassembly

1. Remove the pump body and parts from the gearcase.
2. Remove the drain plug and drain the oil. Remove the sight glass and the breather plug.
3. Remove the studs. Note the position of the hex stud before removal so that this stud may be replaced in its correct position.
4. **For Pumps with Eight Studs Only.** Mark the four hex studs and the three round studs to ensure they are installed in the proper holes.
5. Using a large knife blade or similar thin tool, remove the seal rings. Twist the blade while turning the shaft to dislodge the ring.
6. Remove gearcase cover and gasket. It may be necessary to start cover by tapping it with a soft mallet.
7. Remove the front and rear oil seals from the shafts.

**The gearcase and the cover assembly are matched parts. Mark the assemblies so they cannot be interchanged with other similar pumps.**

8. Remove the set screws from the gearcase cover.
9. Remove the O-rings.
10. Note the position of the locating plugs and remove. Tap the plugs from inside the gearcase with a soft tool, preferably wood.
11. Remove the retaining rings, front bearing cup and rear bearing cup.
12. Remove the bearing from the shafts. If the gear puller is not available, it may be necessary to pry or break the bearing loose to remove. In either case, be sure to protect the finished surface of shafts at all times.

---

## Maintenance

---

### Assembly

1. Install the retaining rings in the gearcase.
2. Apply a light coat of Permatex No. 2 to the locating plugs and press firmly into place against the gearcase.
3. Position the new O-rings in the gearcase cover.
4. Install the front and rear bearing cups in the gearcase and cover.
5. Press the bearings on the shaft and gear assemblies.
6. Install the studs. Hex stud must be in upper left or lower right position, depending upon inlet position of the pump.
7. Place the gearcase face down resting on the studs. Install the shaft assemblies, placing the long shaft in the top or bottom position, whichever is required. Match the center punched tooth of one shaft with the center punched space of the other shaft when mating the gears as shown below.
8. Position the new gasket on the gearcase and install the gearcase cover. Install and evenly tighten the four cover cap screws.
9. Install the set screws and tighten.
10. Stand the gearcase on end with rotor shafts facing straight up. Position the new front oil seals in the seal cavities **spring side down**. Work each seal evenly into the cavity with a sort blunt tool until the outer seal face is flush with the seal cavity. Position gearcase on studs and replace rear oil seal in identical manner, again with **spring side down**.
11. Install the seal rings, angle side out, so that rear face of the seal ring is approximately 1/32 inch (1 mm) from front of the locating plug.
12. Install the drain plug. Fill the gearcase with oil.
13. Assemble the pump body and parts to the gearcase.

---

## Maintenance

---

### Oil Seal Replacement and Relocation (R0 Pump Only)

1. The front and rear oil seals should be inspected regularly and replaced before excessive leakage begins.
2. Check and replace the oil seals when oil leakage is noted at either of the following areas:
  - a. Around the driven shaft (rear of gearcase)
  - b. Where the gearcase attaches to the pump body (front of the gearcase)
3. When the seals have been neglected and/or where misuse has resulted in contamination of the gearcase, grooving of the shaft may occur where the seals contact the rotor shaft. If wear on the shaft is severe enough to prevent effective functioning of a new oil seal when placed in the old position, install it in a different spot on the shaft. Two relocations are normally possible without replacing the shaft even though severely worn. See the gearcase disassembly instructions to find out how to remove the oil seals from your particular pump.
4. Be sure to always use a new oil seal when relocating to a new position on the shaft. Use a blunt ended wood dowel to push the seal into position. Ensure the front oil seal is straight by measuring depth from the face of locating plug to the front of the seal at no fewer than four equidistant places around seal periphery. The rear oil seal is to be aligned straight with the rear face of the gearcase body. Reassemble the gearcase according to the instructions.

### Shaft Seal Insertion Procedure

#### Lubrication

Lightly lubricate the seal inside lip only. Do not lubricate the outside of the seal or the mating outside bore of the seal cavity. When processing food products, use a sanitary grade lubricant approved for incidental contact with edible products.

1. Assemble pump body onto gearcase before installing seal.
2. When installing seal by hand, push seal completely into cavity at one place with finger tip. Repeat until seal is completely seated all around. Press in and toward shaft.
3. An optional seal inserter tool is available to assist seal installation. The tool consists of two concentric plastic tubes, one inside the other. To operate:
  - a. Retract the inner tube ¼ in.
  - b. Install seal in outer tube with the rear of the seal facing outward.
  - c. Place tool with seal over pump shaft and hold firmly against pump body.
  - d. Push inner tube inward with twisting motion.
  - e. Check to see that seal is correctly and completely seated, all the way around.

#### Using the #4 and #6 Shaft Seal Inserter

1. Separate the inner tube from the outer tube. Lubricate the inner walls of the outer tube using a sanitary food grade lubricant.
2. Install one seal bearing ring with the opening end first (facing down) into the recessed area at the end of the inner tube. Then install a second seal bearing ring on the top of the first seal bearing ring with the open end facing outward. Place the seal over the outside of the seal bearing so the rear of the seal is contacting the seating surface at the end of the tube and the dot is facing outward.



3. Insert the inner tube and seal assembly into the largest end of the outer tube. Slowly push the inner tube in.
4. Stop when seal is approximately 1/16 inch from coming out the end of the outer tube.
5. Place the tool with the seal over the end of the shaft and press firmly against the pump body.
6. Push the inner tube inward installing the seal bearing and seal into cavity.
7. Check to see that the seal is correctly and completely seated into the seal cavity all the way around.
8. To only replace the seal without disassembly, install one seal bearing ring with the open end facing outward and protruding approximately 1/8" – 1/4" beyond the end of the inner tube. Place the seal over the outside of the seal bearing, so the rear of the seal is contacting the seating surface at the end of the tube and the dot is facing outward. Then repeat steps 3, 5, 6 and 7.

**Models R4HD, R6HD and R700 Rotary pumps have additional seals located in the front of the cover. Install these seals in the cavity of the cover, then install the cover onto the pump.**

Models R4HD, R6HD and R700, with the Degasser/Deaerator option, require seal location at the bottom of the cover cavity bore.

---

## Maintenance

---

### Rotors and Shafts

#### Removing Two Lobe Rotors (R0 Pump).

1. Always use special rotor puller furnished with R0 rotary pumps.
2. Insert puller as far as possible and over narrow section of rotor.
3. Hold other rotor with hand to prevent seizing.
4. Slight vertical and horizontal motion while pulling may aid in removal of rotor.

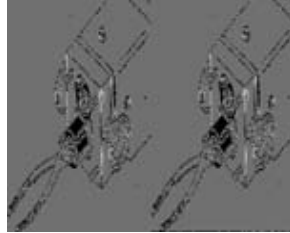

#### Removing standard Five Lobe Rotors (R3 thru R6)

A special 4-way (star) wrench is available for R3 through R6 sizes. One end of this puller engages grooves machined inside the square hole of stainless steel hub rotor (this puller will not work with heavy-duty model pumps).

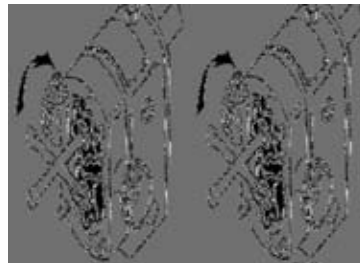

#### Removing Rotors With Heavy-Duty Puller (R4HD, R6HD and R700 Pumps)

1. Remove Pump cover and rinse rotors thoroughly with cold water.
2. Push puller onto rotor shaft until fingers engage slots in rotor. Slide puller into rotor groove to lock fingers solidly into slots.
3. Maintain firm side force to ensure that the puller fingers do not disengage rotor slots and that proper alignment of puller with shaft is maintained.
4. Turn screw clockwise to pull rotor from shaft.
5. After rotor has been removed, remove nylon pin and move puller in opposite direction to disengage fingers.

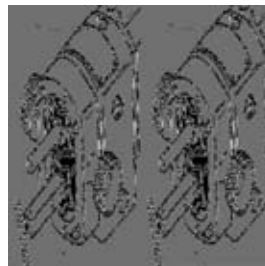

---

## Maintenance

---

### Shaft Wear

1. An important limitation of all optional rotors is that they not be used in pumps with excessive shaft wear. Shaft wear causes rotor to rotor interference during operation, which may bind pump and/or destroy rotors. If shaft dimension "A" is less than the value listed, excessive wear is present.
2. Measure dimension "A" at the edge of square shaft, no further in than dimension "B".

Pump Size No.	Dimension A	Dimension B
	Inch (mm)	Inch (mm)
R 1, R 2	0.824 (20.9)	¼ (6)
R 3	0.996 (25.3)	¼ (6)
R4, R6, R700	1.745 (44.3)	3/8 (10)

---

## Maintenance

---

### Field Reconditioning

As the pump body, cover and rotors of a rotary pump wear, pumping performance will decrease. Wear increases the clearances within the pump and the amount of “slip” or “blow by” experienced during operation. How much the wear will affect pump performance, depends on the application. Product viscosity, discharge pressure, pump speed, product temperature, suction conditions and required metering accuracy all have an effect.

The accompanying dimensional information lists like new critical dimensions which effect pump performance. As the body and cover wear, pumping efficiency will decrease. Although no rework can be done for wear to diameters “A” or “F”, the depth dimension “B” (standard body) can be re-established through proper machining by qualified machinists. The surface of the cover plate may also be reconditioned by surface grinding procedures. Do not machine any parts beyond the minimum dimensions stated.

The maximum amount of wear tolerable for the body bore diameter “A” will depend on the application as described above. As a general rule, the maximum wear for R0 pumps is .005 in. (0.13 mm) for R1, R2 or R3 pumps is .010 in. (0.25 mm) for R4, R6 or R700 pumps is 0.15 in. (0.38 mm).

### Re-working

To re-establish the original depth dimensions, machine surface “X” to clean up (maximum .030 in). The machine surface “Y” to re-establish the original “B” dimension (see chart), “C” dimension will be reduced by amount removed from surface “X”. Do not rework seal bore.

### Check After Machining

Removing metal from the “X” surface may allow the seal bearing to protrude into the pump body and hold the rotor away from the rear side (surface “X”). The rear side of the rotor must fit tight against surface “X”. Test with seal bearing on shaft and body pulled up tight. Use spacers to replace the cover and check with .002 in. feeler gauge. If rotors do not tighten, remove the shafts from the gearcase and remove what material is necessary from shoulders marked “Z”.

---

## Maintenance

---

Size	"A" Dia.	"B" Depth	"C" Dim.	"D" Dim	"E" Dim	"F" Dia.	"G" Dia.	"H" Dim.	"J" Dim.
R1	3.066	.553	0.284	1.277	2.555	1.499	1.140	0.824	0.310
R2	3.066	.831	0.284	1.277	2.555	1.499	1.140	0.824	0.310
R3	4.000	2.000	0.284	1.667	3.333	1.625	1.406	0.996	0.330
R4	6.000	2.400	0.375	2.500	5.000	2.938	2.535	1.745	0.485
R6	6.000	4.000	0.375	2.500	5.000	2.938	2.535	1.745	0.485
R700	6.000	8.000	N/A	2.500	5.000	N/A	N/A	1.745	0.280

Original Dimensions

### Preventive Maintenance Check List

#### Daily

1. Drain accumulated condensate from crankcase
2. Lubricate rotors with food grade lubricant
3. Wash pump body surfaces
4. Lubricate outboard bearings
5. CIP pump (without rotors in place)
6. Replace pump cover gasket
7. Lubricate shaft seals with food grade lubricant

#### Weekly

1. Check all hardware for tightness
2. Check gearcase oil level
3. Check vented cover for air leakage\*
4. Check for product leakage in incoming and outgoing lines

#### Monthly

1. Check condition of V belts
2. Check bearings and oil seals for wear
3. Check pump interior and cover for wear
4. Check rotors for wear
5. Check driven and drive pulleys for wear
6. Check overall condition of drive units
7. Make sure oil is changed regularly in drive units
8. Change oil in pump gearcase every 500 hours
9. Check shafts and rotor hubs for wear - corners must be square

\*Applies only to pumps equipped with vented covers.

## Maintenance

Symptoms	Rotary Pump Maintenance Tips
	Probable Causes
Low delivery	Speed too low. Using more than one cover gasket. Inlet "Starved". Rotors worn or seals worn.
Product leak	Shaft seal excessively worn. Seal bearing excessively worn. Seal parts improperly cleaned and lubricated. Nicks and burrs in seal cavity and seal bearing. Loose bearings. Abrasive product.
Excessive Bearing Wear	Oil contamination. Operating at excessive pressures and speeds. Improper bearing adjustment.
Oil contamination	Prolonged product leakage. Failure to drain condensate. Failure to change oil. Breather in wrong position. Oil seals improperly installed. Failure to clean gearcase front regularly.
Short shaft seal life	Running pump dry. Nicks in seal bearing. Nicks in seal cavity. Worn seal cavity. Improper seal installation/selection. Loose bearings. Excessive start/stop on viscous products.
Excessive rotor wear	Running pump dry. Pumping abrasive product. Circulating cleaning solutions. Nicks in body and cover. Excessive speeds and pressures. Extreme and sudden product temperature changes.
Rotor damage	Running pump dry. Hard substance through pump. Circulating cleaning solutions. Loose bearings. Nicks and burns in cover and body.
Poor suction lift	Pump speed too low. Using more than one cover gasket. Rotors excessively worn. Leak in suction line. No lubrication or liquid in pump. Cover excessively worn. Worn or damaged shaft seal.
Oil leak	Breather plugged. Oil seals excessively worn. Loose bearings. Excessive wear on shaft at contact with oil seal. Improper oil seal installation.
Excessive wear on shaft at contact with oil seals and excessive body wear on front outlet pump	Excessive exposure of oil seals to external abrasives. Oil contamination. Failure to clean gearcase front regularly. Excessive discharge pressure.
In vacuum pan operation pump fails to start or maintain pumping	Inlet not flooded. Rotors excessively worn. Pump speed too low. No check valve down stream from pump. Check valve defective. Leaks in suction line. Seals excessively worn or damaged.
Noisy pump operation	"Starved" inlet. Excessive clearance between rotor and shaft. Loose bearings. Oil contamination.
Pump drive to stall when pumping high temp. product (150° F) (66° C) or higher	Drive horsepower rating at operating speed inadequate. Drive belt worn. Drive pulley worn.
Stall at low variable speeds	Inadequate horsepower rating.
Light to moderate cover scoring (no ill effects on pump)	Normal mechanical forces.
Excessive cover wear	Running dry. Excessive pressure and speeds. Abrasive products.
Degasser not effective	Incorrect sleeve installed.

---

## Options

---

### Vented Cover

#### Field Installation

**Refer to the illustrations on the following pages for component locations.**

1. Remove the standard cover and then remove four of the standard studs and replace them with the special longer vented cover studs included with the cover. If your pump is an R1, R2 or R3 pump, remove all four studs. If it is an R4 or R6 model, **remove only the four studs nearest the pump cover center.**

**Prior to removing the single hex stud, carefully note its position in the gearcase; then make sure that the longer vented cover hex stud goes into the same hole that the standard hex stud was removed from.**

2. Locate the new inner cover in position on the studs with the grooved side toward the pump body. The large stud hole in the inner cover goes over the hex stud.
3. Place the rubber covered gasket over the four vented cover studs and then place outer cover over studs. If your pump is an R1, R2 or R3 model, locate the large stud hole in outer cover over the hex stud. If your pump is an R4 or R6 model, place outer cover next to the gasket so that the arrow stamped on inner cover coincides with the arrow stamped on outer cover.
4. Place hex nuts on all studs and tighten them securely and evenly with the standard pump wrench.
5. Position plunger inside the threaded sleeve of the outer cover.
6. Assemble lock nut on the threaded sleeve, chamfered side in. Turn nut clockwise to a point near the bottom of the thread.
7. Position spring so that it is seated in the recess of the plunger.
8. Place adjusting nut on the threaded sleeve. Turn nut clockwise about two or three turns only. This is the position of maximum safety and protection when beginning final adjustment of the vented cover to the desired venting pressure.
9. The procedure discussed in items 2 through 3 is to be used when assembling the cover for manual operation. For pneumatic operation of cover, the following procedure is recommended:
  - a. Proceed as described in items 2 and 3 above, but omit the plunger and spring.
  - b. Turn adjusting nut clockwise as far as it will go and then tighten lock nut. Do not attempt to seal the assembly against air leakage. A slight air leak is advantageous to operation and adjustment of the vented cover.

#### Cleaning

Since only the inner cover and rubber cover gasket are exposed to the product, these are the only parts that require thorough cleaning. The remainder of the vented cover assembly need not be disassembled for cleaning and the adjustment need not be disturbed. Simply submerge the cover in a wash tank and then place it in a position to drain. All parts should be placed on a rubber mat. Avoid nicking metal parts, particularly the inside face of the cover. Clean the rest of the pump according to recommended cleaning procedure.

---

## Options

---

### Manual

Pump discharge pressure tends to push the rubber cover gasket and plunger towards the front of the pump. This pressure compresses spring allowing pressure to be relieved by escaping via the rear side of the gasket and the recess of the outer cover. The venting pressure can be set by adjusting spring tension with the adjusting nut.

### Adjusting Vented Cover – Manual Operation

1. Place a pressure gauge in the downstream line close to the pump; between the pump and other downstream equipment.
2. Place a shut-off valve in the discharge line immediately downstream from the pressure gauge. Leave the valve wide open.
3. Loosen the lock nut and turn the adjusting nut clockwise as far as it will go. This is to prevent any venting during Step 4 below.
4. Pump product through system at the desired temperature and adjust the pump speed until the desired capacity is attained.
5. Check the pressure gauge for the desired pumping pressure. Example: 40 psig (2.8 kg/cm<sup>2</sup>).
6. Determine the venting pressure needed to protect the system. Example: 45 psig (3.15 kg/cm<sup>2</sup>). Venting pressure must always be higher than the pumping pressure.
7. Now turn the adjusting nut counterclockwise until only two or three threads are engaged.
8. Close the valve in discharge line until the gauge reads desired venting pressure. Example: 45 psig (3.15 k/cm<sup>2</sup>).
9. Slowly close the vented cover adjusting nut until gauge reads 1 psig (0.7 kg/cm<sup>2</sup>) more than the desired venting pressure. Example: 46 psig (3.22 kg/cm<sup>2</sup>). Then tighten the lock nut against the adjusting nut.
10. Fully open the valve in discharge line. The vented cover will now relieve and protect the system at 45 psig (3.15 kg/cm<sup>2</sup>).



---

## Options

---

### **Pneumatic**

Air pressure on the front side of the cover gasket tends to close the discharge to inlet passage behind the gasket and discharge pressure opens it. Venting pressure is determined by the amount of air pressure applied.

### **Adjusting Vented Cover – Pneumatic Operation**

1. Place a pressure gauge in the downstream line close to the pump; between the pump and other downstream equipment.
2. Place a shut-off valve in discharge line immediately downstream from pressure gauge. Leave valve wide open.
3. Attach an air line to the adjusting nut at the 1/8 inch (3 mm) pipe tapped hole provided. Install a pressure gauge and pressure regulator in the air line at a convenient distance from the pump so the gauge will show air pressure being applied to the vented cover. Set the air pressure at a maximum. This will prevent any venting during Step 4.
4. Pump product through the system at the desired temperature and adjust the pump speed until desired capacity is attained. Note the operating pressure on the gauge when capacity is reached.
5. With the pump running as in Step 4, reduce the air pressure to 0 psig. Close the valve in the discharge line. Increase the air pressure until the gauge in the discharge line shows pressure equal to desired venting pressure.
6. Open the valve in the discharge line completely.

---

## Options

---

### **Water Flush Seal Kit**

The water flush seal kit includes special locating plugs and piping for water into and out of the seal area.

Water flush seals are advantageous for applications where products contain sugars, or other ingredients that may crystallize when exposed to air. Flooding the seals with water lubricates them and prevents build-up of abrasive crystallized product.

Water flows to the bottom of the pump, fills the chamber and then flows out of the top of the pump. Water must flow in this direction to prevent air entrapment.

Water flush seals are available for all standard size pumps for field conversion.

---

## Options

---

### Flanged Hopper Rectangular Inlet

#### Installation

1. The flanged hopper may be constructed by the user, or it may be supplied with the pump in which case it is equipped with a hopper support which can be mounted on a standard pump base.
2. The independent suspension of the APV hopper provides the support necessary to prevent distortion and misalignment of pump parts. In addition, it simplifies assembly and disassembly of the pump for cleaning operations.
3. For hoppers which are heavily loaded, it may be necessary to provide them with separate supports. However, care should be exercised in the initial installation to prevent the supports from interfering with pulling the hopper and pump angles together securely.
4. Provisions for shimming or adjusting such supports for proper alignment between the hopper and pump are essential for efficient operation. In some cases it may be convenient to utilize adjustable feet on the pump and drive assembly.

**Be sure adequate support is provided for hoppers which are constructed and mounted by the user. It is important also that the inlet of the pump be tightly sealed so that a vacuum is developed by the pump.**

#### Cleaning

1. Because of the arrangements made by APV for the cleaning of the rectangular inlet pump, it is possible to run many different products through the pump each day with a minimum of downtime required between each product change.
2. For the cleaning procedure, the rotors and cover are the only items that need to be removed from the pump and washed separately. After these items have been washed, apply a stream of hot water to the underside of the pump directly between the body and gearcase and upwards toward the shafts to flush out any product leakage that may have occurred in this area. Wash out any other product contact surfaces with hot water and then put rotors and cover back on pump.

**When placing rotors on their shafts, they must slide in freely. If they rub or contact the edge of the cavity, the pump and gearcase could be out of alignment because the hopper is creating a pressure to the pump.**

---

## Options

---

### Degasser – Deareator

#### General Description

The purpose of the unit is to remove gas pockets from yeast bakery products or meat emulsions. When gas pockets are removed from yeast, the fineness in texture and smoothness in appearance is enhanced considerably. Removing gas pockets also increases the accuracy of weight control.

#### Product Flow

The hopper is filled with gaseous dough and the pump is turned on. The rotation of the pump rotors creates a slight vacuum at the bottom of the hopper. The dough is pulled into the rotor area. Each rotor pocket becomes partially filled with product. Partially filled rotor pockets are isolated as the rotors rotate in the pump cavity. The entrapped gas in the rotor pockets migrates from the product to the partial vacuum in the pockets. As the pockets containing the product approach a higher pressure (the discharge side of the pump), the gas is compressed and forced into the recessed face area of the rotor. From there, the gas is vented to the atmosphere through venting holes in the front cover of the pump.

The venting holes in the front cover are positioned to permit maximum gas venting while minimizing the amount of product escape. Any product that does escape will be returned to the hopper through the product return pipe.

**Plugs located on R4RI and R6RI pumps only, act as spacers to prevent too much bypass of air/product mixture through the recessed face area of the rotors.**

---

## MANUFACTURING FACILITIES

### **Goldsboro, NC**

1200 W. Ash Street  
P.O. Box 1718  
Goldsboro, NC 27533  
Tel: 919-735-4570  
Fax: 919-735-5275

### **Delavan, WI**

611 Sugar Creek Road  
Delavan, WI 53115  
Tel: 888-278-4321

Factory Direct Sales Service Parts Sales, Toll Free 1-888-278-4321

---

## REGIONAL OFFICE

### **Amherst, NY**

105 CrossPoint Pkwy  
Getzville, NY 14068  
Tel: 716-692-3000  
Fax: 716-692-1715

---

## SERVICE CENTER

### **Houston Service Center**

1101A Pleasantville Dr.  
Houston, TX 77029  
Tel: 888-278-1030  
Fax: 888-278-1050

### **Tulare Service Center**

836 East Levin  
Tulare, CA 93274  
Tel: 559-685-7400  
Fax: 559-685-5241

---

---

## **CANADA**

### **Toronto**

3280 Langsta Road  
Concord, Ontario  
L4K 4Z8 Canada  
Tel: 905-760-1852  
Fax: 905-760-1865

---

## **INTERNATIONAL**

APV Japan  
1200-1, Ogura, Saiwai-Ku  
Kawasaki 212 0054  
Japan  
Tel: 81 44 599 4095  
Fax: 81 44 599 4508

APV Mexico  
Calle Amargura No. 60  
Colonia Lomas de la Herradura, Huixquilucan  
Estado de Mexico 52760  
Mexico  
Tel: 525 555 263 0100  
Fax: 525 555 557 2620

APV South America  
Rua João Daprat 231  
São Bernardo do Campo, SP 09600-010  
Brazil  
Tel: 55 11 21APVAPV (21 278 278)  
Fax: 55 11 21APV260 (21 278 260)

---



# Spare Parts Manual R Series Positive Displacement Pump



Read and understand this manual prior to operating or servicing this product.



# MODEL R0

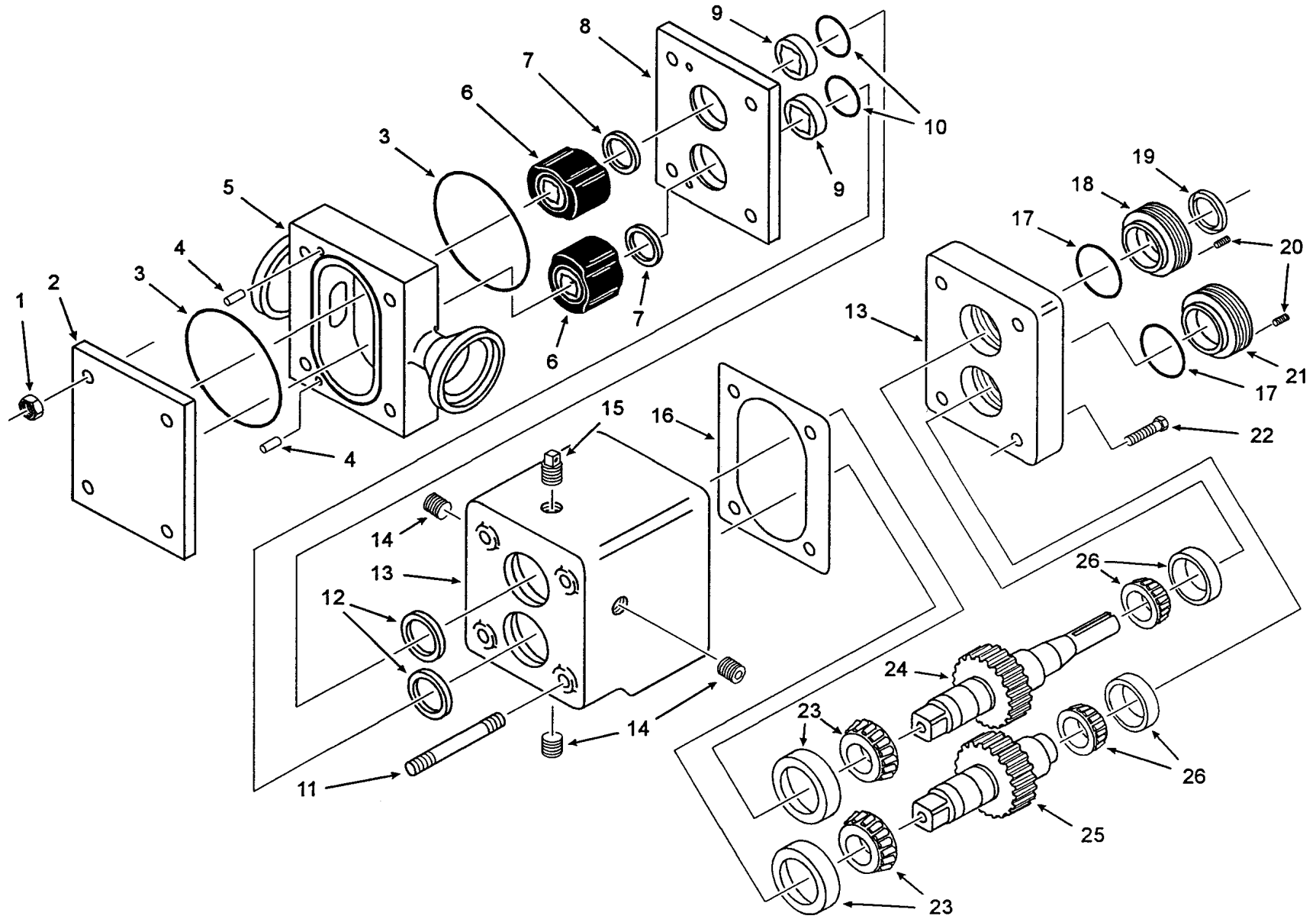



## MODEL R0

ITEM	DESCRIPTION	QTY.	PART NO.
1	NUT - Hex (Stainless Steel)	4	M523V006515
2	COVER	1	M03HP331499
3	GASKET - Cover	2	M543S131417
4	PIN - Dowel	2	M525S1670J
5	BODY	1	See BODY OPTIONS
6	ROTOR - 2 Lobe	2	See ROTORS
7	SEAL - Shaft (sold in pks of 10pcs)	2	See SEALS
8	BACKPLATE	1	M03HP331037
9	BEARING - Seal (Stainless Steel)	2	M03HP331051
10	O-RING - Pump Seal (sold in pks of 10pcs)	2	M543S131312
11	STUD - Hex	4	M03HP331077
12	SEAL - Front Oil	2	M543SP188
13	GEAR CASE and COVER ASSEMBLY	1	See GEARCASE OPTIONS
14	PLUG - Pipe	3	M567SF043B
15	BREATHER	1	M567SG554
16	GASKET - Gear Case	1	M549P353681
17	O-RING - Rear Bearing Seal (sold in pks of 10p	2	M543S1313CT
18	NUT - Bearing Adjustment and Seal Retainer	1	M03HP331031
19	SEAL - Rotor Oil	1	M543SP188
20	SCREW - Set	2	J820149
21	NUT - Bearing Adjustment	1	M03HP331030
22	SCREW - Hex Head Cap	4	M521V007222
23	BEARING - Front - Tapered Roller Bearing	2	M621S4158T
24	SHAFT and GEAR ASSEMBY - Long	1	M03AP331034
25	SHAFT and GEAR ASSEMBY - Short	1	M03AP331036
26	BEARING - Rear - Tapered Roller Bearing	2	M621S4158T
see TOOLS	ROTOR PULLER	1	M03AP367535
see TOOLS	SEAL INSERTER	1	M03AP353666

## MODEL R0

### BODY OPTIONS

ITEM	DESCRIPTION	QTY.	PART NO.
8	BODY - 1.5" Butt Weld	1	M03AP331046
8	BODY - 1.5" Bevel Seat	1	M03AP331041
8	BODY - 1.5" Th'd PV Seat	1	M03AP331042
8	BODY - 1.5" PV Clamp	1	O/A
8	BODY - 1.5" ISS	1	M03AP331044
8	BODY - 1.5" Tri-Clamp	1	M03AP331045
8	BODY - 1.5" Cherry Burrell "I"	1	O/A
8	BODY - 1.5" Flange	1	O/A

### GEARCASE OPTIONS

ITEM	DESCRIPTION	QTY.	PART NO.
13	GEAR CASE and COVER ASSY	-	M03AP337385

GEAR CASE ASSEMBLY - INCL SHAFTS - (Includes Items 12-26 shown on previous page)

13A	GEAR CASE ASSY - TOP SHAFT	-	M03AP356090
13A	GEAR CASE ASSY - BOTTOM SHAFT	-	M03AP356091
27	SUPPORT BRACKET - for top inlet option	-	M03AP365321

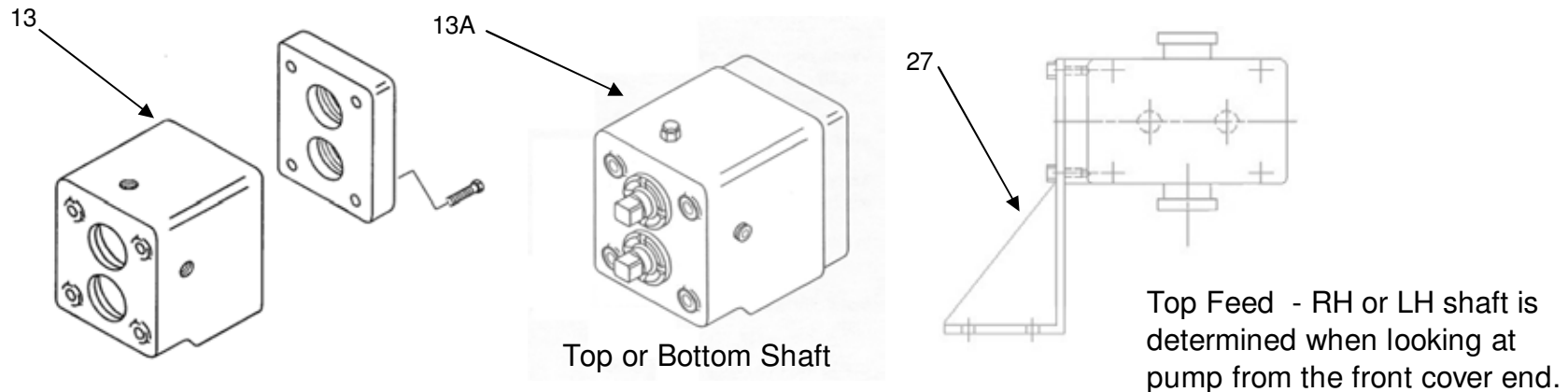

# MODELS R1, R2, R3, AND R3HD

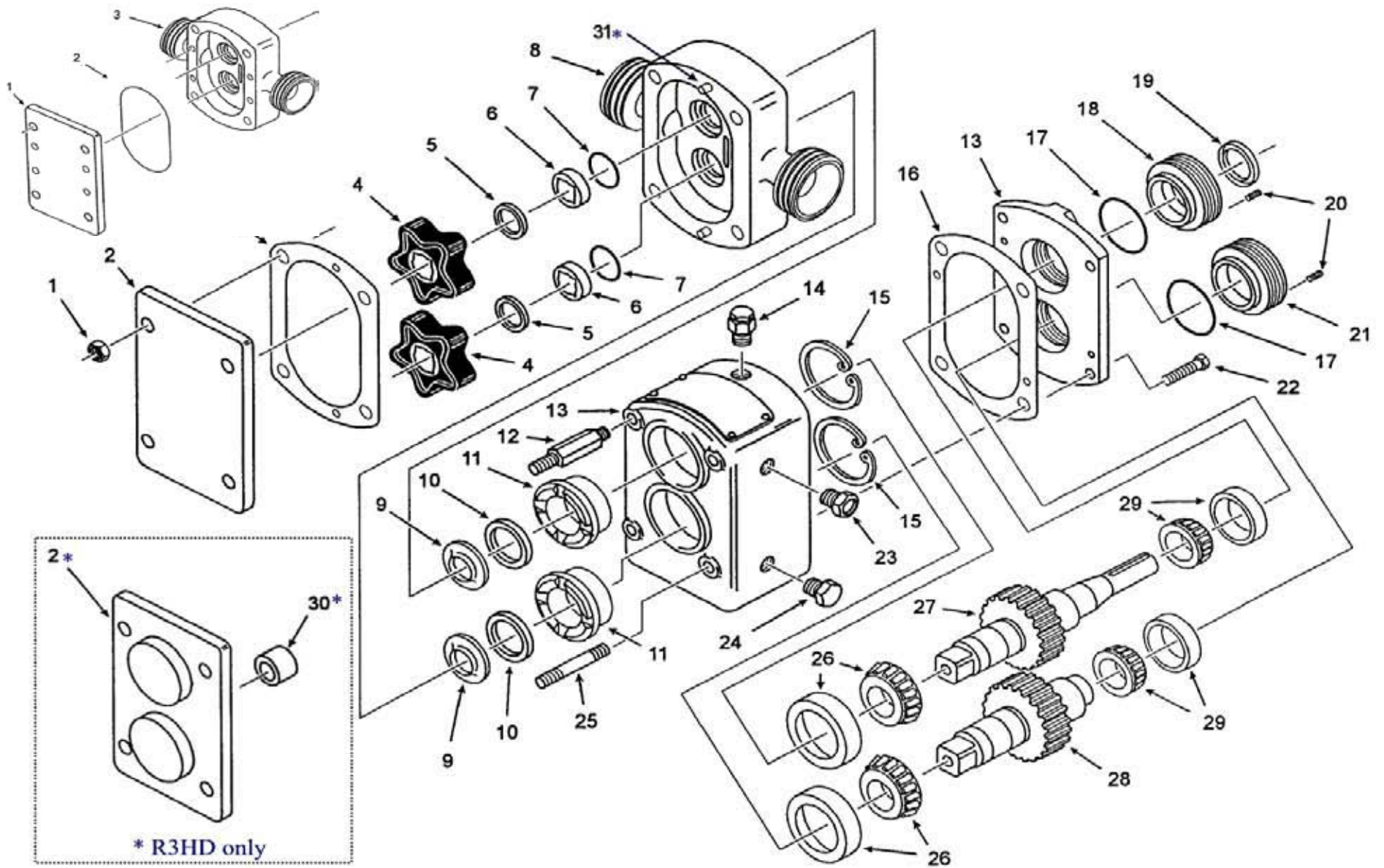

## MODELS R1, R2, R3, AND R3HD

ITEM	DESCRIPTION	PART NUMBERS				
		QTY.	R1	R2	R3	R3HD
1	NUT - Hex (Stainless Steel)	4	M523V005033	M523V005033	M523V006529	M523V006529
	NUT - Wing (optional)	4	M523SR607A	M523SR607A	M727P397882	M727P397882
2	COVER	1	M03HP133517	M03HP133517	M03HP133588	M03AP228363
	COVER - Vented cover (optional) - see options	1	see VENTED COVER section			N/A
	COVER - Front - (Option: Deaerator/Degasser)	1	N/A	N/A	M03AP262079	N/A
3	GASKET - Cover (Paper) - (sold in pks of 100)	1	M541P133526	M541P133526	M541P133075	M541P225153
4	ROTORs - 5 Lobe	2	See Rotors	See Rotors	See Rotors	See Rotors
5	SEAL - Shaft (sold in pks of 10pcs)	2	See Shaft Seals	See Shaft Seals	See Shaft Seals	See Shaft Seals
6	Brg seal (SS)	2	M03HP137709	M03HP137709	M3HP137713	M03HP137713
7	O-RING - Pump Seal (sold in pks of 10pcs)	2	M543S131316	M543S131316	M543S131320	M543S131320
8	BODY	1	see BODY OPTIONS			
9	RING -Seal (sold in pkcs of 10pcs)	2	M03HP137708	M03HP137708	M03HP137722	M03HP137722
10	SEAL - Front Oil	2	M543SP190	M543SP190	M543SK608	M543SK608
11	PLUG - Locating	2	M03HP133539	M03HP133539	M03HP133572	M03HP133572
	PLUG - Locating - (Option: Water flush seal)	2	M03HP304880	M03HP304880	M03HP255923	M03HP255923
12	STUD HEX - standard front cover	1	M03HP222069	M03HP144275	M03HP137762	M03HP137762
	STUD HEX - (Option: See Vented Cover section)	1	see VENTED COVER section			N/A
13	GEAR CASE ASSEMBLY --see Gearcase section	1	see GEARCASE section			
14	PLUG - vent (breather)	1	M569P454192	M569P454192	M569P454192	M569P454192
15	RING - Retaining	2	M524S4806H	M524S4806H	M524S4806J	M524S4806J
16	GASKET - Gear Case	1	M549P144399	M549P144399	M549P133596	M549P133596
17	O-RING - Rear Bearing Seal (sold in pks of 10pcs)	2	M543S131403	M543S131403	M543S131411	M543S131411
18	NUT - Bearing Adjustment & Seal Retainer	1	M03HP133538	M03HP133538	M03HP138303	M03HP138303
19	SEAL - Rear Oil	1	M543SP189	M543SP189	M543SK608	M543SK608
20	SCREW - Set	2	M522V008777	M522V008777	M522V006970	M522V006970
21	NUT - Bearing Adjustment	1	M03HP156447	M03HP156447	M03HP156448	M03HP156448
22	SCREW - HEX HD	4	M522V006754	M522V006754	M522V006754	M522V006754
23	SIGHT GLASS	1	M569P454191	M569P454191	M569P454191	M569P454191
24	OIL PLUG	2	M569P454190	M569P454190	M569P454190	M569P454190
25	STUD ROUND - standard front cover	3	M03HP222068	M03HP133532	M03HP133574	M03HP133574
	STUD round - (Option: See Vented Cover section)	3	see VENTED COVER section			N/A
26	BEARING - Front - Tapered Roller	2	M621S4158D	M621S4158D	M621S4158G	M621S4158G
27	SHAFT & GEAR ASSEMBLY - Long	1	M03AP210968	M03AP137711	M03AP137759	M03AP225669
28	SHAFT & GEAR ASSEMBLY - Short	1	M03AP210967	M03AP137766	M03AP137721	M03AP225668
29	BEARING - Rear - Tapered Roller	2	M621S4158E	M621S4158E	M621S4158H	M621S4158H
30	NYLINER BUSHING - (R3HD only)	2	N/A	N/A	N/A	M621S5863A
31	DOWEL PIN - (R3HD only)	2	N/A	N/A	N/A	M525S1670F

## MODELS R1, R2, R3, AND R3HD

### BODY OPTIONS

ITEM	DESCRIPTION	QTY.	PART NUMBERS			
			R1	R2	R3	R3HD
8	BODY - 1.5" Butt Weld	1	M03AP254916	M03AP171313	M03HP171283	M03AP232874
8	BODY - 1.5" Bevel Seat	1	M03AP254910	M03AP133516	M03AP133589	M03AP232860
8	BODY - 1.5" Th'd PV Seat	1	M03AP254911	M03AP171309	M03AP171331	M03AP232868
8	BODY - 1.5" PV Clamp	1	M03AP254918	M03AP171311	M03AP171333	M03AP232870
8	BODY - 1.5" ISS	1	M03AP254915	M03AP171302	M03AP171324	M03AP232861
8	BODY - 1.5" Tri-Clamp	1	M03AP254914	M03AP171312	M03AP171334	M03AP232871
8	BODY - 1.5" Cherry Burrell "I"	1	M03AP254920	M03AP171305	M03AP171327	M03AP232864
8	BODY - 1.5" Flange	1	-	M03AP171314	M03AP309402	M03AP232875
8	BODY- 2in. - Butt Weld	1	N/A	N/A	M03HP343375	M03AP406163
8	BODY - 2" Bevel Seat	1	N/A	N/A	M03AP229075	M03AP232886
8	BODY - 2" Th'd PV Seat	1	N/A	N/A	M03AP265825	M03AP307683
8	BODY - 2" PV Clamp	1	N/A	N/A	M03AP265828	M03AP452733
8	BODY - 2" ISS (APV-SP) Clamp	1	N/A	N/A	M03AP265826	M03AP319059
8	BODY - 2" Tri-Clamp	1	N/A	N/A	M03AP197700	M03AP232884
8	BODY - 2" Cherry Burrell "I"	1	N/A	N/A	M03AP265827	M03AP452734
8	BODY - 2in. - Flange	1	N/A	N/A	M03AP265832	M03AP452735

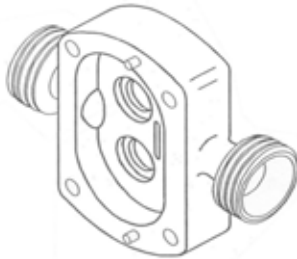

NOTE: Pin shown on illustration is only on R3HD pump.

## MODELS R1, R2, R3, AND R3HD

### GEARCASE OPTIONS

ITEM	DESCRIPTION	PART NUMBERS				
		QTY.	R1	R2	R3	R3HD
13	GEAR CASE & COVER ASSEMBLY - Std Mt	1	M03AP469372	M03AP469372	M03AP465980	M03AP465980
13	GEAR CASE & COVER ASSY- Top Feed - Pedestal Mt	1	M03AP180584	M03AP180584	M03AP469448	M03AP469448
13	GEAR CASE & COVER ASSEMBLY - WFS - Std Mt	1	M03AP454080	M03AP454080	M03AP454082	M03AP454082
13	GEAR CASE & COVER ASSY-Top Feed-Ped Mt-wfs	1	M03AP454081	M03AP454081	N/A	N/A
13	GEAR CASE & COVER ASSY-Top Feed-Floor Mount	1	N/A	N/A	M03AP255718	M03AP255718

### GEAR CASE ASSEMBLY - INCL SHAFTS - (Includes Items 9-29, excluding #12 & #25)

13A	GEAR CASE ASY - SIDE FEED - TOP SHAFT	-	M03AP454759	M03AP454696	M03AP454819	M03AP454686
13A	GEAR CASE ASY - SIDE FEED - BOTTOM SHAFT	-	M03AP454760	M03AP454697	M03AP454820	M03AP454687
13A	GEAR CASE ASY -TOP FEED - RH SHAFT-PED MT (*)	-	M03AP454847	M03AP454843	M03AP454823	M3AP454690
13A	GEAR CASE ASY - TOP FEED - LH SHAFT-PED MT (*)	-	M03AP454848	M03AP454844	M03AP454824	M03AP454691
13A	GEAR CASE ASY -TOP FEED - RH SHAFT-FLR MT	-	N/A	N/A	M03AP454827	M03AP454694
13A	GEAR CASE ASY - TOP FEED - LH SHAFT-FLR MT	-	N/A	N/A	M03AP454828	M03AP454695

(\*) Assembly includes items 32, 33 and 34

### GEARCASE ASSEMBLY OPTIONS - WATER FLUSH SEAL (Includes Items 9-29, excluding #12 & #25)

13A	GEAR CASE ASY - SIDE FEED - TOP SHAFT	-	M03AP454761	M03AP454716	M03AP454821	M03AP454688
13A	GEAR CASE ASY - SIDE FEED - BOTTOM SHAFT	-	M03AP454762	M03AP454717	M03AP454822	M03AP454689
13A	GEAR CASE ASY -TOP FEED - RH SHAFT-PED MT (*)	-	M03AP454849	M03AP454845	M03AP454825	M03AP454692
13A	GEAR CASE ASY - TOP FEED - LH SHAFT-PED MT (*)	-	M03AP454850	M03AP454846	M03AP454826	M03AP454693

(\*) Assembly includes items 32, 33 and 34

### GEARCASE & PLUG ASSY - (includes items 13,14,18, 21, 22, 23, 24 - does not include item 16 gasket)

13B	GEAR CASE & PLUG ASSEMBLY	1	M03WP469372	M03WP469372	M03WP465980	M03WP465980
-----	---------------------------	---	-------------	-------------	-------------	-------------

32	SUPPORT POST - PEDESTAL MOUNT	-	M03HP180581	M03HP180581	M03HP177997	M03HP177997
33	SUPPORT BRACKET - PEDESTAL MOUNT	-	M03HP180582	M03HP180582	M03HP177733	M03HP177733
34	GASKET - SUPPORT POST	-	M549P133577	M549P133577	M549P133577	M549P133577

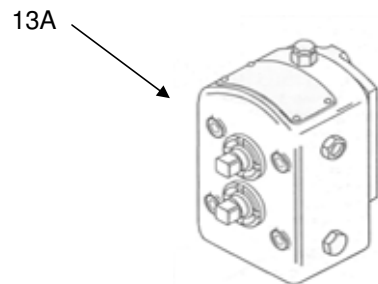
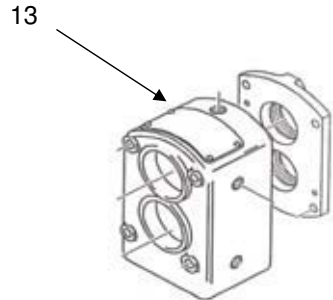

Top or Bottom Shaft

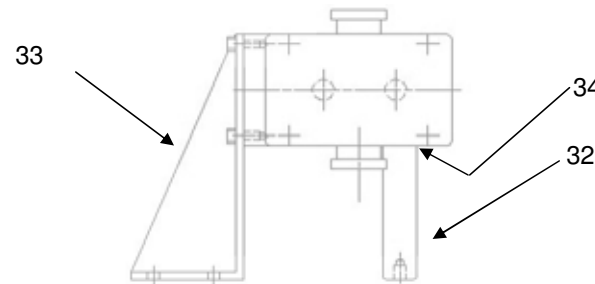

Top Feed - RH or LH shaft is determined when looking at pump from the front cover end. Support post, bracket and gasket (#32, 33, 34) is only included with gear case assemblies marked with an asterisk (\*).

# MODELS R2RI, R3RI, R3HDRI

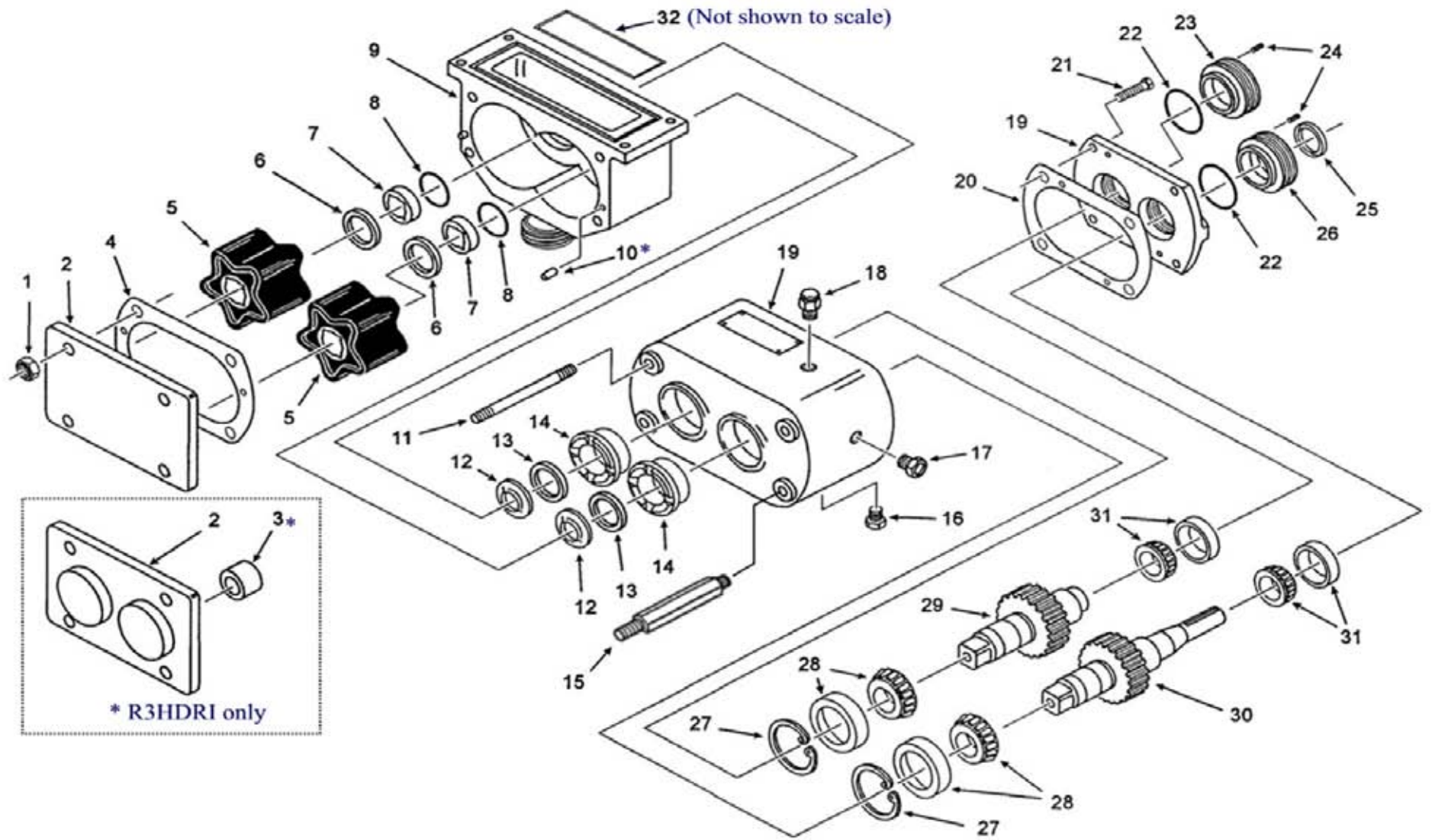



## MODELS R2RI, R3RI, R3HDRI

ITEM	DESCRIPTION	QTY.	PART NO.		
			R2RI	R3RI	R3HDRI
1	NUT - Hex (Stainless Steel)	4	M523V005033	M523V006529	M523V006529
1	NUT - Wing	4	M523SR607A	M727P397882	M727P397882
2	COVER - STANDARD FLAT COVER	1	M03HP232138	M03HP133588	M03AP228363
	(see FRONT COVER SECTION FOR ADDITIONAL OPTIONS)				
3	BUSHING - Nyliner	2	N/A	N/A	M621S5863A
4	GASKET - Cover (Paper) (sold in pks of 100pcs)	1	M541P232139	M541P133075	M541P225153
5	ROTORS - 5 Lobe	2	See Rotors	See Rotors	See Rotors
6	SEAL - Shaft	2	See Seals	See Seals	See Seals
7	BEARING - Seal (Stainless Steel)	2	M03HP137709	M03HP137713	M03HP137713
8	O-RING - Pump Seal (sold in pks of 10pcs)	2	M543S131316	M543S131320	M543S131320
9	BODY	1	see BODY OPTIONS		
10	DOWEL	2	N/A	N/A	M525S1670F
11	STUD - Round	3	M03HP133532	M03HP133574	M03HP133574
12	RING - Seal (sold in pks of 10pcs)	2	M03HP137708	M03HP137722	M03HP137722
13	SEAL - Front Oil	2	M543SP190	M543SK608	M543SK608
14	PLUG - Locating	2	M03HP133539	M03HP133572	M03HP133572
	PLUG - Locating - (Option: Water flush seal)	2	M03HP304880	M03HP255923	M03HP255923
15	STUD - Hex	1	M03HP144275	M03HP137762	M03HP137762
16	OIL PLUG	1	M569P454190	M569P454190	M569P454190
17	SIGHT GLASS	1	M569P454191	M569P454191	M569P454191
18	BREATHER/OIL FILLER	1	M569P454192	M569P454192	M569P454192
19	GEARCASE ASSEMBLY	1	see GEARCASE section		
20	GASKET - Gear Case	1	M549P144399	M549P133596	M549P133596
21	SCREW	4	M521V006754	M521V006754	M521V006878
22	O-RING - Rear Bearing Seal (sold in pks of 10pcs)	2	M543S131403	M543S131411	M543S131411
23	NUT - Bearing Adjustment	1	M03HP156447	M03HP156448	M03HP156448
24	SCREW - Set	2	M522V008777	M522V006970	M522V006970
25	SEAL - Rear Oil	1	M543SP189	M543SK608	M543SK608
26	NUT - Bearing Adjustment & Seal Retainer	1	M03HP133538	M03HP138303	M03HP138303
27	RING - Retaining	2	M524S4806H	M524S4806J	M524S4806J
28	BEARING - Front - Tapered Roller	2	M621S4158D	M621S4158G	M621S4158G
29	SHAFT & GEAR ASSEMBLY - Short	1	M03AP137766	M03AP137721	M03AP225668
30	SHAFT & GEAR ASSEMBLY - Long	1	M03AP137711	M03AP137759	M03AP225669
31	BEARING - Rear - Tapered Roller	2	M621S4158E	M621S4158H	M621S4158H
32	RI Gasket	1	M03HP232146	M03HP334133	M03HP334133



## MODELS R2RI, R3RI, R3HDRI

### FRONT COVER OPTIONS

ITEM	DESCRIPTION	QTY.	PART NO.		
			R2RI	R3RI	R3HDRI
2	COVER - Deaerator/Degasser 1.5" in.	1	N/A	M03AP262079	N/A
2	COVER - Front Outlet - 2 in. Th'd Bevel Seat	1	N/A	M03AP257456	M03AP321736
2	COVER - Front Outlet - 2 in. Th'd PV Seat	1	N/A	M03AP391334	M03AP454248
2	COVER - Front Outlet - 2 in. PV Clamp	1	N/A	M03AP454237	M03AP454249
2	COVER - Front Outlet - 2 in. ISS (APV-SP)	1	N/A	M03AP454238	M03AP454250
2	COVER - Front Outlet - 2 in. Tri-Clamp	1	N/A	M03AP454239	M03AP454072
2	COVER - Front Outlet - 2 in. Cherry-Burrell "I"	1	N/A	M03AP454240	M03AP454251
2	COVER - Front Outlet - 2 in. Butt Weld	1	N/A	M03AP454241	M03AP454252
2	COVER - D/D Front Outlet - 2 in. Th'd Bevel Seat	1	N/A	M03AP257457	N/A
2	COVER - D/D Front Outlet - 2 in. Th'd PV Seat	1	N/A	M03AP454084	N/A
2	COVER - D/D Front Outlet - 2 in. PV Clamp	1	N/A	M03AP454244	N/A
2	COVER - D/D Front Outlet - 2 in. ISS (APV-SP)	1	N/A	M03AP454245	N/A
2	COVER - D/D Front Outlet - 2 in. Tri-Clamp	1	N/A	M03AP430456	N/A
2	COVER - D/D Front Outlet - 2 in. Cherry-Burrell "I"	1	N/A	M03AP454246	N/A
2	COVER - D/D Front Outlet - 2 in. Butt Weld	1	N/A	M03AP454247	N/A

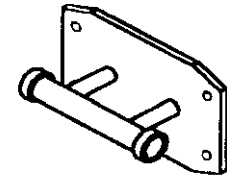

Deaerator/Degasser Cover

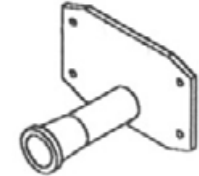

Front Outlet Cover



Front Outlet-Deaerator/Degasser Cover

### BODY OPTIONS

ITEM	DESCRIPTION	QTY.	PART NO.		
			R2RI	R3RI	R3HDRI
9	BODY - Rect Inlet - 1.5" Butt Weld	1	M03AP421976	N/A	N/A
9	BODY - Rect Inlet - 1.5" Bevel Seat	1	M03AP257522	N/A	N/A
9	BODY - Rect Inlet - 1.5" Th'd PV Seat	1	M03AP254282	N/A	N/A
9	BODY - Rect Inlet - 1.5" APC-PV Clamp Seat	1	M03AP254926	N/A	N/A
9	BODY - Rect Inlet - 1.5" ISS	1	M03AP342490	N/A	N/A
9	BODY - Rect Inlet - 1.5" Tri-Clamp	1	M03AP367979	N/A	N/A
9	BODY - Rect Inlet - 1.5" Cherry Burrell "I"	1	M03AP254927	N/A	N/A
9	BODY - Rect Inlet - 1.5" 150# Flange	1	M03AP254928	N/A	N/A
9	BODY - Rect Inlet - 2" Butt Weld	1	N/A	M03HP255239	M03AP452721
9	BODY - Rect Inlet - 2" Bevel Seat	1	N/A	M03AP177322	M03AP232932
9	BODY - Rect Inlet - 2" Th'd PV Seat	1	N/A	M03AP235689	M03AP316852
9	BODY - Rect Inlet - 2" APC-PV Clamp Seat	1	N/A	M03AP235690	M03AP418971
9	BODY - Rect Inlet - 2" ISS	1	N/A	M03AP235691	M03AP334691
9	BODY - Rect Inlet - 2" Tri-Clamp	1	N/A	M03AP235688	M03AP342519
9	BODY - Rect Inlet - 2" Cherry Burrell "I"	1	N/A	M03AP235693	M03AP452737
9	BODY - Rect Inlet - 2" 150# Flange	1	N/A	M03AP235694	M03AP454217
9	BODY - Rect Inlet - use with Front Outlet Cover	1	N/A	M03HP255887	M03AP261689

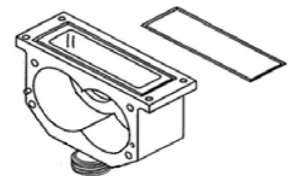

Standard Rectangular Inlet Body

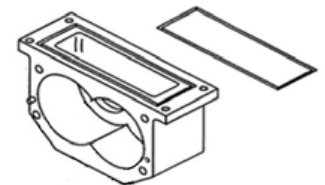

Rectangular Inlet Body with Front Outlet Cover

## MODELS R2RI, R3RI, R3HDRI

### GEARCASE OPTIONS

ITEM	DESCRIPTION	PART NUMBERS				
		QTY.	R1	R2	R3	R3HD
19	GEAR CASE & COVER ASSEMBLY - Std Mt	1	M03AP469372	M03AP469372	M03AP465980	M03AP465980
19	GEAR CASE & COVER ASSY- Top Feed - Pedestal M	1	M03AP180584	M03AP180584	M03AP469448	M03AP469448
19	GEAR CASE & COVER ASSEMBLY - WFS - Std Mt	1	M03AP454080	M03AP454080	M03AP454082	M03AP454082
19	GEAR CASE & COVER ASSY-Top Feed-Ped Mt-wfs	1	M03AP454081	M03AP454081	N/A	N/A
19	GEAR CASE & COVER ASSY-Top Feed-Floor Mount	1	N/A	N/A	M03AP255718	M03AP255718

### GEAR CASE ASSEMBLY - INCL SHAFTS - (Includes Items 9-29, excluding #12 & #25)

19A	GEAR CASE ASY - SIDE FEED - TOP SHAFT	-	M03AP454759	M03AP454696	M03AP454819	M03AP454686
19A	GEAR CASE ASY - SIDE FEED - BOTTOM SHAFT	-	M03AP454760	M03AP454697	M03AP454820	M03AP454687
19A	GEAR CASE ASY -TOP FEED - RH SHAFT-PED MT	-	M03AP454847	M03AP454843	M03AP454823	M03AP454690
19A	GEAR CASE ASY - TOP FEED - LH SHAFT-PED MT	-	M03AP454848	M03AP454844	M03AP454824	M03AP454691
19A	GEAR CASE ASY -TOP FEED - RH SHAFT-FLR MT	-	N/A	N/A	M03AP454827	M03AP454694
19A	GEAR CASE ASY - TOP FEED - LH SHAFT-FLR MT	-	N/A	N/A	M03AP454828	M03AP454695

(\*) Assembly includes items 32, 33 and 34

### GEARCASE ASSEMBLY OPTIONS - WATER FLUSH SEAL (Includes Items 9-29, excluding #12 & #25)

19A	GEAR CASE ASY - SIDE FEED - TOP SHAFT	-	M03AP454761	M03AP454716	M03AP454821	M03AP454688
19A	GEAR CASE ASY - SIDE FEED - BOTTOM SHAFT	-	M03AP454762	M03AP454717	M03AP454822	M03AP454689
19A	GEAR CASE ASY -TOP FEED - RH SHAFT-PED MT	-	M03AP454849	M03AP454845	M03AP454825	M03AP454692
19A	GEAR CASE ASY - TOP FEED - LH SHAFT-PED MT	-	M03AP454850	M03AP454846	M03AP454826	M03AP454693

(\*) Assembly includes items 32, 33 and 34

### GEARCASE & PLUG ASSY - (includes items 13,14,18, 21, 22, 23, 24 - does not include item 16 gasket)

19B	GEAR CASE & PLUG ASSEMBLY	1	M03WP469372	M03WP469372	M03WP465980	M03WP465980
33	SUPPORT POST - PEDESTAL MOUNT	-	M03HP180581	M03HP180581	M03HP177997	M03HP177997
34	SUPPORT BRACKET - PEDESTAL MOUNT	-	M03HP180582	M03HP180582	M03HP177733	M03HP177733
35	GASKET - SUPPORT POST	-	M549P133577	M549P133577	M549P133577	M549P133577

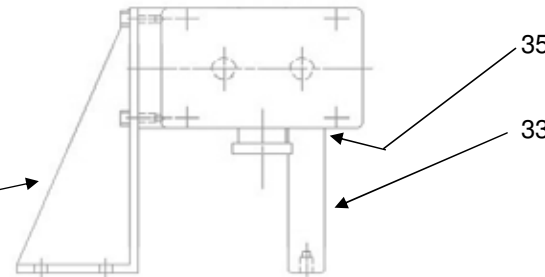
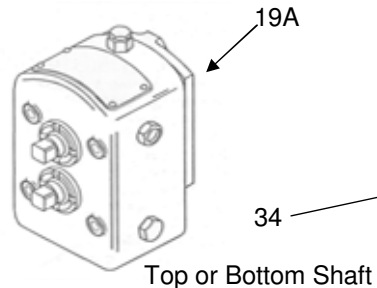
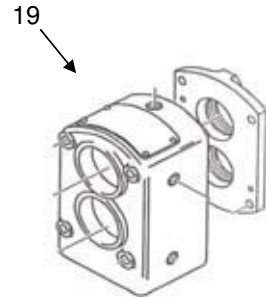

Top Feed - RH or LH shaft is determined when looking at pump from the front cover end. Support post, bracket and gasket (#33, 34, 35) is only included with gear case assemblies marked with an asterisk (\*).

# MODELS R4, AND R6

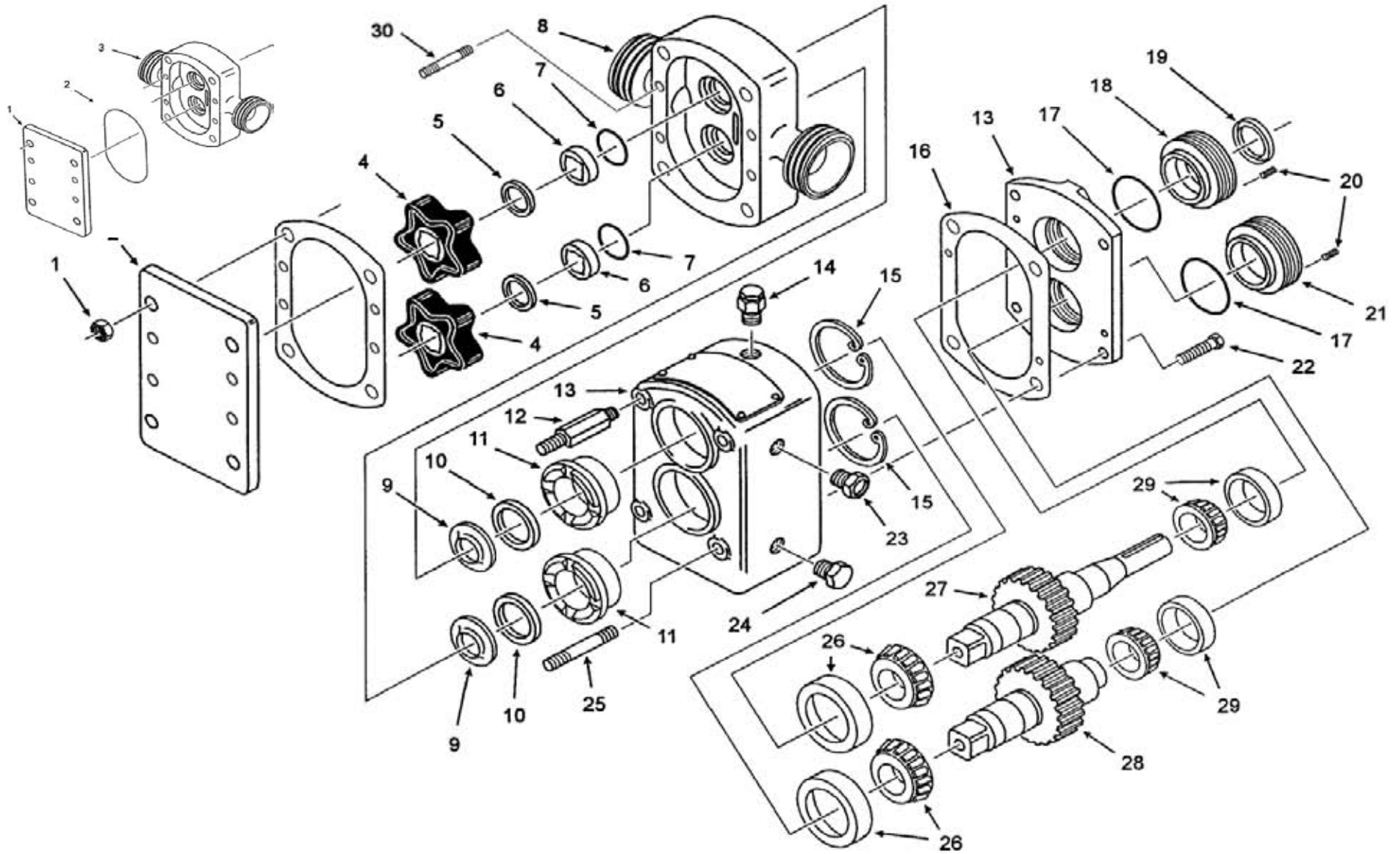

## MODELS R4, AND R6

ITEM	DESCRIPTION	PART NUMBERS		
		QTY.	R4	R6
1	NUT - Hex (Stainless Steel)	8	M523V006529	M523V006529
	NUT - Wing (optional)	8	M727P397882	M727P397882
2	COVER - Standard Front Cover	1	M03HP133615	M03HP133615
	COVER - Vented cover (optional) - see options	1	see vented cover section	
	COVER - Front - (Option: Deaerator/Degasser)	1	see optional cover section	
3	GASKET - Cover (Paper) (Sold in pks of 100)	1	M541P133610	M541P133610
4	ROTORs - 5 Lobe	2	See Rotors	See Rotors
5	SEAL - Shaft (Sold in pks of 10pcs)	2	See Shaft Seals	See Shaft Seals
6	BEARING - Seal (Stainless Steel)	2	M03HP137734	M03HP137734
7	O-RING - Pump Seal (Sold in pks of 10pcs)	2	M543S131405	M543S131405
8	BODY	1	see body section	
9	RING -Seal (Sold in pks of 5pcs)	2	M03HP137738	M03HP137738
10	SEAL - Front Oil	2	M543SK609	M543SK609
11	PLUG - Locating	2	M03HP133603	M03HP133603
	PLUG - Locating - (Option: Water flush seal)	2	M03HP218225	M03HP218225
12	STUD HEX - standard front cover	1	M03HP137764	M03HP137765
13	GEAR CASE ASSEMBLY	1	see gear case section	
14	PLUG - vent (breather)	1	M569P454192	M569P454192
15	RING - Retaining	2	M689P138716	M689P138716
16	GASKET - Gear Case	1	M549P137756	M549P137756
17	O-RING - Rear Bearing Seal (Sold in pks of 10pcs)	2	M543S131413	M543S131413
18	NUT - Bearing Adjustment & Seal Retainer	1	M03HP133578	M03HP133578
19	SEAL - Rear Oil	1	M543SK608	M543SK608
20	SCREW - Set	2	M522V006970	M522V006970
21	NUT - Bearing Adjustment	1	M03HP133580	M03HP133580
22	SCREW - HEX HD	6	M522V006804	M522V006804
23	SIGHT GLASS	1	M569P454191	M569P454191
24	OIL PLUG	2	M569P454190	M69P454190
25	STUD ROUND - standard front cover	3	M03HP133604	M03HP133626
26	BEARING - Front - Tapered Roller	2	M621S4158B	M621S4158B
27	SHAFT & GEAR ASSEMBLY - Long	1	M03AP137763	M03AP137767
28	SHAFT & GEAR ASSEMBLY - Short	1	M03AP137719	M03AP137746
29	BEARING - Rear - Tapered Roller	2	M621S4158F	M621S4158F
30	STUD - Short Round - std cover	4	M03HP167185	M03HP167185
	STUD - Short -vented cover option	-	see vented cover section	

## MODELS R4, AND R6

### BODY OPTIONS

ITEM	DESCRIPTION	PART NUMBERS		
		QTY.	R4	R6
8	BODY- 2" Butt Weld	1	M03HP171284	N/A
	BODY - 2" Bevel Seat	1	M03AP133622	N/A
	BODY - 2" Th'd PV Seat	1	M03AP171353	N/A
	BODY - 2" PV (APC) Clamp	1	M03AP171355	N/A
	BODY - 2" ISS (APV-SP) Clamp	1	M03AP171346	N/A
	BODY - 2" Tri-Clamp	1	M03AP171356	N/A
	BODY - 2" Cherry Burrell "I"	1	M03AP171349	N/A
	BODY - 2" Flange	1	M03AP200266	N/A
8	BODY- 2.5" Butt Weld	1	N/A	M03HP171285
	BODY - 2.5" Bevel Seat	1	N/A	M03AP133636
	BODY - 2.5" Th'd PV Seat	1	N/A	M03AP171375
	BODY - 2.5" PV (APC) Clamp	1	N/A	M03AP171377
	BODY - 2.5" ISS (APV-SP) Clamp	1	N/A	-
	BODY - 2.5" Tri-Clamp	1	N/A	M03AP171378
	BODY - 2.5" Cherry Burrell "I"	1	N/A	M03AP171371
	BODY - 2.5" - Flange	1	N/A	-
8	BODY- 3" Butt Weld	1	M03HP189668	M03HP171286
	BODY - 3" Bevel Seat	1	M03AP189850	M03AP153857
	BODY - 3" Th'd PV Seat	1	M03AP189858	M03AP171397
	BODY - 3" PV (APC) Clamp	1	M03AP189860	M03AP171399
	BODY - 3" ISS (APV-SP) Clamp	1	M03AP189851	M03AP171390
	BODY - 3" Tri-Clamp	1	M03AP189861	M03AP171400
	BODY - 3" Cherry Burrell "I"	1	M03AP189854	M03AP171393
	BODY - 3" - Flange	1	M03AP219166	M03AP209351
	BODY - 3" - Male Pipe Thread	1	N/A	M03AP171389

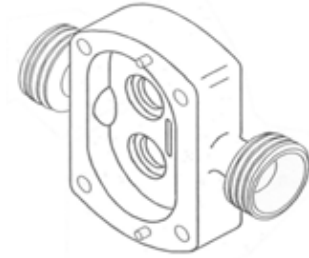

### COVER OPTIONS

2	COVER - Deaerator/Degasser	1	M03AP246945	M03AP246945
2	COVER - Vented cover (optional) - see options	1	see vented cover section	
33	PLUG - DEAERATOR/DEGASSER COVER	2	M03HP229670	M03HP229670

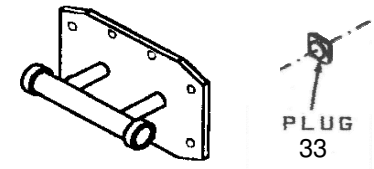

Deaerator/Degasser  
Cover

## MODELS R4, AND R6

### GEAR CASE OPTIONS

ITEM	DESCRIPTION	PART NUMBERS		
		QTY.	R4	R6
13	GEAR CASE & COVER - SIDE FEED	1	M03AP144593	M03AP144593
13	GEAR CASE & COVER - TOP FEED	1	M03AP254038	M03AP254038

### GEAR CASE & PLUG ASSEMBLY includes items #13,14,18,21,22,23,24)

13B	GEAR CASE & PLUG ASSEMBLY - SIDE FEED (STD)	1	M03WP144593	M03WP144593
13B	GEAR CASE & PLUG ASSEMBLY - TOP FEED	1	M03WP162892	M03WP162892

### GEAR CASE ASSEMBLY - INCL SHAFTS - (Includes Items 9-29, excluding #12 & #25)

13A	GEAR CASE ASY - SIDE FEED - TOP SHAFT	1	M03AP454807	M03AP454536
13A	GEAR CASE ASY - SIDE FEED - BOTTOM SHAFT	1	M03AP454808	M03AP454537
13A	GEAR CASE ASY - TOP FEED - RH SHAFT-PED MT (*)	1	M03AP454811	M03AP454540
13A	GEAR CASE ASY - TOP FEED - LH SHAFT-PED MT (*)	1	M03AP454812	M03AP454541
13A	GEAR CASE ASY - TOP FEED - RH SHAFT-FLOOR MT	1	M03AP454815	M03AP454544
13A	GEAR CASE ASY - TOP FEED - LH SHAFT-FLOOR MT	1	M03AP454816	M03AP454545
13A	GEAR CASE ASY - TOP FEED - RH SHAFT-CEILING MT	1	M03AP454817	M03AP454546
13A	GEAR CASE ASY - TOP FEED - LH SHAFT-CEILING MT	1	M03AP454818	M03AP454547

(\*) These items include pedestal (#31)

### GEAR CASE ASSEMBLY OPTIONS - WATER FLUSH SEAL (Includes Items 9-29, excluding #12 & #25)

13A	GEAR CASE ASY - SIDE FEED - TOP SHAFT - WFS	1	M03AP454809	M03AP454538
13A	GEAR CASE ASY - SIDE FEED - BOTTOM SHAFT - WFS	1	M03AP454810	M03AP454539
13A	GEAR CASE ASY - TOP FEED - RH SHAFT-PED MT - WFS (*)	1	M03AP454813	M03AP454542
13A	GEAR CASE ASY - TOP FEED - LH SHAFT-PED MT - WFS (*)	1	M03AP454814	M03AP454543

(\*) These items include pedestal (#31)

31	SUPPORT POST - PEDESTAL MOUNT	1	M03HP162866	M03HP162866
----	-------------------------------	---	-------------	-------------

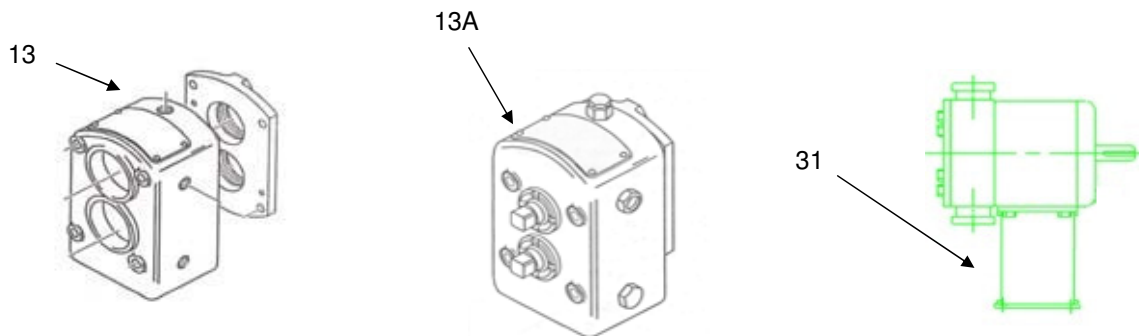

Top or Bottom Shaft

Top Feed - RH or LH shaft is determined when looking at pump from the front cover end. Pedestal (#31) is only included with gear case assemblies marked with an asterisk (\*).

# MODELS R4RI AND R6RI

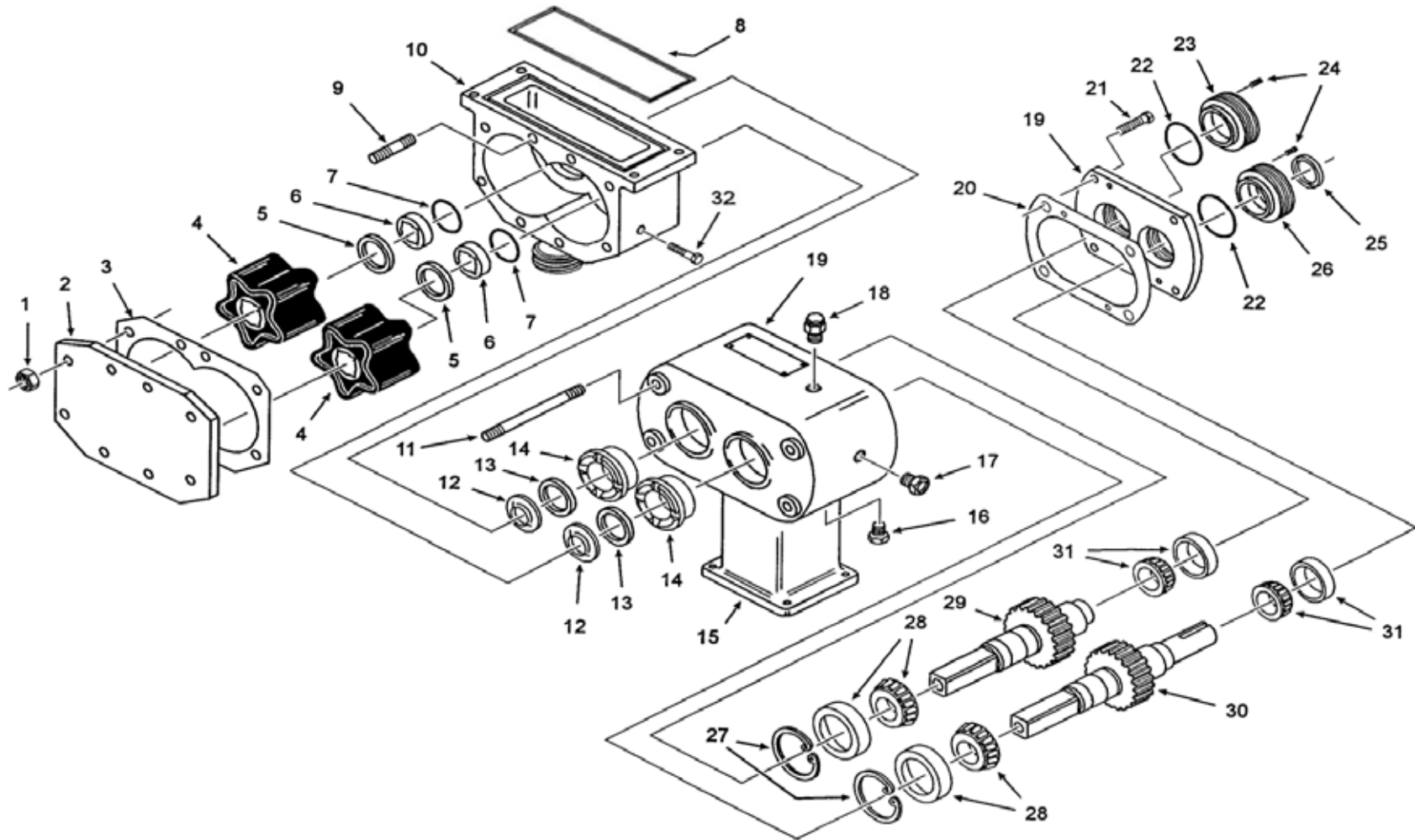

## MODELS R4RI AND R6RI

ITEM	DESCRIPTION	QTY.	PART NO.	
			R4RI	R6RI
1	NUT - Hex (Stainless Steel)	8	M523V006529	M523V006529
	NUT - Wing	8	M727P397882	M727P397882
2	COVER - Rectangular Inlet - STD FLAT COVER	1	M3HP133615	M03HP133615
	COVER - OPTIONS - SEE COVER SECTION	1	SEE COVER SECTION	
3	GASKET - Cover (Paper) Standard (SOLD PKS OF 100PCS)	1	M541P133610	M541P133610
4	ROTORS - 5 Lobe	2	See Rotors	See Rotors
5	SEAL - Shaft	2	See Shaft Seals	See Shaft Seals
6	BEARING - Seal, SS, Standard	2	M03HP137734	M03HP137734
7	O-RING - Pump Seal (SODL PKS OF 10PCS)	2	M543S131405	M543S131405
8	GASKET - Rectangular Inlet Flange	1	M03HP334134	M03HP334136
9	STUD - Short Round (shown - used with 1 hex short stud)	3	M03HP167185	M03HP167185
	STUD - Short Hex (not shown, used with 3 round short studs)	1	M03HP167793	M03HP167793
10	BODY - SEE BODY SECTION	1	SEE BODY SECTION	
11	STUD - Long Round	4	M03HP133604	M03HP133626
12	RING - Seal	2	M03HP137738	M03HP137738
13	SEAL - Front Oil	2	M543SK609	M543SK609
14	PLUG - Locating	2	M03HP133603	M03HP133603
15	PEDESTAL - support post	1	M03HP162866	M03HP162866
16	OIL PLUG	1	M569P454190	M569P454190
17	SIGHT GLASS	1	M569P454191	M569P454191
18	PLUG - vent (breather)	1	M569P454192	M569P454192
19	GEAR CASE ASSEMBLY	1	see Gear case section	
20	GASKET - Gear Case	1	M549P137756	M549P137756
21	SCREW	6	M522V006804	M522V006804
22	O-RING - Rear Bearing Seal (SOLD PKS OF 10PCS)	2	M543S131413	M543S131413
23	NUT - Bearing Adjusting	1	M03HP133580	M03HP133580
24	SCREW - Set, Gear Case	2	M522V006970	M522V006970
25	SEAL - Rear oil	1	M543SK608	M543SK608
26	NUT - Bearing Adjusting & Seal Retainer	1	M03HP133578	M03HP133578
27	RING - Retaining	1	M689P138716	M689P138716
28	BEARING - Gear Case - Front (Tapered Roller)	2	M621S4158B	M621S4158B
29	SHAFT & GEAR ASSEMBLY - Short	1	M03AP137719	M03AP137746
30	SHAFT & GEAR ASSEMBLY - Long	1	M03AP137763	M03AP137767
31	BEARING - Gear Case - Rear (Tapered Roller)	2	M621S4158F	M621S4158F
32	SCREW - RI Body	2	M521V006688	M521V006688



## MODELS R4RI AND R6RI

### COVER OPTIONS

2	COVER - Standard flat cover for rectangular inlet body	1	M03HP133615	M03HP133615
2A	COVER - Deaerator/Degasser for rectangular inlet body	1	M03AP246945	M03AP246945
-	COVER - VENTED COVER - SEE VENTED COVER OPTION	1	M03AP246945	M03AP246945
33	PLUG - DEAERATOR/DEGASSER COVER (see below)	2	M03HP229670	M03HP229670

2B	COVER - Front Outlet - 3" Butt Weld	1	M03AP442014	M03AP442014
2B	COVER - Front Outlet - 3" Th'd Bevel Seat	1	M03AP255180	M03AP255180
2B	COVER - Front Outlet - 3" Th'd PV Seat	1	M03AP454281	M03AP454281
2B	COVER - Front Outlet - 3" PV (APC) Clamp	1	M03AP267420	M03AP267420
2B	COVER - Front Outlet - 3" ISS (APV - SP)	1	M03AP454282	M03AP454282
2B	COVER - Front Outlet - 3" Tri-Clamp	1	M03AP447698	M03AP447698
2B	COVER - Front Outlet - 3" Cherry-Burrell "I"	1	M03AP291755	M03AP291755

2C	COVER - Deaerator/Degasser Front Outlet - 3" Butt Weld	1	M03AP830406	M03AP830406
2C	COVER - Deaerator/Degasser Front Outlet - 3" Th'd Bevel Seat	1	M03AP830413	M03AP830413
2C	COVER - Deaerator/Degasser Front Outlet - 3" Th'd PV Seat	1	M03AP830412	M03AP830412
2C	COVER - Deaerator/Degasser Front Outlet - 3" PV (APC) Clamp	1	M03AP830411	M03AP830411
2C	COVER - Deaerator/Degasser Front Outlet - 3" ISS (APV-SP)	1	M03AP830410	M03AP830410
2C	COVER - Deaerator/Degasser Front Outlet - 3" Tri-Clamp	1	M03AP830409	M03AP830409
2C	COVER - Deaerator/Degasser Front Outlet - 3" Cherry-Burrell "I"	1	M03AP830407	M03AP830407
33	PLUG - DEAERATOR/DEGASSER COVER (see below)	2	M03HP229670	M03HP229670

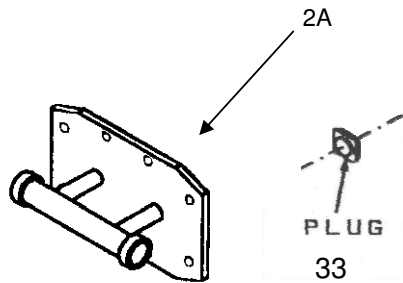

Deaerator/Degasser  
Cover

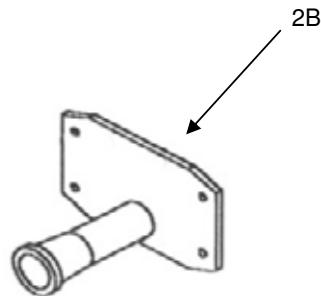

Front Outlet Cover  
Use with body 10A on next  
page.

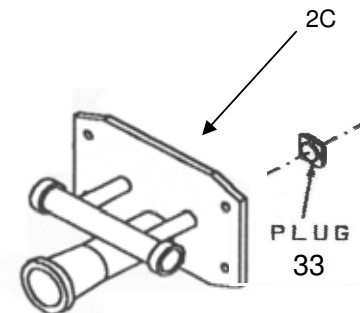

Front Outlet-Deaerator/ Degasser Cover  
Use with body 10A on next page.

## MODELS R4RI AND R6RI

### BODY OPTIONS

10	BODY RI - 3" Butt Weld	1	M03HP237170	M3HP232176
10	BODY RI - 3" Bevel Seat	1	M03AP239461	M03AP171209
10	BODY RI - 3" Th'd PV Seat	1	M03AP239469	M03AP232992
10	BODY RI - 3" PV Clamp	1	M03AP239471	M03AP232994
10	BODY RI - 3" ISS (APV-SP) Clamp	1	M03AP239462	M03AP232985
10	BODY RI - 3" Tri-Clamp	1	M03AP239472	M3AP232995
10	BODY RI - 3" Cherry Burrell "I"	1	M03AP239465	M03AP232988
10	BODY RI - 3" - 150# Flange	1	M03AP239475	M3AP342777
10A	BODY RI - used with Front Outlet Cover Options (no outlet)	1	M03HP246185	M03HP254084

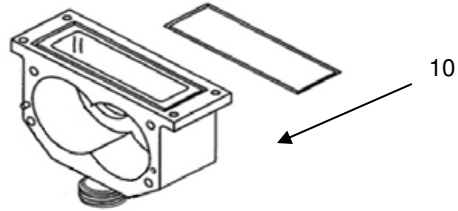

# 10 - Standard  
Rectangular Inlet Body

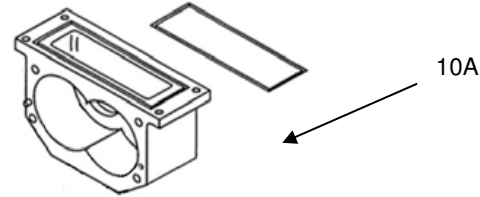

# 10A - Rectangular Inlet Body  
with Front Outlet Cover

## MODELS R4RI AND R6RI

### GEAR CASE OPTIONS

ITEM	DESCRIPTION	PART NUMBERS		
		QTY.	R4	R6
19	GEAR CASE & COVER - SIDE FEED (STANDARD)	1	M03AP144593	M03AP144593
19	GEAR CASE & COVER - TOP FEED	1	M03AP254038	M03AP254038

### GEAR CASE & PLUG ASSEMBLY (Includes items #16, 17, 18, 19, 21, 23, 26)

19B	GEAR CASE & PLUG ASSEMBLY - SIDE FEED (STD)	1	M03WP144593	M03WP144593
19B	GEAR CASE & PLUG ASSEMBLY - TOP FEED	1	M03WP162892	M03WP162892

### GEAR CASE ASSEMBLY - INCL SHAFTS - (Includes Items 12-31, excluding #15) (see note below)

19A	GEAR CASE ASY - SIDE FEED - TOP SHAFT	-	M03AP454807	M03AP454536
19A	GEAR CASE ASY - SIDE FEED - BOTTOM SHAFT	-	M03AP454808	M03AP454537
19A	GEAR CASE ASY - TOP FEED - RH SHAFT-PED MT (*)	-	M03AP454811	M03AP454540
19A	GEAR CASE ASY - TOP FEED - LH SHAFT-PED MT (*)	-	M03AP454812	M03AP454541
19A	GEAR CASE ASY - TOP FEED - RH SHAFT-FLOOR MT	-	M03AP454815	M03AP454544
19A	GEAR CASE ASY - TOP FEED - LH SHAFT-FLOOR MT	-	M03AP454816	M03AP454545
19A	GEAR CASE ASY - TOP FEED - RH SHAFT-CEILING MT	-	M03AP454817	M03AP454546
19A	GEAR CASE ASY - TOP FEED - LH SHAFT-CEILING MT	-	M03AP454818	M03AP454547

(\*) These items include pedestal (#50)

### GEAR CASE ASSEMBLY - WATER FLUSH SEAL (Includes Items 12-31, excluding #15) (see note below)

19A	GEAR CASE ASY - SIDE FEED - TOP SHAFT - WFS	-	M03AP454809	M03AP454538
19A	GEAR CASE ASY - SIDE FEED - BOTTOM SHAFT - WFS	-	M03AP454810	M03AP454539
19A	GEAR CASE ASY - TOP FEED - RH SHAFT-PED MT - WFS (*)	-	M03AP454813	M03AP454542
19A	GEAR CASE ASY - TOP FEED - LH SHAFT-PED MT - WFS (*)	-	M03AP454814	M03AP454543

(\*) These items include pedestal (#50)

50	SUPPORT POST - PEDESTAL MOUNT	-	M03HP162866	M03HP162866
----	-------------------------------	---	-------------	-------------

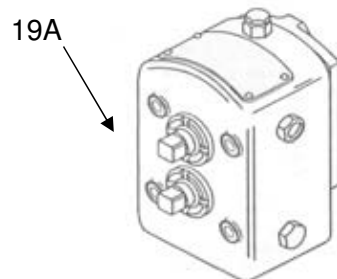
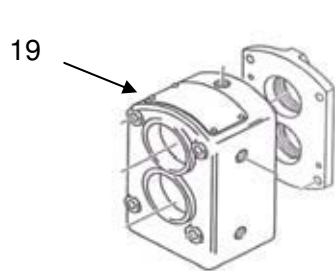

Top or Bottom Shaft

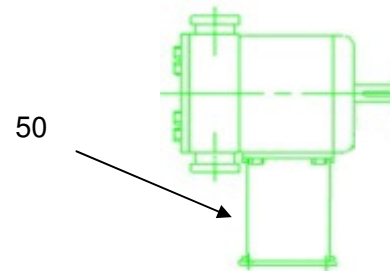

80

Top Feed - RH or LH shaft is determined when looking at pump from the front cover end. Pedestal (#50) is only included with gear case assemblies marked with an asterisk (\*).

# MODELS R4HD, R6HD

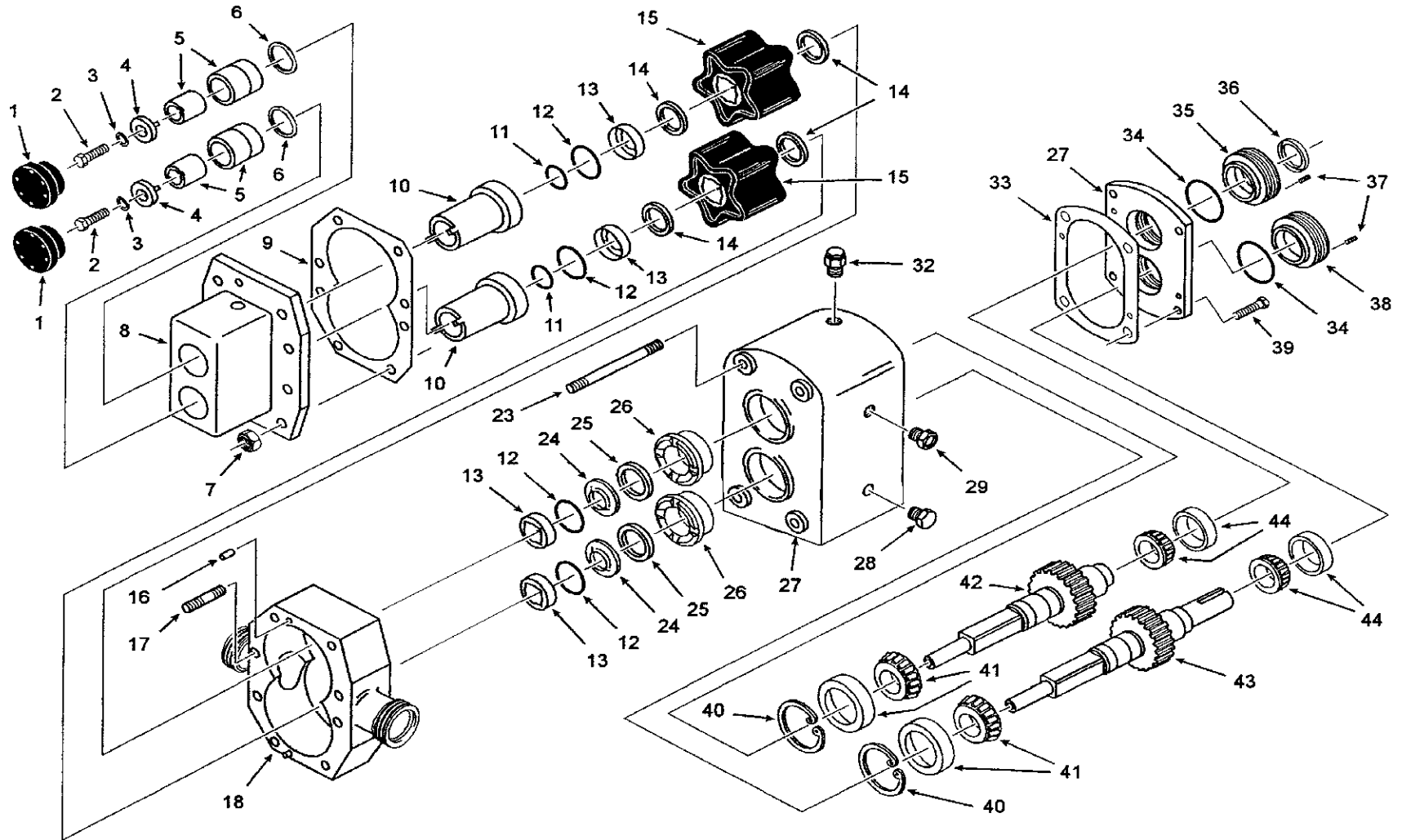

## MODELS R4HD, R6HD

ITEM	DESCRIPTION	QTY.	PART NO.	
			R4HD	R6HD
1	CAP - Bearing End, Heavy-Duty	2	M03HP225266	M03HP225266
2	SCREW	2	M521P229095	M521P229095
3	WASHER	2	M523V008819	M523V008819
4	PLATE & PIN (RETAINING WASHER)	2	M03AP225267	M03AP225267
5	BEARING ASSEMBLY - Outboard Complete (INCL 5A & 5B below)	2	M03AP232733	M03AP232733
5A	Bearing - inner race	-	M03HP225661	M03HP225661
5B	Bearing - outer race	-	M621S8184B	M621S8184B
6	RING - Retainer	2	M03HP225033	M03HP225033
7	NUT - Hex (Stainless Steel)	8	M523V006529	M523V006529
	NUT - Wing	8	M727P397882	M727P397882
8	COVER - HEAVY DUTY - (includes # 5 and #6 above)	1	See Front Covers	
9	GASKET - Cover (Paper) Heavy-Duty (sold in boxes of 100)	1	M541P171854	M541P171854
10	CARTRIDGE - Front Seal & Spacer HD Seal (standard)	2	M03HP280219	M03HP280219
	CARTRIDGE - Front Seal & Spacer WFS	2	M03HP257717	M03HP257717
	CARTRIDGE - Front Seal & Spacer DEARATOR/DEGASSER	2	M03HP232854	M03HP232854
11	O-RING (Sold in pks of 10pcs)	2	M543S131402	M543S131402
12	O-RING - Pump Seal (Sold in pks of 10pcs)	4	M543S131405	M543S131405
13	BEARING - Seal (Stainless Steel)	4	M03HP137734	M03HP137734
14	SEAL - Shaft (Sold in pks of 10pcs)	4	See Shaft Seals	
15	ROTORs - 5 Lobe	2	See Rotors	
16	PIN - Locating	2	M525S1670G	M525S1670G
17	STUD - Short Round	4	M03HP167185	M03HP167185
18	BODY - Heavy Duty Pump	1	see Body section	
23	STUD - Long Round (3 round studs and 1 hex stud per pump)	3	M03HP133604	M03HP133626
	STUD - Long Hex (3 round studs and 1 hex stud per pump)	1	M03HP228959	M03HP233789
24	RING - Seal (Sold in pks of 5pcs)	2	M03HP137738	M03HP137738
25	SEAL - Front Oil	2	M543SK609	M543SK609
26	PLUG - Locating	2	M03HP133603	M03HP133603
	PLUG - Locating, WFS	2	M03HP218225	M03HP218225
27	GEAR CASE ASSEMBLY --see Gearcase section	1	see gearcase section	
28	OIL PLUG	2	M569P454190	M569P454190
29	SIGHT GLASS	1	M569P454191	M569P454191
32	BREATHER/OIL FILLER	1	M569P454192	M569P454192

## MODELS R4HD, R6HD

ITEM	DESCRIPTION	QTY.	PART NO.	
			R4HD	R6HD
33	GASKET - Gear Case	1	M549P137756	M549P137756
34	O-RING - Bearing Seal - Heavy Duty (Sold in pks of 5pcs)	2	M543S131422	M543S131422
35	NUT - Bearing Adjustment - 2-1/4 SHAFT	1	M03HP255805	M03HP255805
36	SEAL - Real Oil	1	M543SK609	M543SK609
37	SCREW - Set	4	M522V006970	M522V006970
38	NUT - Bearing Adjustment & Seal Retainer - 2-1/4 SHAFT	1	M03HP255804	M03HP255804
39	SCREW	6	M522V006804	M522V006804
40	RING - Retaining	2	M689P138716	M689P138716
41	BEARING - Front - Tapered Roller	2	M621S4158B	M621S4158B
42	SHAFT & GEAR ASSEMBLY - Short -2-1/4 SHAFT	1	M03AP262758	M03AP255811
42	SHAFT & GEAR ASSEMBLY - Short - 1-3/8" SHAFT *	1	M03AP228223	M03AP232749
43	SHAFT & GEAR ASSEMBLY - Long - 2-1/4 SHAFT	1	M03AP262756	M03AP255810
43	SHAFT & GEAR ASSEMBLY - Long - 1-3/8" SHAFT *		M03AP228224	M03AP232750
44	BEARING - Rear - Tapered Roller	2	M621S4158B	M621S4158B

(\*) These part numbers apply for gearcases with 1-3/8" input shaft on some older models

Please provide serial number when ordering parts for these models

(\*)

(\*)

### COVER OPTIONS

ITEM	DESCRIPTION	QTY.	PART NO.	
			R4HD	R6HD
8	COVER - HEAVY DUTY - STANDARD (includes # 5 and #6 above)	1	M03AP185437	M03AP185437
8	COVER-HD-WATER FLUSH SEAL (includes # 5 and #6 above)	1	M03AP257405	M03AP257405
8	COVER - HD - Deaerator/degasser (includes # 5 and #6 above)	1	M03AP250555	M03AP250555

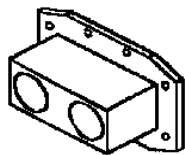

STD HEAVY DUTY COVER

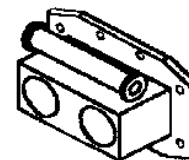

HEAVY DUTY COVER WITH  
DEAERATOR/DEGASSER

## MODELS R4HD, R6HD

### BODY OPTIONS

ITEM	DESCRIPTION	QTY.	PART NO.	
			R4HD	R6HD
18	BODY HD - 2" Butt Weld	1	M03AP452722	N/A
18	BODY HD - 2" Bevel Seat	1	M03AP229050	N/A
18	BODY HD - 2" Th'd PV Seat	1	M03AP229058	N/A
18	BODY HD - 2" APC-PV Clamp	1	M03AP229060	N/A
18	BODY HD - 2" ISS (APV-SP) Clamp	1	M03AP229051	N/A
18	BODY HD - 2" Tri-Clamp	1	M03AP229061	N/A
18	BODY HD - 2" Cherry Burrell "I"	1	M03AP229054	N/A
18	BODY HD - 2" Flange	1	M03AP229063	N/A
18	BODY HD - 2-1/2" Bevel Seat	1	N/A	M03AP180920
18	BODY HD - 3" Butt Weld	1	M03AP228206	M03AP221433
18	BODY HD - 3" Bevel Seat	1	M03AP228193	M03AP180921
18	BODY HD - 3" Th'd PV Seat	1	M03AP228201	M03AP221429
18	BODY HD - 3" APC-PV Clamp	1	M03AP228203	M03AP221431
18	BODY HD - 3" ISS (APV-SP) Clamp	1	M03AP228194	M03AP221422
18	BODY HD - 3" Tri-Clamp	1	M03AP228204	M03AP221432
18	BODY HD - 3" Cherry Burrell "I"	1	M03AP228197	M03AP221425
18	BODY HD - 3" - Flange	1	M03AP229077	M03AP221434

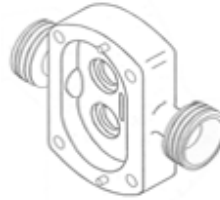

## MODELS R4HD, R6HD

### GEARCASE OPTIONS

ITEM	DESCRIPTION	QTY.	PART NO.	
			R4HD	R6HD
27	GEAR CASE & COVER ASSEMBLY	1	M03AP262754	M03AP262754
27	GEAR CASE & COVER ASSY -TF-Ped/floor mount	1	M03AP280214	M03AP280214

### GEAR CASE & PLUG ASSEMBLY - (Includes Items 27-29, 32, 33, 35, 38, 39)

27B	GEAR CASE & PLUG ASSEMBLY (#13, 18, 21)TOP FEED	1	M03WP262754	M03WP262754
27B	GEAR CASE & PLUG ASSY - TF-PED/FLR MT	1	M03WP280214	M03WP280214

### GEAR CASE ASSEMBLY - INCL SHAFTS - (Includes Items 24-29, 32-44)

27A	GEAR CASE ASY - TOP SHAFT	1	M03AP454789	M03AP454518
27A	GEAR CASE ASY - BOTTOM SHAFT	1	M03AP454790	M03AP454519
27A	GEAR CASE ASY -TOP FEED - RH SHAFT-PED MT (*)	1	M03AP454793	M03AP454522
27A	GEAR CASE ASY - TOP FEED - LH SHAFT-PED MT (*)	1	M03AP454794	M03AP454523
27A	GEAR CASE ASY -TOP FEED - RH SHAFT-FLR MT	1	M03AP454797	M03AP454526
27A	GEAR CASE ASY - TOP FEED - LH SHAFT-FLR MT	1	M03AP454798	M03AP454527

(\*) These items include support post (#50) and support bracket (#51)

### GEARCASE ASSEMBLY OPTIONS - WATER FLUSH SEAL (Includes Items 24-29, 32-44)

27A	GEAR CASE ASY - TOP SHAFT	1	M03AP454791	M03AP454520
27A	GEAR CASE ASY - BOTTOM SHAFT	1	M03AP454792	M03AP454521
27A	GEAR CASE ASY -TOP FEED - RH SHAFT-PED MT (*)	1	M03AP454795	M03AP454524
27A	GEAR CASE ASY - TOP FEED - LH SHAFT-PED MT (*)	1	M03AP454796	M03AP454525

(\*) These items include support post (#50) and support bracket (#51)

50	SUPPORT POST - PEDESTAL MOUNT	1	M03HP162866	M03HP162866
51	SUPPORT BRACKET - PEDESTAL MOUNT	1	M03HP177674	M03HP177674

**NOTE:** All gearcases listed on this page have 2-1/4" drive shaft.

Some older models have 1-3/8" drive shaft. Call for part number (serial number required.).

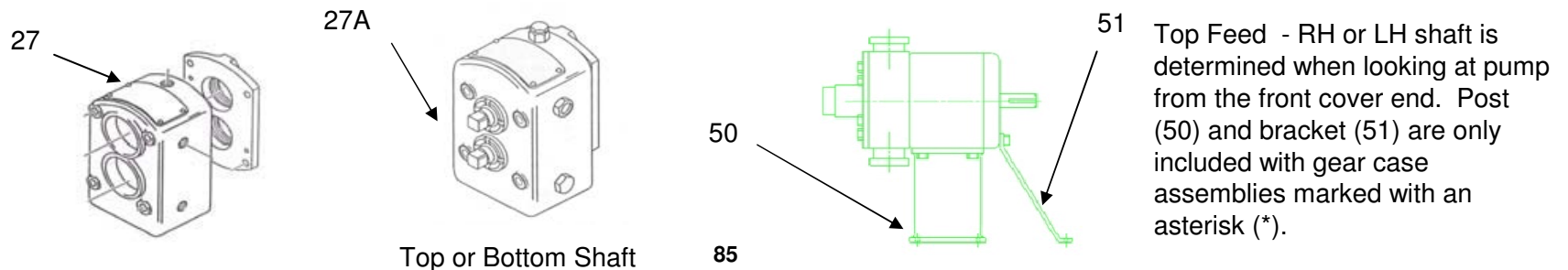



MODELS R4HDRI, R6HDRI

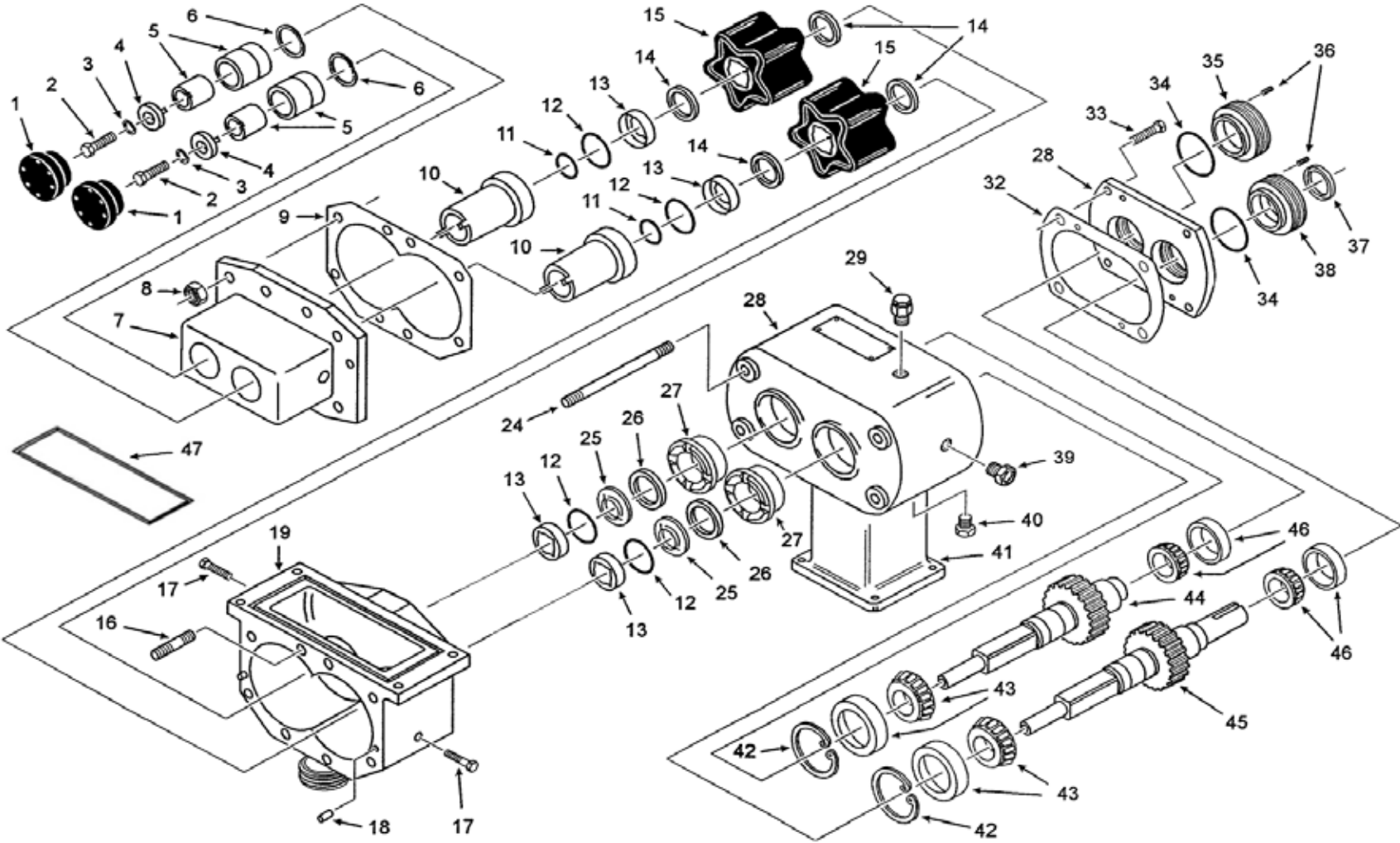

## MODELS R4HDRI, R6HDRI

ITEM	DESCRIPTION	QTY.	PART NO.	
			R4HDRI	R6HDRI
1	CAP - Bearing End, Heavy Duty	2	M03HP225266	M03HP225266
2	BOLT	2	M521P229095	M521P229095
3	WASHER	2	M523V008819	M523V008819
4	PLATE & PIN - Bearing - Retainer, HD	2	M03AP225267	M03AP225267
5	BEARING Assembly - Outboard Complete	2	M03AP232733	M03AP232733
5A	Bearing - inner race	-	M03HP225661	M03HP225661
5B	Bearing - outer race	-	M621S8184B	M621S8184B
6	RING - Retainer	2	M03HP225033	M03HP225033
7	COVER - HEAVY DUTY - see Covers	1	See Covers	See Covers
8	NUT - Hex (Stainless Steel)	8	M523V006529	M523V006529
	NUT - Wing	8	M727P397882	M727P397882
9	GASKET - Cover (Paper) Heavy-Duty (sold in boxes of 100)	1	M541P171854	M541P171854
10	CARTRIDGE - Front Seal & Spacer HD Seal (standard)	2	M03HP280219	M03HP280219
	CARTRIDGE - Front Seal & Spacer WFS	2	M03HP257717	M03HP257717
	CARTRIDGE - Front Seal & Spacer DEARATOR/DEGASSER	2	M03HP232854	M03HP232854
11	O-RING - Bearing Seal, Heavy-Duty (Sold in pks of 10pcs)	2	M543S131402	M543S131402
12	O-RING - Pump Seal (Sold in pks of 10pcs)	4	M543S131405	M543S131405
13	BEARING - Seal, SS, Standard	4	M03HP137734	M03HP137734
14	SEAL - Shaft (Sold in pks of 10pcs)	2	See Shaft Seals	See Shaft Seals
15	ROTORS - 5 Lobe	2	See Rotors	See Rotors
16	STUD - Short Round	4	M03HP167185	M03HP167185
17	SCREW	2	M521V006688	M521V006688
18	PIN - Locating	2	M525S1670G	M525S1670G
19	BODY - see body section	1	See Body Section	See Body Section
24	STUD - Long Round	4	M03HP133604	M03HP133626
25	RING - Seal (Sold in pks of 10pcs)	2	M03HP137738	M03HP137738
26	SEAL - Front Oil	2	M543SK609	M543SK609
27	PLUG - Locating	2	M03HP133603	M03HP133603
	PLUG - Locating, WFS	2	M03HP218225	M03HP218225
28	GEAR CASE ASSEMBLY --see Gearcase section	1	See Gearcases	See Gearcases
29	BREATHER/OIL FILLER	1	M569P454192	M569P454192
32	GASKET - Gear Case	1	M549P137756	M549P137756
33	SCREW	6	M522V006804	M522V006804
34	O-RING - Bearing Seal 2-1/4" SHAFT (Sold in pks of 5pcs)	2	M543S131422	M543S131422
	O-RING - Bearing Seal 1-3/8" SHAFT (*) (Sold in pks of 10pcs)	2	M543S131413	M543S131413 (*)
35	NUT - Bearing Adjustment - 2-1/4" SHAFT	1	M03HP255805	M03HP255805
	NUT - Bearing Adjustment - 1-3/8" SHAFT (*)	1	M03HP133580	M03HP133580 (*)

## MODELS R4HDRI, R6HDRI

ITEM	DESCRIPTION	QTY.	PART NO.	
			R4HDRI	R6HDRI
36	SCREW	4	M522V006970	M522V006970
37	SEAL - Real Oil 2-1/4" SHAFT	1	M543SK609	M543SK609
	SEAL - Real Oil 1-3/8" SHAFT (*)	1	<i>M543SK608</i>	<i>M543SK608</i>
38	NUT - Bearing Adjustment & Seal Retainer - 2-1/4" SHAFT	1	M03HP255804	M03HP255804
	NUT - Bearing Adjustment & Seal Retainer - 1-3/8" SHAFT (*)	1	<i>M03HP133578</i>	<i>M03HP133578</i>
39	SIGHT GLASS	1	M569P454191	M569P454191
40	OIL PLUG	1	M569P454190	M569P454190
41	PEDESTAL	1	M03HP162866	M03HP162866
42	RING - Retaining	1	M689P138716	M689P138716
43	BEARING - Gear Case - Front (Tapered Roller)	2	M621S4158B	M621S4158B
44	SHAFT & GEAR ASSEMBLY - Short -2-1/4" SHAFT	1	M03AP262758	M03AP255811
44	SHAFT & GEAR ASSEMBLY - Short - 1-3/8" SHAFT (*)	1	<i>M03AP228223</i>	<i>M03AP232749</i>
45	SHAFT & GEAR ASSEMBLY - Long - 2-1/4" SHAFT	1	M03AP262756	M03AP255810
45	SHAFT & GEAR ASSEMBLY - Long - 1-3/8" SHAFT (*)	1	<i>M03AP228224</i>	<i>M03AP232750</i>
46	BEARING - Rear - Tapered Roller - 2-1/4" SHAFT	2	M621S4158B	M621S4158B
	BEARING - Rear - Tapered Roller - 1-3/8" SHAFT (*)	2	<i>M621S4158F</i>	<i>M621S4158F</i>
47	GASKET - Rectangular Inlet Flange	1	M03HP334134	M03HP334136
51	SUPPORT - HDRI Pedestal Mount-see gear cases	1	M03HP177674	M03HP177674

(\*) These part number apply for gearcases with 1-3/8" input shaft on some older models.

Please provide serial number when ordering parts for these models

## MODELS R4HDRI, R6HDRI

### HEAVY DUTY COVER OPTIONS

ITEM	DESCRIPTION	QTY.	PART NO.	
			R4HDRI	R6HDRI
7	COVER - Heavy-Duty Rectangular Inlet - Incl. #5 and #6 above	1	M03AP185437	M03AP185437
7	COVER - HDRI Deaerator/Degasser - Incl. #5 and #6 above	1	M03AP250555	M03AP250555
7	COVER - HDRI Water Flush Seal - Incl. #5 and #6 above	1	M03AP257405	M03AP257405

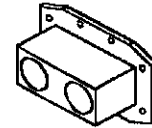

STD HEAVY DUTY COVER

### FRONT OUTLET COVER OPTIONS (use with body for HDRI Front Outlet)

7	COVER - HDRI Front Outlet - 3 in. Th'd Bevel Seat	1	M03AP255358	M03AP255358
7	COVER - HDRI Front Outlet - 3 in. Th'd PV Seat	1	M03AP454224	M03AP454224
7	COVER - HDRI Front Outlet - 3 in. PV Clamp	1	M03AP454225	M03AP454225
7	COVER - HDRI Front Outlet - 3 in. ISS (APV-SP)	1	M03AP447401	M03AP447401
7	COVER - HDRI Front Outlet - 3 in. Tri-Clamp	1	M03AP401473	M03AP401473
7	COVER - HDRI Front Outlet - 3 in. Cherry-Burrell "I"	1	M03AP454226	M03AP454226
7	COVER - HDRI Front Outlet - 3 in. Butt Weld	1	M03AP454227	M03AP454227
7	COVER - HDRI Front Outlet - 4 in. Th'd Bevel Seat	1	N/A	M03AP271885
7	COVER - HDRI Front Outlet - 4 in. Th'd PV Seat	1	N/A	M03AP454228
7	COVER - HDRI Front Outlet - 4 in. PV Clamp	1	N/A	M03AP288748
7	COVER - HDRI Front Outlet - 4 in. ISS (APV-SP)	1	N/A	M03AP454229
7	COVER - HDRI Front Outlet - 4 in. Tri-Clamp	1	N/A	M03AP411942
7	COVER - HDRI Front Outlet - 4 in. Cherry-Burrell "I"	1	N/A	M03AP454230
7	COVER - HDRI Front Outlet - 4 in. Butt Weld	1	N/A	M03AP381392

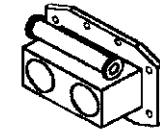

HEAVY DUTY COVER WITH  
DEAERATOR/DEGASSER

### FRONT OUTLET COVER OPTIONS with DEAERATOR/DEGASSER (use with body for HDRI Front Outlet)

7	COVER - HDRI D/D Front Outlet - 3 in. Th'd Bevel Seat	1	M03AP830461	M03AP830461
7	COVER - HDRI D/D Front Outlet - 3 in. Th'd PV Seat	1	M03AP830460	M03AP830460
7	COVER - HDRI D/D Front Outlet - 3 in. PV Clamp	1	M03AP830459	M03AP830459
7	COVER - HDRI D/D Front Outlet - 3 in. ISS (APV-SP)	1	M03AP830458	M03AP830458
7	COVER - HDRI D/D Front Outlet - 3 in. Tri-Clamp	1	M03AP830457	M03AP830457
7	COVER - HDRI D/D Front Outlet - 3 in. Cherry-Burrell "I"	1	M03AP830456	M03AP830456
7	COVER - HDRI D/D Front Outlet - 3 in. Butt Weld	1	M03AP830455	M03AP830455
7	COVER - HDRI D/D Front Outlet - 4 in. Th'd Bevel Seat	1	N/A	M03AP830453
7	COVER - HDRI D/D Front Outlet - 4 in. Th'd PV Seat	1	N/A	M03AP830452
7	COVER - HDRI D/D Front Outlet - 4 in. PV Clamp	1	N/A	M03AP830451
7	COVER - HDRI D/D Front Outlet - 4 in. ISS (APV-SP)	1	N/A	M03AP830450
7	COVER - HDRI D/D Front Outlet - 4 in. Tri-Clamp	1	N/A	M03AP830449
7	COVER - HDRI D/D Front Outlet - 4 in. Cherry-Burrell "I"	1	N/A	M03AP830448
7	COVER - HDRI D/D Front Outlet - 4 in. Butt Weld	1	N/A	M03AP830447

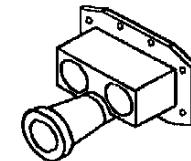

STD HEAVY DUTY COVER  
WITH FRONT OUTLET

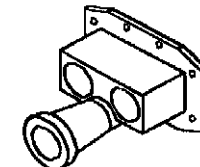

HEAVY DUTY COVER WITH  
DEAERATOR/DEGASSER  
AND FRONT OUTLET

## MODELS R4HDRI, R6HDRI

### BODY OPTIONS

ITEM	DESCRIPTION	QTY.	PART NO.	
			R4HDRI	R6HDRI
19	BODY - HDRI - Front Outlet (use with front outlet cover)	1	M03AP254597	M03AP255366
47	GASKET - Rectangular Inlet Flange	1	M03HP334134	M03HP334136

19	BODY - HDRI - 3" Bevel Seat	1	M03AP242000	M03AP271844
19	BODY - HDRI - 3" Threaded PV Seat	1	M03AP242008	M03AP271839
19	BODY - HDRI - 3" APC-PV Clamp	1	M03AP242008	M03AP271841
19	BODY - HDRI - 3" ISS (APV - SP)	1	M03AP242001	M03AP271832
19	BODY - HDRI - 3" Tri-Clamp	1	M03AP242008	M03AP271842
19	BODY - HDRI - 3" Cherry-Burrell "I"	1	M03AP242004	M03AP271835
19	BODY - HDRI - 3" Flange	1	M03AP242013	M03AP271845
19	BODY - HDRI - 3" Butt Weld	1	M03AP452723	M03AP271843
47	GASKET - Rectangular Inlet Flange	1	M03HP334134	M03HP334136

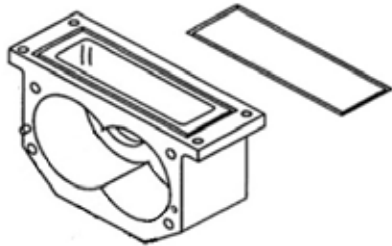

BODY-HDRI Use with  
FRONT OUTLET COVER

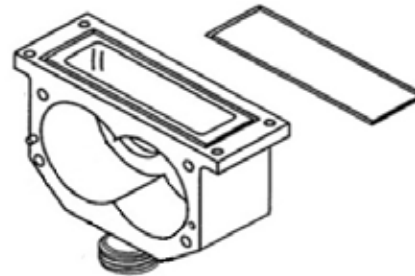

BODY-HDRI STD OUTLET

## MODELS R4HDRI, R6HDRI

### GEARCASE OPTIONS

ITEM	DESCRIPTION	QTY.	PART NO.	
			R4HDRI	R6HDRI
28	GEARCASE & COVER ASSY - "B" MOUNT (STANDARD)	1	M03AP262754	M03AP262754
28	GEAR CASE & COVER ASSY -TF-Ped/floor mount	1	M03AP280214	M03AP280214

### GEAR CASE & PLUG ASSEMBLY - (Includes Items 28,29,32,33,35,38,39,40)

28B	GEAR CASE & PLUG ASSY - "B" MOUNT (STANDARD)	1	M03WP262754	M03WP262754
28B	GEAR CASE & PLUG ASSY - TF-PED/FLR MT	1	M03WP280214	M03WP280214
28B	GEAR CASE & PLUG ASSY - TF-CEILING MT	1	M03WP280214	M03WP280214

### GEAR CASE ASSEMBLY - INCL SHAFTS - (Includes Items 25-29,32-40, 42-46)

28A	GEAR CASE ASY - TOP SHAFT	1	M03AP454789	M03AP454518
28A	GEAR CASE ASY - BOTTOM SHAFT	1	M03AP454790	M03AP454519
28A	GEAR CASE ASY -TOP FEED - RH SHAFT-PED MT (+)	1	M03AP454793	M03AP454522
28A	GEAR CASE ASY - TOP FEED - LH SHAFT-PED MT (+)	1	M03AP454794	M03AP454523
28A	GEAR CASE ASY -TOP FEED - RH SHAFT-FLR MT	1	M03AP454797	M03AP454526
28A	GEAR CASE ASY - TOP FEED - LH SHAFT-FLR MT	1	M03AP454798	M03AP454527

(+) These items include pedestal (#50) and support bracket (#51)

### GEARCASE ASSEMBLY OPTIONS - WATER FLUSH SEAL (Includes Items 25-29,32-40, 42-46)

28A	GEAR CASE ASY - TOP SHAFT	1	M03AP454791	M03AP454520
28A	GEAR CASE ASY - BOTTOM SHAFT	1	M03AP454792	M03AP454521
28A	GEAR CASE ASY -TOP FEED - RH SHAFT-PED MT (+)	1	M03AP454795	M03AP454524
28A	GEAR CASE ASY - TOP FEED - LH SHAFT-PED MT (+)	1	M03AP454796	M03AP454525

(+) These items include pedestal (#50) and support bracket (#51)

41	SUPPORT POST - PEDESTAL MOUNT	1	M03HP162866	M03HP162866
51	SUPPORT BRACKET - PEDESTAL MOUNT	1	M03HP177674	M03HP177674

\*\*\*\*\* NOTE: All gearcases listed on this page have 2-1/4" drive shaft. \*\*\*\*\*

\*\*\*\*\* Some older models have 1-3/8" drive shaft. Call for part number (serial number required.). \*\*\*\*\*

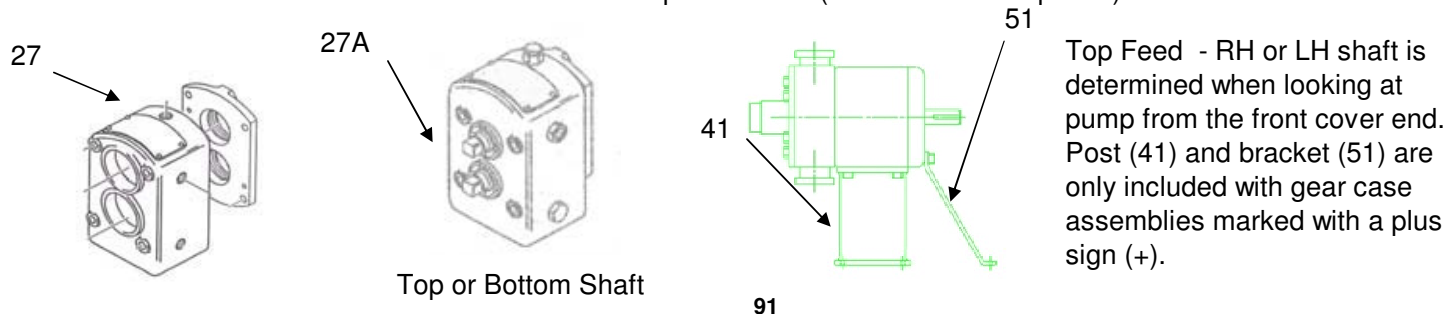

# MODEL R700HD

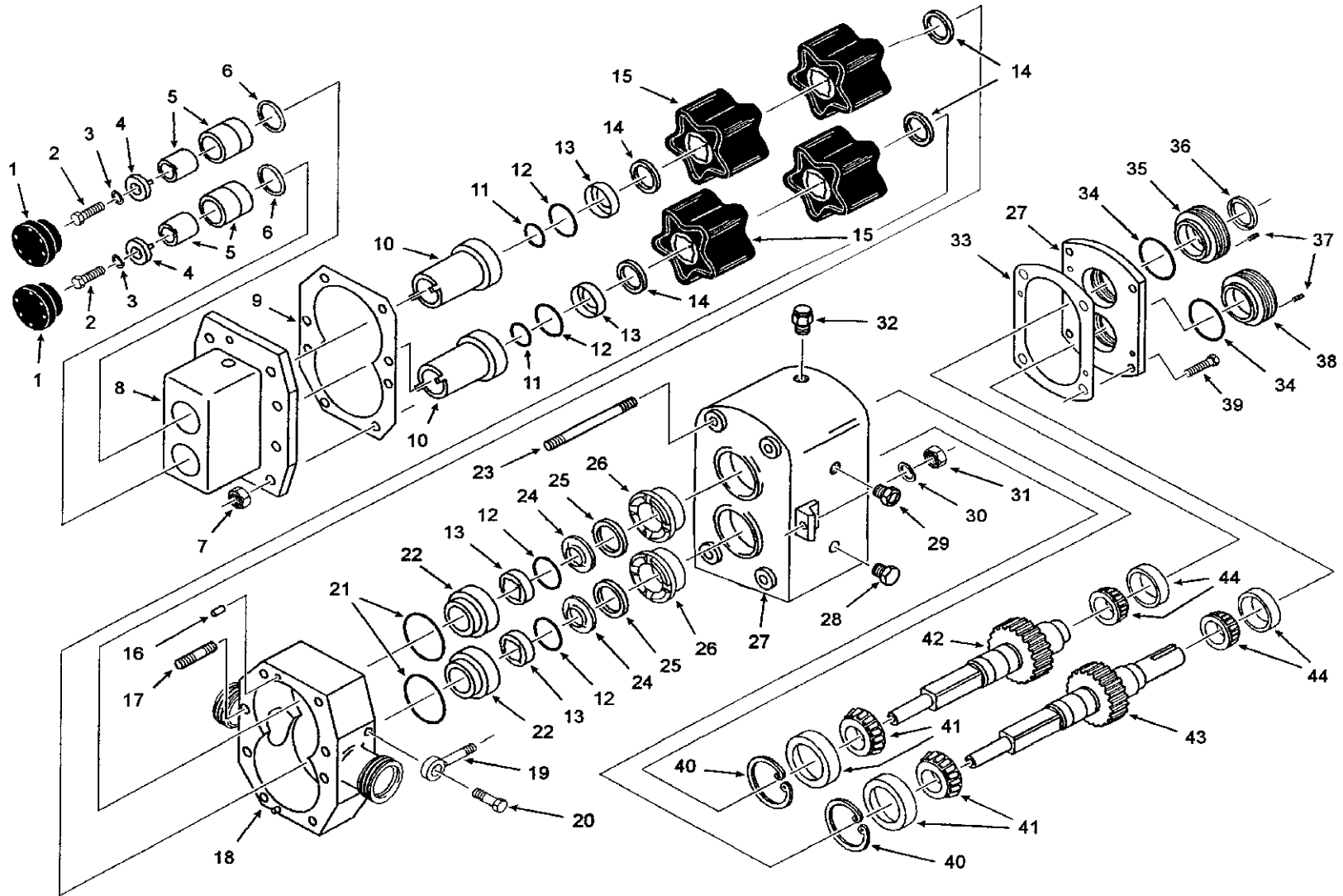

## MODEL R700HD

ITEM	DESCRIPTION	QTY.	R700HD
1	CAP - Bearing End, Heavy-Duty	2	M03HP225266
2	SCREW	2	M521P229095
3	WASHER	2	M523V008819
4	PLATE & PIN (RETAINING WASHER)	2	M03AP225267
5	BEARING ASSEMBLY - Outboard Complete (INCL 5A & 5B below)	2	M03AP232733
5A	Bearing - inner race	-	M03HP225661
5B	Bearing - outer race	-	M621S8184B
6	RING - Retainer	2	M03HP225033
7	NUT - Hex (Stainless Steel)	8	M523V006529
8	COVER - HEAVY DUTY - STANDARD (includes # 5 and #6 above)	1	M03AP185437
	COVER - HD Water Flush Seal (includes #5 and #6 above)	1	M03AP257405
	COVER - HD - Deaerator/degasser (includes #5 and #6 above)	1	M03AP250555
9	GASKET - Cover (Paper) Heavy-Duty (sold in boxes of 100)	1	M541P171854
10	CARTRIDGE - Front Seal & Spacer HD Seal	2	M03HP280219
	CARTRIDGE - Front Seal & Spacer WFS	2	M03HP257717
	CARTRIDGE - Front Seal & Spacer DEAERATOR/DEGASSER	2	M03HP232854
11	O-RING (Sold in pks of 10pcs)	2	M543S131402
12	O-RING - Pump Seal (Sold in pks of 10pcs)	4	M543S131405
13	BEARING - Seal (Stainless Steel)	2	M03HP137734
14	SEAL - Shaft (Sold in pks of 10pcs)	4	See Shaft Seals
15	ROTORS - 5 Lobe	4	See Rotors
16	PIN - Locating	2	M525S1670G
17	STUD - Short Round	4	M03HP167185
18	BODY - Heavy Duty Pump	1	see body section
19	EYE BOLT	2	M03AP233335
20	SCREW	2	M521V006695
21	O-RING - Rear Cartridge (sold in pks of 5pcs)	2	M543S131351
	O-RING - WFS (Sold in pks of 5pcs)	2	M543S131349
22	CARTRIDGE - Rear Seal & Spacer HD Seal Kit	2	M03HP171697
	CARTRIDGE - Rear Seal & Spacer WFS Kit	2	M03HP257381
	CARTRIDGE - Rear Seal & Spacer Deaerator/degasser	2	M03HP331708
23	STUD - Long Round (3 round studs and 1 hex stud per pump)	3	M03HP167060
	STUD - Long Hex (3 round studs and 1 hex stud per pump)	1	M03HP167061



## MODEL R700HD

~

ITEM	DESCRIPTION	QTY.	R700HD
24	RING - Seal (Sold in packs of 5pcs)	2	M03HP137738
25	SEAL - Front Oil	2	M543SK609
26	PLUG - Locating	2	M03HP167428
	PLUG - Locating, WFS	2	M03HP257380
27	GEAR CASE ASSEMBLY --see Gearcase section	1	see gearcases
28	OIL PLUG	2	M569P454190
29	SIGHT GLASS	1	M569P454191
30	WASHER	2	M523V007193
31	NUT	2	M523V006529
32	BREATHER/OIL FILLER	1	M569P454192
33	GASKET - Gear Case	1	M549P137756
34	O-RING - Bearing Seal 2-1/4" shaft (Sold in pks of 5pcs)	2	M543S131422
	O-RING - Bearing Seal 1-3/8" shaft (*) (Sold in pks of 10pcs)	2	M543S131413 (*)
35	NUT - Bearing Adjustment - 2-1/4 SHAFT	1	M03HP255805
	NUT - Bearing Adjustment - 1-3/8 SHAFT (*)	1	M03HP133580 (*)
36	SEAL - Real Oil 2-1/4" shaft	1	M543SK609
	SEAL - Real Oil 1-3/8" shaft (*)	1	M543SK608 (*)
37	SCREW - Set	4	M522V006970
38	NUT - Bearing Adjustment & Seal Retainer - 2-1/4 SHAFT	1	M03HP255804
	NUT - Bearing Adjustment & Seal Retainer - 1-3/8 SHAFT (*)	1	M03HP133578 (*)
39	SCREW	6	M522V006804
40	RING - Retaining	2	M689P138716
41	BEARING - Front - Tapered Roller	2	M621S4158B
42	SHAFT & GEAR ASSEMBLY - Short -2-1/4 SHAFT	1	M03AP257564
	SHAFT & GEAR ASSEMBLY - Short - 1-3/8 SHAFT (*)	1	M03AP232813 (*)
43	SHAFT & GEAR ASSEMBLY - Long - 2-1/4 SHAFT	1	M03AP257565
	SHAFT & GEAR ASSEMBLY - Long - 1-3/8 SHAFT (*)	1	M03AP232814 (*)
44	BEARING - Rear - Tapered Roller - 2-1/4" SHAFT	2	M621S4158B
	BEARING - Rear - Tapered Roller - 1-3/8" SHAFT (*)	2	M621S4158F (*)

(\*) These part number apply for gearcases with 1-3/8" input shaft on some older models.

Please provide serial number when ordering parts for these models

## MODEL R700HD

### COVER OPTIONS

ITEM	DESCRIPTION	QTY.	R700HD
8	COVER - HEAVY DUTY - STANDARD	1	M03AP185437
8	COVER - HD - STD - WATER FLUSH SEAL	1	M03AP257405
8	COVER - HD - Deaerator/degasser	1	M03AP250555

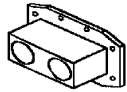

STD HEAVY DUTY COVER

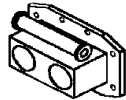

HEAVY DUTY COVER WITH  
DEAERATOR/DEGASSER

### BODY OPTIONS

18	BODY HD - 4" Butt Weld	1	M03AP267958
18	BODY HD - 4" Bevel Seat	1	M03AP267951
18	BODY HD - 4" Th'd PV Seat	1	M03AP267952
18	BODY HD - 4" APC-PV Clamp	1	M03AP267950
18	BODY HD - 4" ISS (APV-SP) Clamp	1	M03AP267960
18	BODY HD - 4" Tri-Clamp	1	M03AP267953
18	BODY HD - 4" Cherry Burrell "I"	1	M03AP267959
18	BODY HD - 4 " - Flange	1	M03AP489771
18	BODY HD - 4" Butt Weld	TOP FEED OR WFS	M03AP267966
18	BODY HD - 4" Bevel Seat	TOP FEED OR WFS	M03AP267961
18	BODY HD - 4" Th'd PV Seat	TOP FEED OR WFS	M03AP267962
18	BODY HD - 4" APC-PV Clamp	TOP FEED OR WFS	M03AP267963
18	BODY HD - 4" ISS (APV-SP) Clamp	TOP FEED OR WFS	M03AP267964
18	BODY HD - 4" Tri-Clamp	TOP FEED OR WFS	M03AP267965
18	BODY HD - 4" Cherry Burrell "I"	TOP FEED OR WFS	M03AP267967
18	BODY HD - 4 " - Flange	TOP FEED OR WFS	N/A

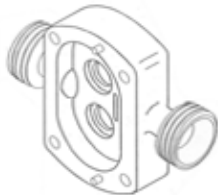

# MODEL R700HD

## GEARCASE OPTIONS

ITEM	DESCRIPTION	QTY.	R700HD	
			2-1/4" dia	1-3/8" dia (*)
27	GEAR CASE & COVER ASSEMBLY	1	M03AP262776	M03AP262776
27	GEAR CASE & COVER ASSY -TF-Ped/floor mount	1	M03AP257829	M03AP257829
27	GEAR CASE & COVER ASSEMBLY - TF-CEILING MOUNT	1	M03AP257828	M03AP257828

### GEAR CASE & PLUG ASSEMBLY - (Includes Items 27-29, 32, 33, 35, 38, 39)

			2-1/4" shaft	1-3/8" shaft (*)
27B	GEAR CASE & PLUG ASSEMBLY (	1	M03WP262776	-
27B	GEAR CASE & PLUG ASSY - TF-PED/FLR MT	1	M03WP257829	M03WP257344 (*)
27B	GEAR CASE & PLUG ASSY-TF-CEILING MT	1	M03WP257828	M03WP257344 (*)

### GEAR CASE ASSEMBLY - INCL SHAFTS - (Includes Items 24-29, 32-44)

			2-1/4" shaft	1-3/8" shaft (*)
27A	GEAR CASE ASY - TOP SHAFT	1	M03AP458329	M03AP458327 (*)
27A	GEAR CASE ASY - BOTTOM SHAFT	1	M03AP458330	M03AP458328 (*)
27A	GEAR CASE ASY -TOP FEED - RH SHAFT-PED MT (+)	1	M03AP458337	M03AP458335 (*)
27A	GEAR CASE ASY - TOP FEED - LH SHAFT-PED MT (+)	1	M03AP458338	M03AP458336 (*)
27A	GEAR CASE ASY -TOP FEED - RH SHAFT-FLR MT	1	M03AP458345	M03AP458343 (*)
27A	GEAR CASE ASY - TOP FEED - LH SHAFT-FLR MT	1	M03AP458346	M03AP458344 (*)
27A	GEAR CASE ASY -TOP FEED - RH SHAFT-CEILING MT	1	M03AP458347	(*)
27A	GEAR CASE ASY - TOP FEED - LH SHAFT-CEILING MT	1	M03AP458348	(*)

(+) These items include support post (#50) and support bracket (#51)

### GEARCASE ASSEMBLY OPTIONS - WATER FLUSH SEAL

(Includes Items 24-29, 32-44)

			2-1/4" shaft	1-3/8" shaft (*)
27A	GEAR CASE ASY - TOP SHAFT	1	M03AP458333	M03AP458331 (*)
27A	GEAR CASE ASY - BOTTOM SHAFT	1	M03AP458334	M03AP458332 (*)
27A	GEAR CASE ASY -TOP FEED - RH SHAFT-PED MT (+)	1	M03AP458341	M03AP458339 (*)
27A	GEAR CASE ASY - TOP FEED - LH SHAFT-PED MT (+)	1	M03AP358342	M03AP458340 (*)

27A (+) These items include support post (#50) and support bracket (#51)

50	SUPPORT POST - PEDESTAL MOUNT	1	M03AP389146	M03AP389146
51	SUPPORT BRACKET - PEDESTAL MOUNT	1	M03HP233364	M03HP233364

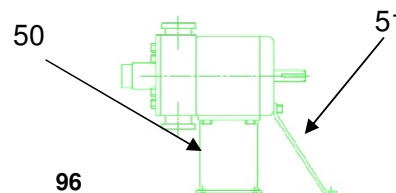
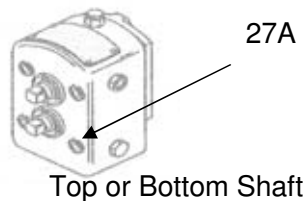
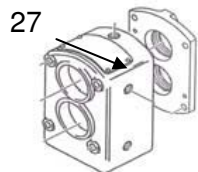

Top Feed - RH or LH shaft is determined when looking at pump from the front cover end. Post (50) and bracket (51) are only included with gear case assemblies marked with an asterisk (\*).

# MODEL R700HDRI

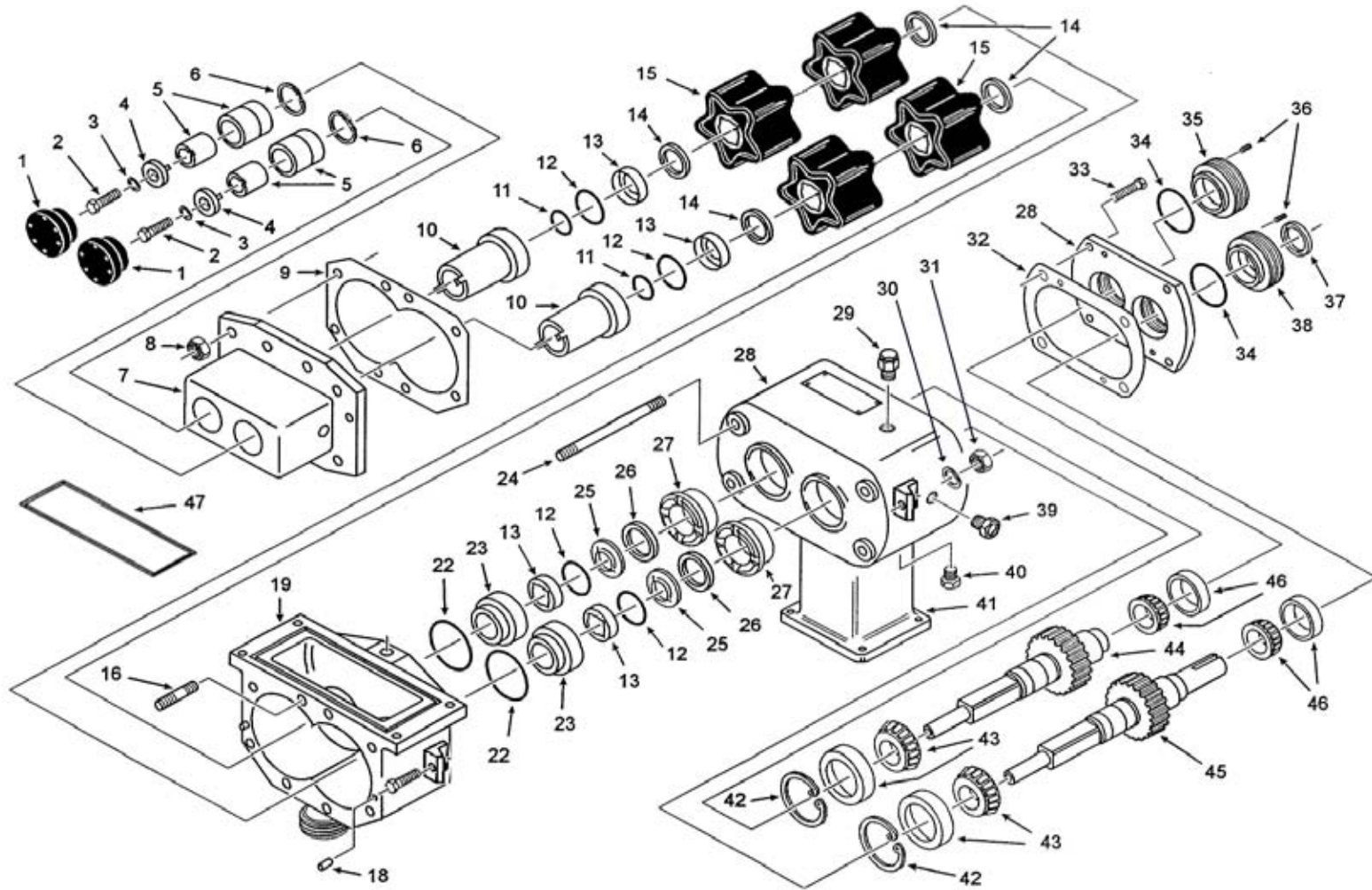

## MODEL R700HDRI

ITEM	DESCRIPTION	QTY.	PART NO.
			R700HDRI
1	CAP - Bearing End, Heavy Duty	2	M03HP225266
2	BOLT	2	M521P229095
3	WASHER	2	M523V008819
4	PLATE & PIN - Bearing - Retainer, HD	2	M03AP225267
5	BEARING Assembly - Outboard Complete	2	M03AP232733
5A	Bearing - inner race	-	M03HP225661
5B	Bearing - outer race	-	M621S8184B
6	RING - Retainer	2	M03HP225033
7	COVER - see cover section for available options	1	See Covers
8	NUT - Hex (Stainless Steel)	8	M523V006529
9	GASKET - Cover (Paper) Heavy-Duty (sold in pks of 100)	1	M541P171854
10	CARTRIDGE - Front Seal & Spacer HD Seal (standard)	2	M03HP280219
	CARTRIDGE - Front Seal & Spacer WFS	2	M03HP257717
	CARTRIDGE - Front Seal & Spacer DEARATOR/DEGASSER	2	M03HP232854
11	O-RING - Bearing Seal, Heavy-Duty (Sold in pks of 10pcs)	2	M543S131402
12	O-RING - Pump Seal (Sold in pks of 10pcs)	4	M543S131405
13	BEARING - Seal, SS, Standard	4	M03HP137734
14	SEAL - Shaft (Sold in pks of 10pcs)	2	See Shaft Seals
15	ROTORS - 5 Lobe	4	See Rotors
16	STUD - Short Round	4	M03HP167185
17	SCREW	2	M521V006695
18	PIN - Locating	2	M525S1670G
19	BODY - see body section	1	See Body Section
20	EYE BOLT ("B" MOUNT ONLY)	2	M03AP233335
21	SCREW ("B" MOUNT ONLY)	2	M521V006695
22	O-RING - Rear Cartridge (Sold in pks of 5pcs)	2	M543S131351
23	CARTRIDGE - Rear Seal & Spacer HD Seal Kit	2	M03HP171697
23	CARTRIDGE - Rear Seal & Spacer Deaerator/Degasser Seal Kit	2	M03HP331708
24	STUD - Long Round	4	M03HP167060
25	RING - Seal (Sold in pks of 5pcs)	2	M03HP137738
26	SEAL - Front Oil	2	M543SK609
27	PLUG - Locating	2	M03HP167428
	PLUG - Locating, WFS	2	M03HP257380
28	GEAR CASE ASSEMBLY --see Gearcase section	1	See Gearcases
29	BREATHER/OIL FILLER	1	M569P454192

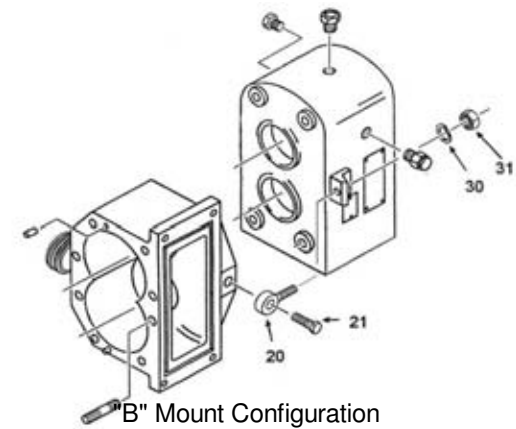

## MODEL R700HDRI

ITEM	DESCRIPTION	QTY.	PART NO.	
				R700HDRI
30	WASHER	1	M523V007193	
31	NUT	1	M523V006529	
32	GASKET - Gear Case	1	M549P137756	
33	SCREW	6	M522V006804	
34	O-RING - Bearing Seal 2-1/4" shaft (Sold in pks of 5pcs)	2	M543S131422	
	O-RING - Bearing Seal 1-3/8" shaft (*) (Sold in pks of 10)	2		<i>M543S131413</i> (*)
35	NUT - Bearing Adjustment - 2-1/4 SHAFT	1	M03HP255805	
	NUT - Bearing Adjustment - 1-3/8 SHAFT (*)	1		<i>M03HP133580</i> (*)
36	SCREW	4	M522V006970	
37	SEAL - Real Oil 2-1/4" shaft	1	M543SK609	
	SEAL - Real Oil 1-3/8" shaft	1		<i>M543SK608</i> (*)
38	NUT - Bearing Adjustment & Seal Retainer - 2-1/4 SHAFT	1	M03HP255804	
	NUT - Bearing Adjustment & Seal Retainer - 1-3/8 SHAFT (*)	1		<i>M03HP133578</i> (*)
39	SIGHT GLASS	1	M569P454191	
40	OIL PLUG	1	M569P454190	
41	PEDESTAL	1	M03HP389146	
42	RING - Retaining	1	M689P138716	
43	BEARING - Gear Case - Front (Tapered Roller)	2	M621S4158B	
44	SHAFT & GEAR ASSEMBLY - Short -2-1/4 SHAFT	1	M03AP257564	
44	SHAFT & GEAR ASSEMBLY - Short - 1-3/8 SHAFT (*)	1		<i>M03AP232813</i> (*)
45	SHAFT & GEAR ASSEMBLY - Long - 2-1/4 SHAFT	1	M03AP257565	
45	SHAFT & GEAR ASSEMBLY - Long - 1-3/8 SHAFT (*)	1		<i>M03AP232814</i> (*)
46	BEARING - Rear - Tapered Roller	2	M621S4158B	
	BEARING - Rear - Tapered Roller	2		<i>M621S4158F</i> (*)
47	GASKET - Rectangular Inlet Flange	1	M03HP334137	
51	SUPPORT - HDRI Pedestal Mount-see gear cases	1	M03HP233364	

(\*) These part number apply for gearcases with 1-3/8" input shaft on some older models.

Please provide serial number when ordering parts for these models

## MODEL R700HDRI

### HEAVY DUTY COVER OPTIONS

ITEM	DESCRIPTION	QTY.	PART NO.
			R700HDRI
7	COVER - Heavy-Duty Rectangular Inlet	1	M03AP185437
7	COVER - HDRI Deaerator/Degasser	1	M03AP250555
7	COVER - HDRI Water Flush Seal	1	M03AP257405

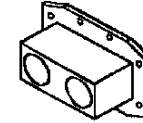

STD HEAVY DUTY COVER

### FRONT OUTLET COVER OPTIONS (use with body for HDRI Front Outlet)

7	COVER - HDRI Front Outlet - 3 in. Th'd Bevel Seat	1	M03AP255358
7	COVER - HDRI Front Outlet - 3 in. Th'd PV Seat	1	M03AP454224
7	COVER - HDRI Front Outlet - 3 in. PV Clamp	1	M03AP454225
7	COVER - HDRI Front Outlet - 3 in. ISS (APV-SP)	1	M03AP447401
7	COVER - HDRI Front Outlet - 3 in. Tri-Clamp	1	M03AP401473
7	COVER - HDRI Front Outlet - 3 in. Cherry-Burrell "I"	1	M03AP454226
7	COVER - HDRI Front Outlet - 3 in. Butt Weld	1	M03AP454227
7	COVER - HDRI Front Outlet - 4 in. Th'd Bevel Seat	1	M03AP271885
7	COVER - HDRI Front Outlet - 4 in. Th'd PV Seat	1	M03AP454228
7	COVER - HDRI Front Outlet - 4 in. PV Clamp	1	M03AP288748
7	COVER - HDRI Front Outlet - 4 in. ISS (APV-SP)	1	M03AP454229
7	COVER - HDRI Front Outlet - 4 in. Tri-Clamp	1	M03AP411942
7	COVER - HDRI Front Outlet - 4 in. Cherry-Burrell "I"	1	M03AP454230
7	COVER - HDRI Front Outlet - 4 in. Butt Weld	1	M03AP381392

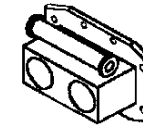

HEAVY DUTY COVER WITH  
DEAERATOR/DEGASSER

### FRONT OUTLET COVER OPTIONS with DEAERATOR/DEGASSER (use with body for HDRI Front Outlet)

7	COVER - HDRI D/D Front Outlet - 3 in. Th'd Bevel Seat	1	M03AP830461
7	COVER - HDRI D/D Front Outlet - 3 in. Th'd PV Seat	1	M03AP830460
7	COVER - HDRI D/D Front Outlet - 3 in. PV Clamp	1	M03AP830459
7	COVER - HDRI D/D Front Outlet - 3 in. ISS (APV-SP)	1	M03AP830458
7	COVER - HDRI D/D Front Outlet - 3 in. Tri-Clamp	1	M03AP830457
7	COVER - HDRI D/D Front Outlet - 3 in. Cherry-Burrell "I"	1	M03AP830457
7	COVER - HDRI D/D Front Outlet - 3 in. Butt Weld	1	M03AP830455
7	COVER - HDRI D/D Front Outlet - 4 in. Th'd Bevel Seat	1	M03AP830453
7	COVER - HDRI D/D Front Outlet - 4 in. Th'd PV Seat	1	M03AP830452
7	COVER - HDRI D/D Front Outlet - 4 in. PV Clamp	1	M03AP830451
7	COVER - HDRI D/D Front Outlet - 4 in. ISS (APV-SP)	1	M03AP830450
7	COVER - HDRI D/D Front Outlet - 4 in. Tri-Clamp	1	M03AP830449
7	COVER - HDRI D/D Front Outlet - 4 in. Cherry-Burrell "I"	1	M03AP830448
7	COVER - HDRI D/D Front Outlet - 4 in. Butt Weld	1	M03AP830447

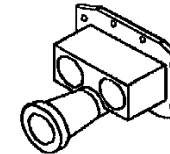

STD HEAVY DUTY COVER  
WITH FRONT OUTLET

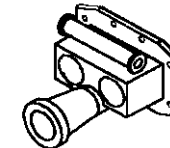

HEAVY DUTY COVER WITH  
DEAERATOR/DEGASSER  
AND FRONT OUTLET

## MODEL R700HDRI

### BODY OPTIONS

ITEM	DESCRIPTION	QTY.	PART NO.
			R700HDRI
19	BODY - HDRI - Front Outlet (use with front outlet cover)	1	M03AP454869
47	GASKET - Rectangular Inlet Flange	1	M03HP334137

19	BODY - HDRI - 4" Bevel Seat	1	M03AP389130
19	BODY - HDRI - 4" Threaded PV Seat	1	M03AP389131
19	BODY - HDRI - 4" APC-PV Clamp	1	M03AP389132
19	BODY - HDRI - 4" ISS (APV - SP)	1	M03AP389134
19	BODY - HDRI - 4" Tri-Clamp	1	M03AP389133
19	BODY - HDRI - 4" Cherry-Burrell "I"	1	M03AP389136
19	BODY - HDRI - 4" Flange	1	N/A
19	BODY - HDRI - 4" Butt Weld	1	M03AP389135
47	GASKET - Rectangular Inlet Flange	1	M03HP334137

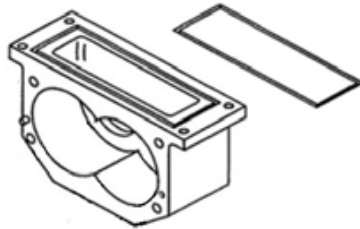

BODY-HDRI Use with  
FRONT OUTLET COVER

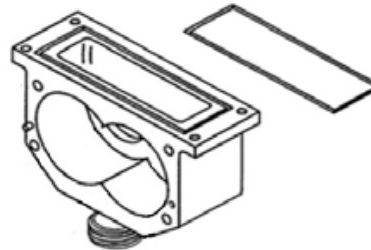

BODY-HDRI STD OUTLET



## MODEL R700HDRI

### GEARCASE OPTIONS FOR R700HDRI

ITEM	DESCRIPTION	QTY.	PART NO.	
			2-1/4" shaft	1-3/8" shaft (*)
28	GEAR CASE & COVER ASSY--B MOUNT (STANDARD)	1	M03AP262776	M03AP177376
28	GEAR CASE & COVER ASSY -TF-Ped/floor mount	1	M03AP257829	M03AP257344
28	GEAR CASE & COVER ASSY - TF-CEILING MT	1	M03AP257828	N/A

### GEAR CASE & PLUG ASSEMBLY - (Includes Items 28,29,32,33,35,38,39,40)

			2-1/4" shaft	1-3/8" shaft (*)
28B	GEAR CASE & PLUG ASSY- B MOUNT (STANDARD)	1	M03WP262776	M03WP177376
28B	GEAR CASE & PLUG ASSY - TF-PED/FLR MT	1	M03WP257829	M03WP257344 (*)
28B	GEAR CASE & PLUG ASSY - TF-CEILING MT	1	M03WP257828	N/A (*)

### GEAR CASE ASSEMBLY - INCL SHAFTS - (Includes Items 25-29,32-40, 42-46)

			2-1/4" shaft	1-3/8" shaft (*)
28A	HD GEAR CASE ASY- TOP SHAFT ( SIDE INLET)	1	M03AP458329	M03AP458327 (*)
28A	HD GEAR CASEY ASSY BOTTOM SHAFT (SIDE INLET)	1	M03AP458330	M03AP458328 (*)
28A	HD GEAR CASE ASY -TOP FEED - RH SHAFT-PED MT (+)	1	M03AP458337	M03AP458335 (*)
28A	HD GEAR CASE ASY - TOP FEED - LH SHAFT-PED MT (+)	1	M03AP458338	M03AP458336 (*)
28A	HD GEAR CASE ASY -TOP FEED - RH SHAFT-FLR MT	1	M03AP458345	M03AP458343 (*)
28A	HD GEAR CASE ASY - TOP FEED - LH SHAFT-FLR MT	1	M03AP458346	M03AP458344 (*)

(+) These items include pedestal (#50) and support bracket (#51)

### GEARCASE ASSEMBLY OPTIONS - WATER FLUSH SEAL

(Includes Items 25-29,32-40, 42-46)

			2-1/4" shaft	1-3/8" shaft (*)
28A	HD GEAR CASE ASY- TOP SHAFT ( SIDE INLET)	1	M03AP458333	M03AP458331 (*)
28A	HD GEAR CASE ASY-BOTTOM SHAFT (SIDE INLET)	1	M03AP458334	M03AP458332 (*)
28A	HD GEAR CASE ASY -TOP FEED - RH SHAFT-PED MT (+)	1	M03AP458341	M03AP458339 (*)
28A	HD GEAR CASE ASY - TOP FEED - LH SHAFT-PED MT (+)	1	M03AP358342	M03AP458340 (*)

(+) These items include pedestal (#50) and support bracket (#51)

41	SUPPORT POST - PEDESTAL MOUNT	1	M03AP389146	M03AP389146
51	SUPPORT BRACKET - PEDESTAL MOUNT	1	M03HP233364	M03HP233364

(\*) These part number apply for gearcases with 1-3/8" input shaft on some older models.

Please provide serial number when ordering parts for these models

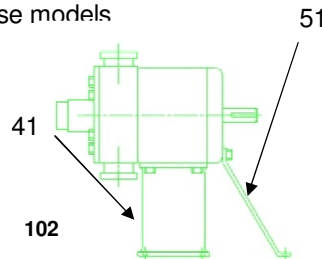
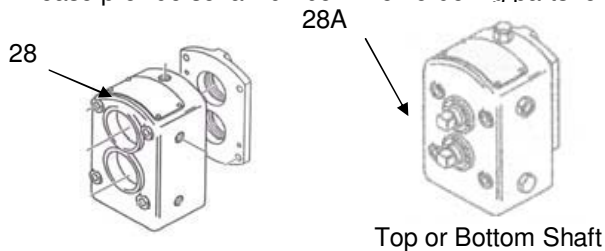

Top Feed - RH or LH shaft is determined when looking at pump from the front cover end. Post (41) and bracket (51) are only included with gear case assemblies marked with a plus sign (+).

## O-RING STYLE BODIES AND COVERS

ITEM	DESCRIPTION	PART NO.				
		QTY.	R1	R2	R3	R3HD
2	COVER	1	M03HP481337	M03HP481337	M03HP484049	M03HP484309
	COVER - Vented cover (optional) - see options	1	see VENTED COVER section			N/A
	COVER - Front - (Option: Deaerator/Degasser)	1	N/A	N/A	M03AP262079	N/A
3	GASKET - Cover O-Ring	1	M543S1313BS	M543S1313BS	M543S131437	M543S131437

### BODY OPTIONS

ITEM	DESCRIPTION	PART NO.				
		QTY.	R1	R2	R3	R3HD
8	BODY - 1.5" Butt Weld	1	M03AP484613	M03AP484100	M03HP484132	M03AP484202
8	BODY - 1.5" Bevel Seat	1	M03AP484608	M03AP484095	M03AP484127	M3AP484197
8	BODY - 1.5" Th'd PV Seat	1	M03AP484609	M03AP484096	M03AP484128	M3AP484198
8	BODY - 1.5" PV Clamp	1	M03HP484610	M03AP484097	M03AP484129	M03AP484199
8	BODY - 1.5" ISS	1	M03AP484611	M03AP484098	M03AP484130	M03AP484200
8	BODY - 1.5" Tri-Clamp	1	M03AP484612	M03AP484099	M03AP484131	M03AP484201
8	BODY - 1.5" Cherry Burrell "I"	1	M03AP484614	M03AP484101	M03AP484133	M03AP484202
8	BODY - 1.5" Flange	1	N/A	N/A	M03AP484134	M03AP484204
8	BODY- 2in. - Butt Weld	1	N/A	N/A	M03HP484140	M03AP484210
8	BODY - 2" Bevel Seat	1	N/A	N/A	M03AP484135	M03AP484205
8	BODY - 2" Th'd PV Seat	1	N/A	N/A	M03AP484136	M03AP484206
8	BODY - 2" PV Clamp	1	N/A	N/A	M03AP484137	M03AP484207
8	BODY - 2" ISS (APV-SP) Clamp	1	N/A	N/A	M03AP484138	M03AP484208
8	BODY - 2" Tri-Clamp	1	N/A	N/A	M03AP484139	M03AP484209
8	BODY - 2" Cherry Burrell "I"	1	N/A	N/A	M03AP484141	M03AP484211
8	BODY - 2in. - Flange	1	N/A	N/A	M03AP484142	M03AP484212

## O-RING STYLE BODIES AND COVERS

ITEM	DESCRIPTION	QTY.	PART NO.		
			R2RI	R3RI	R3HDRI
2	COVER - STANDARD FLAT COVER	1	M03HP481337	M03HP484049	M03AP484367
4	ORING - Cover	1	M543S1313BS	M543S131320	M543S131437

### FRONT COVER OPTIONS

ITEM	DESCRIPTION	QTY.	PART NO.		
			R2RI	R3RI	R3HDRI
2	COVER - Deaerator/Degasser 1.5" in.	1	N/A	N/A	N/A
2	COVER - Front Outlet - 2 in. Th'd Bevel Seat	1	N/A	M03AP484158	M03AP484224
2	COVER - Front Outlet - 2 in. Th'd PV Seat	1	N/A	M03AP484159	M03AP484225
2	COVER - Front Outlet - 2 in. PV Clamp	1	N/A	M03AP484160	M03AP484226
2	COVER - Front Outlet - 2 in. ISS (APV-SP)	1	N/A	M03AP484161	M03AP484227
2	COVER - Front Outlet - 2 in. Tri-Clamp	1	N/A	M03AP484162	M03AP484228
2	COVER - Front Outlet - 2 in. Cherry-Burrell "I"	1	N/A	M03AP484164	M03AP484300
2	COVER - Front Outlet - 2 in. Butt Weld	1	N/A	M03AP484163	M03AP484229
2	COVER - D/D Front Outlet - 2 in. Th'd Bevel Seat	1	N/A	M03AP484167	N/A
2	COVER - D/D Front Outlet - 2 in. Th'd PV Seat	1	N/A	M03AP484168	N/A
2	COVER - D/D Front Outlet - 2 in. PV Clamp	1	N/A	M03AP484169	N/A
2	COVER - D/D Front Outlet - 2 in. ISS (APV-SP)	1	N/A	M03AP484170	N/A
2	COVER - D/D Front Outlet - 2 in. Tri-Clamp	1	N/A	M03AP484171	N/A
2	COVER - D/D Front Outlet - 2 in. Cherry-Burrell "I"	1	N/A	M03AP484173	N/A
2	COVER - D/D Front Outlet - 2 in. Butt Weld	1	N/A	M03AP484172	N/A

## O-RING STYLE BODIES AND COVERS

### BODY OPTIONS

ITEM	DESCRIPTION	QTY.	PART NO.		
			R2RI	R3RI	R3HDRI
9	BODY - Rect Inlet - 1.5" Butt Weld	1	M03HP484113	N/A	N/A
9	BODY - Rect Inlet - 1.5" Bevel Seat	1	M03AP484108	N/A	N/A
9	BODY - Rect Inlet - 1.5" Th'd PV Seat	1	M03AP484109	N/A	N/A
9	BODY - Rect Inlet - 1.5" APC-PV Clamp Seat	1	M03AP484110	N/A	N/A
9	BODY - Rect Inlet - 1.5" ISS	1	M03AP484111	N/A	N/A
9	BODY - Rect Inlet - 1.5" Tri-Clamp	1	M03AP484112	N/A	N/A
9	BODY - Rect Inlet - 1.5" Cherry Burrell "I"	1	M03AP484114	N/A	N/A
9	BODY - Rect Inlet - 1.5" 150# Flange	1	N/A	N/A	N/A
9	BODY - Rect Inlet - 2" Butt Weld	1	N/A	M03HP484154	M03AP484673
9	BODY - Rect Inlet - 2" Bevel Seat	1	N/A	M03AP484149	M03AP484985
9	BODY - Rect Inlet - 2" Th'd PV Seat	1	N/A	M03AP484150	M03AP484986
9	BODY - Rect Inlet - 2" APC-PV Clamp Seat	1	N/A	M03AP484151	M03AP484987
9	BODY - Rect Inlet - 2" ISS	1	N/A	M03AP484152	M03AP484988
9	BODY - Rect Inlet - 2" Tri-Clamp	1	N/A	M03AP484153	M03AP484989
9	BODY - Rect Inlet - 2" Cherry Burrell "I"	1	N/A	M03AP484155	M03AP484990
9	BODY - Rect Inlet - 2" 150# Flange	1	N/A	N/A	M03AP484674
9	BODY - Rect Inlet - use with Front Outlet Cover	1	N/A	M03HP484684	M03HP484685

## O-RING STYLE BODIES AND COVERS

ITEM	DESCRIPTION	PART NO.		
		QTY.	R4	R6
1	NUT - Hex (Stainless Steel)	8	M523V006529	M523V006529
	NUT - Wing (optional)	8	M727P397882	M727P397882
2	COVER - Standard Front Cover	1	M03HP481162	M03HP481162
	COVER - Vented cover (optional) - see options	1	see vented cover section	
	COVER - Front - (Option: Deaerator/Degasser)	1	see optional cover section	
3	ORING - Cover	1	M543S1313EQ	M543S1313EQ

### BODY OPTIONS

ITEM	DESCRIPTION	PART NO.		
		QTY.	R4	R6
8	BODY- 2" Butt Weld	1	M03HP484396	N/A
	BODY - 2" Bevel Seat	1	M03AP484391	N/A
	BODY - 2" Th'd PV Seat	1	M03AP484392	N/A
	BODY - 2" PV (APC) Clamp	1	M03AP484393	N/A
	BODY - 2" ISS (APV-SP) Clamp	1	M03AP484394	N/A
	BODY - 2" Tri-Clamp	1	M03AP484395	N/A
	BODY - 2" Cherry Burrell "I"	1	M03AP484397	N/A
	BODY - 2" Flange	1	M03AP484398	N/A
8	BODY- 2.5" Butt Weld	1	N/A	N/A
	BODY - 2.5" Bevel Seat	1	N/A	N/A
	BODY - 2.5" Th'd PV Seat	1	N/A	N/A
	BODY - 2.5" PV (APC) Clamp	1	N/A	N/A
	BODY - 2.5" ISS (APV-SP) Clamp	1	N/A	N/A
	BODY - 2.5" Tri-Clamp	1	N/A	N/A
	BODY - 2.5" Cherry Burrell "I"	1	N/A	N/A
	BODY - 2.5" - Flange	1	N/A	N/A
8	BODY- 3" Butt Weld	1	M03AP484735	M03AP484460
	BODY - 3" Bevel Seat	1	M03AP484729	M03AP484455
	BODY - 3" Th'd PV Seat	1	M03AP484730	M03AP484456
	BODY - 3" PV (APC) Clamp	1	M03AP484731	M03AP484457
	BODY - 3" ISS (APV-SP) Clamp	1	M03AP484732	M03AP484458
	BODY - 3" Tri-Clamp	1	M03AP484733	M03AP484459
	BODY - 3" Cherry Burrell "I"	1	M03AP474734	M03AP484461
	BODY - 3" - Flange	1	M03AP484736	M03AP484460

## O-RING STYLE BODIES AND COVERS

ITEM	DESCRIPTION	QTY.	PART NO.	
			R4RI	R6RI
2	COVER - Rectangular Inlet - STD FLAT COVER	1	M03HP481162	M03HP481162
3	ORING - Cover	1	M543S1313EQ	M543S1313EQ

2B	COVER - Front Outlet - 3" Butt Weld	1	M03AP484431	M03AP484491
2B	COVER - Front Outlet - 3" Th'd Bevel Seat	1	M03AP484426	M03AP484486
2B	COVER - Front Outlet - 3" Th'd PV Seat	1	M03AP484427	M03AP484487
2B	COVER - Front Outlet - 3" PV (APC) Clamp	1	M03AP484428	M03AP484488
2B	COVER - Front Outlet - 3" ISS (APV - SP)	1	M03AP484429	M03AP484489
2B	COVER - Front Outlet - 3" Tri-Clamp	1	M03AP484430	M03AP484490
2B	COVER - Front Outlet - 3" Cherry-Burrell "I"	1	M03AP484432	M03AP484492
2C	COVER - Deaerator/Degasser Front Outlet - 3" Butt Weld	1	M03AP484440	M03AP484802
2C	COVER - Deaerator/Degasser Front Outlet - 3" Th'd Bevel Seat	1	M03AP484435	M03AP484795
2C	COVER - Deaerator/Degasser Front Outlet - 3" Th'd PV Seat	1	M03AP484436	M03AP484796
2C	COVER - Deaerator/Degasser Front Outlet - 3" PV (APC) Clamp	1	M03AP484437	M03AP484798
2C	COVER - Deaerator/Degasser Front Outlet - 3" ISS (APV-SP)	1	M03AP484438	M03AP484799
2C	COVER - Deaerator/Degasser Front Outlet - 3" Tri-Clamp	1	M03AP484439	M03AP484800
2C	COVER - Deaerator/Degasser Front Outlet - 3" Cherry-Burrell "I"	1	M03AP484441	M03AP484801
33	PLUG - DEAERATOR/DEGASSER COVER (see below)	2	M03HP151283	M03HP151283

## O-RING STYLE BODIES AND COVERS

BODY OPTIONS			PART NO.	PART NO.
			4RI	6RI
10	BODY RI - 3" Butt Weld	1	M03HP484418	M03HP484478
10	BODY RI - 3" Bevel Seat	1	M03AP484413	M03AP484473
10	BODY RI - 3" Th'd PV Seat	1	M03AP484414	M03AP484474
10	BODY RI - 3" PV Clamp	1	M03AP484415	M03AP484475
10	BODY RI - 3" ISS (APV-SP) Clamp	1	M03AP484416	M03AP484476
10	BODY RI - 3" Tri-Clamp	1	M03AP484417	M03AP484477
10	BODY RI - 3" Cherry Burrell "I"	1	M03AP484419	M03AP484479
10	BODY RI - 3" - 150# Flange	1	O/A	O/A
10A	BODY RI - used with Front Outlet Cover Options (no outlet)	1	M03HP484738	M03HP484758

BODY OPTIONS			PART NO		
ITEM	DESCRIPTION	QTY.	R4HD	R6HD	
8	BODY- 3" Butt Weld	1	M03AP484727	M03AP484520	
	BODY - 3" Bevel Seat	1	M03AP484721	M03AP484515	
	BODY - 3" Th'd PV Seat	1	M03AP484722	M03AP484516	
	BODY - 3" PV (APC) Clamp	1	M03AP484723	M03AP484517	
	BODY - 3" ISS (APV-SP) Clamp	1	M03AP484724	M03AP484518	
	BODY - 3" Tri-Clamp	1	M03AP484725	M03AP484519	
	BODY - 3" Cherry Burrell "I"	1	M03AP484726	M03AP484521	
	BODY - 3" Flange	1	M03AP484728	M03AP484522	
8	BODY - 4" Butt-Weld	1	N/A	M03AP484528	
	BODY - 4" Bevel Seat	1	N/A	M03AP484523	
	BODY - 4" Th'd PV Seat	1	N/A	M03AP484524	
	BODY - 4" PV (APC) Clamp	1	N/A	M03AP484525	
	BODY - 4" ISS (APV-SP) Clamp	1	N/A	M03AP484526	
	BODY - 4" Tri-Clamp	1	N/A	M03AP484527	
	BODY - 4" Cherry Burrell "I"	1	N/A	M03AP484529	
	BODY - 4" Flange	1	N/A	M03AP484530	

## O-RING STYLE BODIES AND COVERS

### COVER OPTIONS

ITEM	DESCRIPTION	QTY	R4HD	R6HD
2	COVER - Standard	1	M03HP484368	M03HP384368
2	COVER - Vented cover (optional) - see options	1		
13	Oring - Cover	1	M543S1313EQ	M543S1313EQ

### BODY OPTIONS

ITEM	DESCRIPTION	PART NUMBERS		
		QTY.	R4HDRI	R6HDRI
8	BODY- 3" Butt Weld	1	M03AP484418	M03AP484478
	BODY - 3" Bevel Seat	1	M03AP484413	M03AP484473
	BODY - 3" Th'd PV Seat	1	M03AP484414	M03AP484474
	BODY - 3" PV (APC) Clamp	1	M03AP484415	M03AP484475
	BODY - 3" ISS (APV-SP) Clamp	1	M03AP484416	M03AP484476
	BODY - 3" Tri-Clamp	1	M03AP484417	M03AP484477
	BODY - 3" Cherry Burrell "I"	1	M03AP484419	M03AP484479
	BODY - 3" Flange	1	O/R	O/R
	Body - Front Outlet		M03HP484738	M03HP484758
8	BODY- Top Feed 2" Butt Weld	1	M03AP484396	N/A
	BODY - Top Feed 2" Bevel Seat	1	M03AP484391	N/A
	BODY - Top Feed 2" Th'd PV Seat	1	M03AP484392	N/A
	BODY - Top Feed 2" PV (APC) Clamp	1	M03AP484393	N/A
	BODY - Top Feed 2" ISS (APV-SP) Clamp	1	M03AP484394	N/A
	BODY - Top Feed 2" Tri-Clamp	1	M03AP484395	N/A
	BODY - Top Feed 2" Cherry Burrell "I"	1	M03AP484397	N/A
	BODY - Top Feed 2" - Flange	1	M03AP484398	N/A
8	BODY- Top Feed 3" Butt Weld	1	M03AP484725	M03AP484460
	BODY - Top Feed 3" Bevel Seat	1	M03P484729	M03AP484455
	BODY - Top Feed 3" Th'd PV Seat	1	M03AP484730	M03AP484456
	BODY - Top Feed 3" PV (APC) Clamp	1	M03AP484731	M03AP484457
	BODY - Top Feed 3" ISS (APV-SP) Clamp	1	M03AP484732	M03AP484458
	BODY - Top Feed 3" Tri-Clamp	1	M03AP484733	M03AP484459
	BODY - Top Feed 3" Cherry Burrell "I"	1	M03AP484734	M03AP484461
	BODY - Top Feed 3 " - Flange	1	M03AP484725	M03AP484462



## O-RING STYLE BODIES AND COVERS

ITEM	COVER OPTIONS	QTY	PART NO.	PART NO.
	DESCRIPTION		4HDRI	6HDRI
2	COVER - HD Rectangular Inlet	1	M03AP484368	M03AP484368
	COVER - HDRI Front Outlet - Bevel Seat 3"	1	M03AP484343	M03AP484486
	COVER - HDRI Front Outlet Th'd PV 3"	1	M03AP484344	M03AP484487
	COVER - HDRI Front Outlet PV Clamp 3"	1	M03AP484345	M03AP484488
2	COVER - HDRI Front Outlet ISS 3"	1	M03AP484346	M03AP484489
	COVER - HDRI Front Outlet Tri-Clamp 3"	1	M03AP484347	M03AP484490
	COVER - HDRI Front Outlet Cherry Burrell "I" 3"	1	M03AP484349	M03AP484492
	COVER - HDRI Front Outlet Butt Weld 3"	1	M03AP484348	M04AP484491
2	COVER - HDRI D/D Front Outlet Bevel Seat 3"	1	M03AP484352	M03AP484795
	COVER - HDRI D/D Front Outlet Th'd PV 3"	1	M03AP484353	M03AP484796
	COVER - HDRI D/D Front Outlet PV Clamp 3"	1	M03AP484354	M03AP484798
	COVER - HDRI D/D Front Outlet ISS 3"	1	M03AP484355	M03AP484799
	COVER - HDRI D/D Front Outlet Tri-Clamp 3"	1	M03AP484356	M03AP484800
	COVER - HDRI D/D Front Outlet Cherry Burrell "I" 3"	1	M03AP484358	M03AP484801
	COVER - HDRI D/D Front Outlet Butt Weld 3"	1	M03AP484357	M03AP484802

## MODELS R1, R2, R2RI, R3, R3RI, R3HD, R3HDRI

### VENTED COVER OPTION

ITEM	DESCRIPTION	PART NUMBERS				
		QTY.	R1	R2, R2RI	R3, R3RI	R3HD, R3HDRI
1	COVER - Inner - Vented	1	M03HP155248	M03HP155248	M03HP155568	N/A
2	GASKET - Cover (Rubber) - Vented	1	M543P155249	M543P155249	M543P155335	N/A
3	COVER - Outer - Vented	1	M03AP155367	M03AP155367	M03AP155370	N/A
4	PLUNGER - Vented Cover	1	M03HP156724	M03HP156724	M03HP151283	N/A
5	SPRING - Vented Cover	1	M622P151284	M622P151284	M622P151284	N/A
6	NUT - Lock Vented Cover	1	M03HP151287	M03HP151287	M03HP151287	N/A
7	NUT - Adjusting Vented Cover	1	M03HP151286	M03HP151286	M03HP151286	N/A
(A)	STUD HEX - (Option: Vented Cover)	1	M03HP255155	M03HP155250	M03HP155244	N/A
(B)	STUD - Round, Vented Cover	3	M03HP255154	M03HP155269	M03HP155251	N/A

(A) Item # 12 for std models, item # 15 for RI models

(B) Item # 25 for std models, item # 11 for RI models.

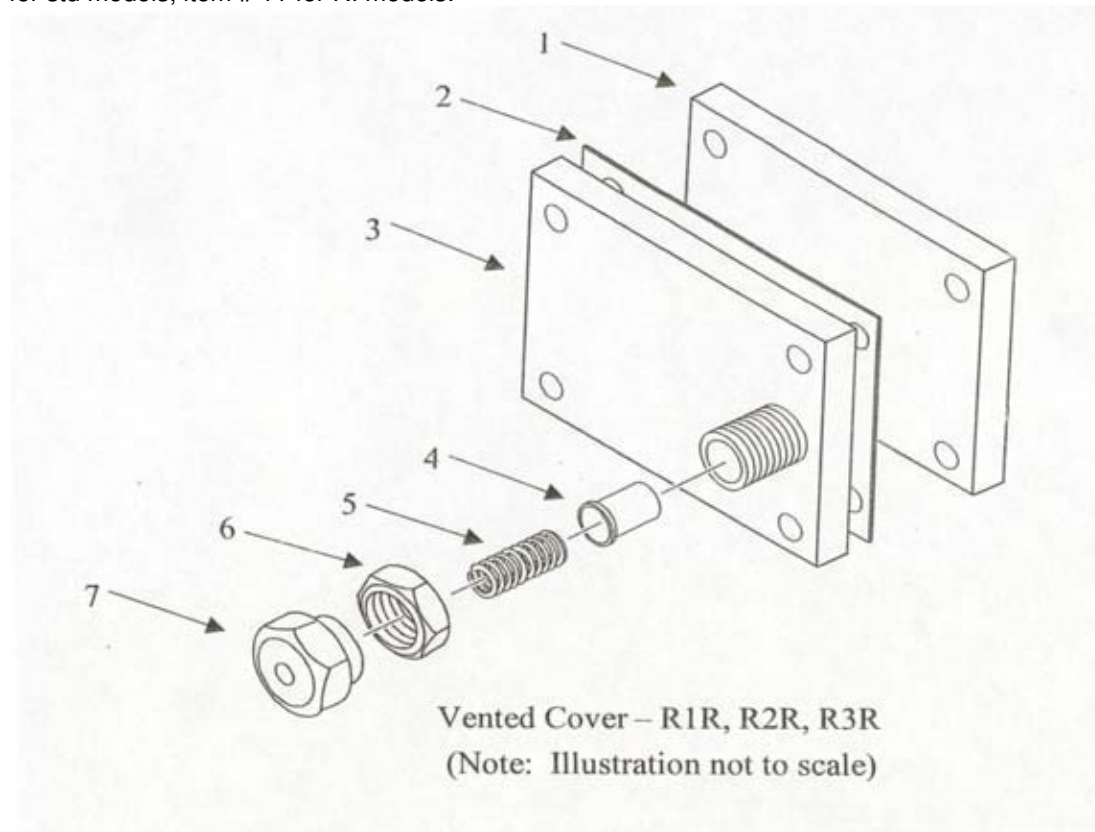

## MODELS R4, R4RI, R6 AND R6RI

### VENTED COVER OPTION R4, R4RI, R6, AND R6RI

1	COVER - Inner - Vented	1	M03HP151288
2	GASKET - Cover (Rubber) - Vented	1	M543P151282
3	COVER - Outer - Vented	1	M03AP155378
4	PLUNGER - Vented Cover	1	M03HP151283
5	SPRING - Vented Cover	1	M622P151284
6	NUT - Lock Vented Cover	1	M03HP151287
7	NUT - Adjusting Vented Cover	1	M03HP151286
9, 30 (*)	STUD - Round - short - vented cover	3	M03HP182255
9, 30 (*)	STUD - Hex - short - vented cover	1	M03HP192360

(\*) Item 30 for standard pumps, item 9 for RI pumps.

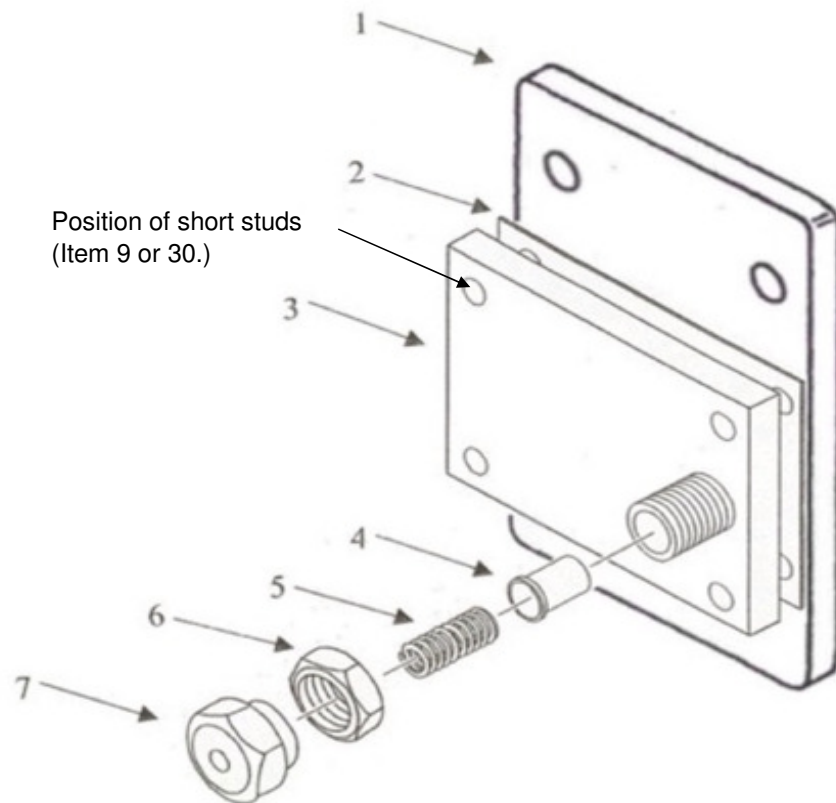

## MODELS R1, R2, R2RI, R3, R3RI, R3HD, R3HDRI

### WATER FLUSH SEAL KIT OPTION

ITEM	DESCRIPTION	PART NUMBERS				
		QTY.	R1	R2, R2RI	R3, R3RI	R3HD, R3HDRI
-	WATER FLUSH SEAL KIT - includes items 1-4	-	M03WP382303	M03WP382303	M03WP313086	M03WP313086
1	TEE - Brass - 3/16 in. x 1/8 in.	2	M568S6907A	M568S6907A	M568S6907A	M568S6907A
2	TUBING - Copper - 3/16 in. O.D.	-	M746S1855	M746S1855	M746S1855	M746S1855
3	O-RING (Sold in pks of 10pcs)	2	M543S1313BB	M543S1313BB	M543S131408	M543S131408
4	PLUG - Locating - water flush seal	2	M03HP304880	M03HP304880	M03HP255923	M03HP255923

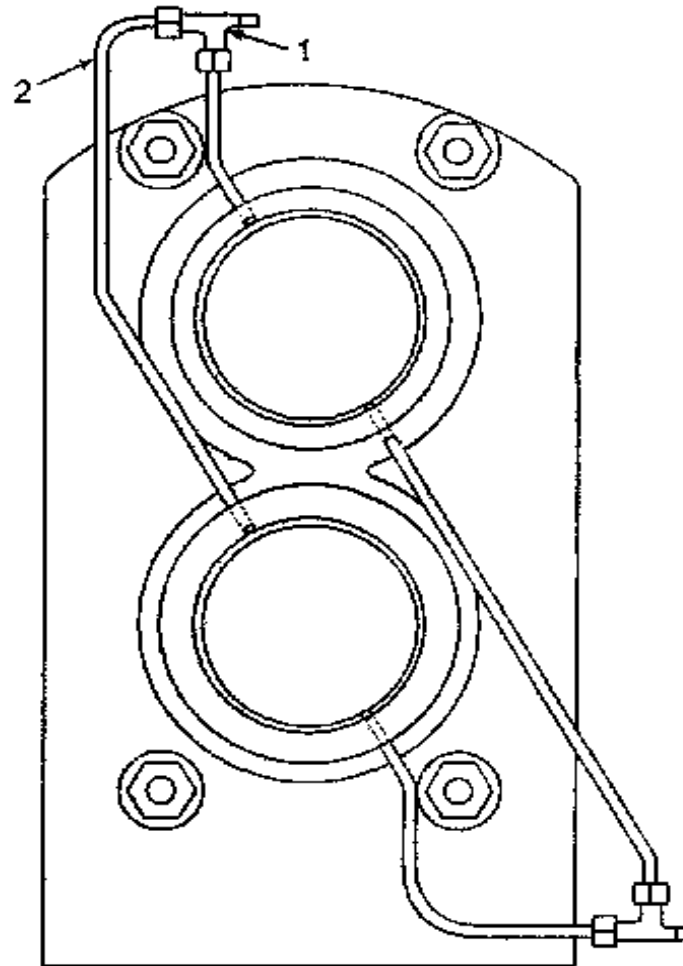
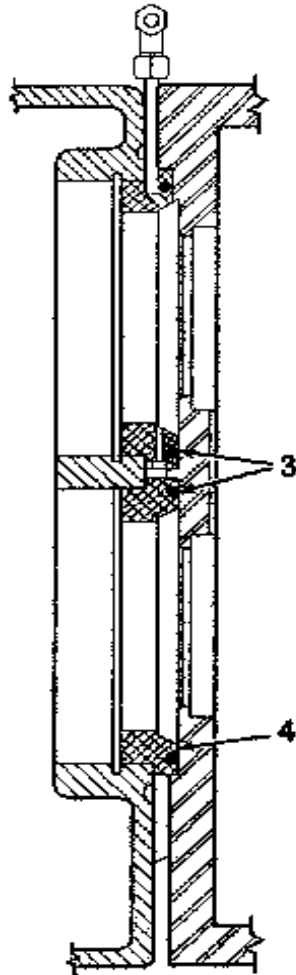

# MODELS R4, R4RI, R6 AND R6RI

## WATER FLUSH SEAL KIT OPTION MODELS R4, R4RI, R6, AND R6RI

-	WATER FLUSH SEAL KIT - includes items 1-4 listed below	-	M03WP218226
1	TEE - Brass - 3/16 in. x 1/8 in.	2	M568S6907A
2	TUBING - Copper - 3/16 in. O.D.	-	M746S1855
3	O-RING (Pkg. of 10)	2	M543S131422
4	PLUG - Locating - water flush seal	2	M03HP218225
-	INSTRUCTION - PIPING WATER FLUSH SEAL	-	M03XP218226

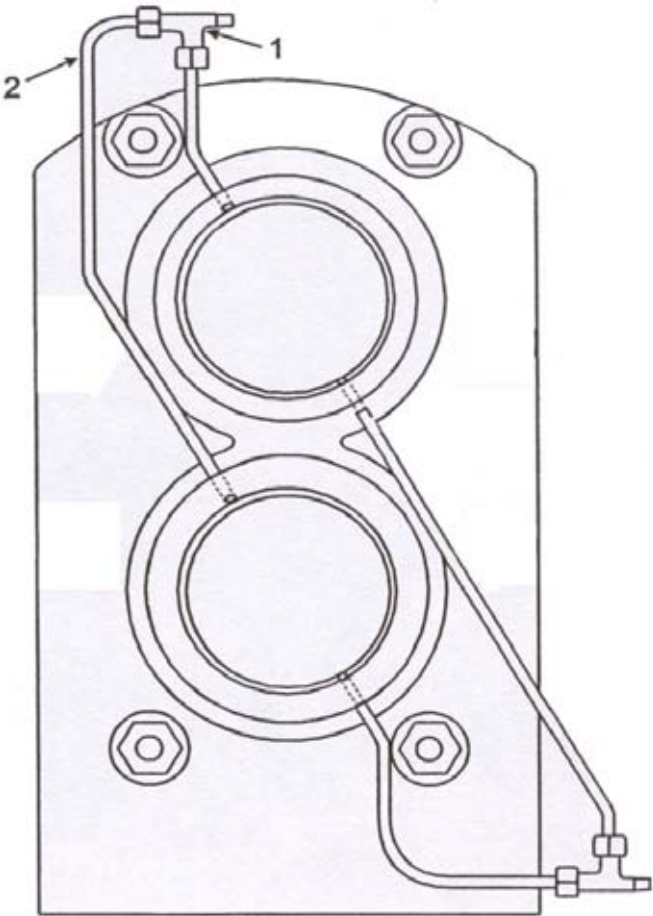
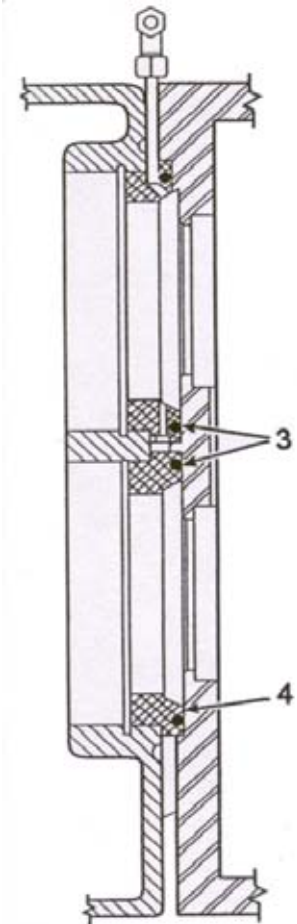

# MODELS R4, R4RI, R6 AND R6RI

## WATER FLUSH SEAL KIT OPTION-TOP FEED PUMPS R4, R4RI, R6, AND R6RI

-	WATER FLUSH SEAL KIT - includes items 1-4 listed below	-	M03WP239428
1	TEE - Brass - 3/16 in. x 1/8 in.	2	M568S6907A
2	TUBING - Copper - 3/16 in. O.D.	3 ft	M746S1855
3	PLUG - Locating - water flush seal	2	M03HP218225
4	O-RING (Pkg. of 10)	2	M543S131422
-	INSTRUCTION - PIPING WATER FLUSH SEAL	-	M03XP239428

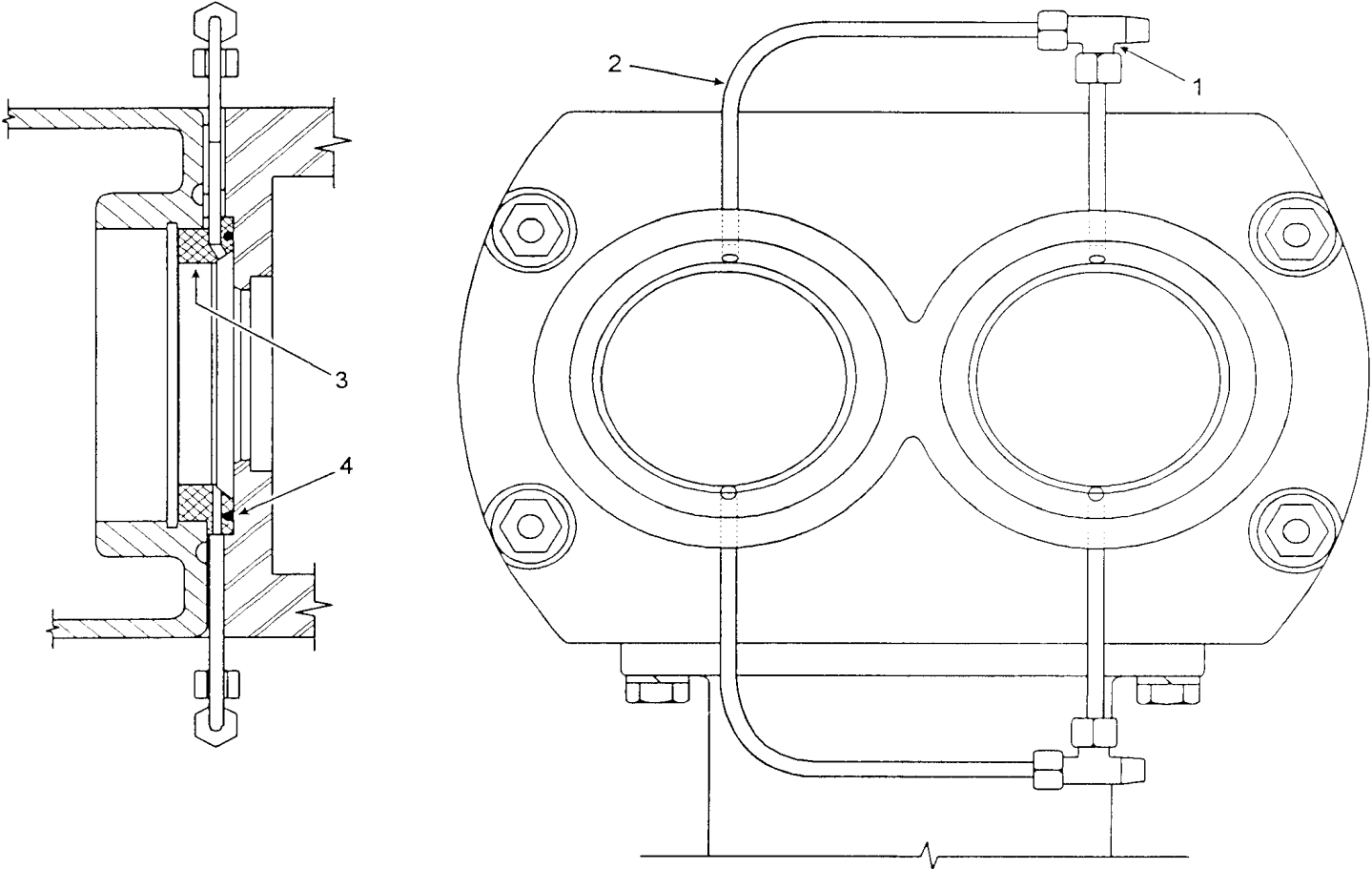

## MODELS R4HD, R6HD AND R700HD

### WATER FLUSH SEAL KIT OPTION - R4HD, R6HD: M03W-P-388662

ITEM	DESCRIPTION	PART NO.	QTY.
1	PLUG - Locating	M03H-P-218225	2
2	O-RING (Pkg. of 5)	*M543-S-1314-22	2
3	SEAL - Shaft	M03H-P-149370	2
4	O-RING (Pkg. Of 10)	*M543-S-1314-02	2
5	COVER - For Vertical Flow Only	M03A-P-257405	1
5	COVER - For Horizontal Flow Only	M03A-P-257405	1
6	CARTRIDGE	M03H-P-257717	2
7	TUBING - Copper - 1/4 in. O.D.	M746-S-1867	-
8	TEE - 1/4 in. x 1/8 in. - Male Run - No. 4SB12-B	M568-S6907-B	1
9	TUBING - Copper - 3/16 in. O.D.	M746-S-1855	-
10	TEE - 3/16 in. x 1/8 in.	M568-S-H938-B	2
11	TEE - 1/4 in. x 1/8 in. - Male Branch - No. 4SB12-B	M568-6907-C	1
-	INSTRUCTION - PIPING WATER FLUSH SEAL	M03XP388662	1

\*NOTE: Certain items are packaged in minimum quantity lots as indicated.

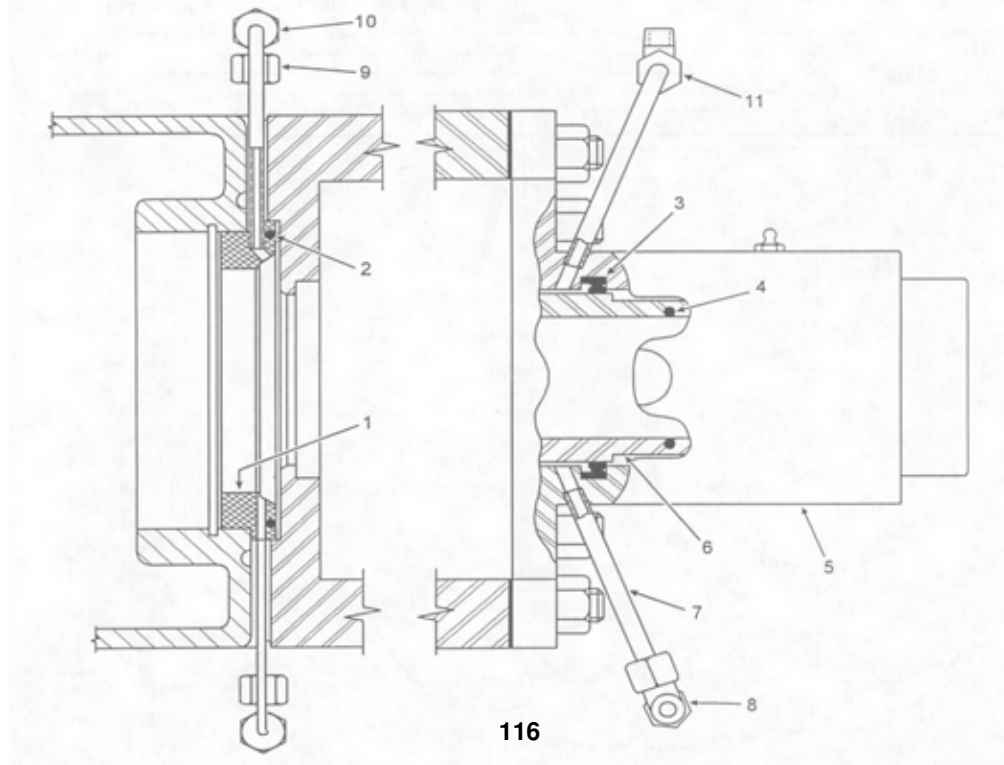

## MODELS R4HD, R6HD AND R700HD

**R700: M03W-P-382500: R700 HD TOP FEED: M03W-P-257486: R700RI: M03W-P-388863**

ITEM	DESCRIPTION	TYPE	PART NO.	QTY.
1	RING - Seal (Pkg. of 5)	R700	*M03H-P-137738	2
2	O-RING (Pkg. of 10)	R700	*M543-S-1314-05	2
3	SEAL	R700	M543-SK-608	2
4	BEARING - Seal	R700	M03H-P-137734	2
5	SEAL - Shaft (Pkg. of 10)	R700	*M03H-P-149370	4
6	O-RING (Pkg. of 5)	R700	*M543-S-1313-49	2
7	O-RING (Pkg. of 5)	R700	*M543-S-1313-51	2
8	CARTRIDGE - Rear Seal	R700	M03H-P-257381	2
9	PLUG - Locating	R700	M03H-P-257380	2
10	O-RING (Pkg. of 10)	R700	*M543-S-1314-02	2
11	COVER	R700	M03A-P-257405	1
12	FITTING - Grease	R700	M569-S-6394-C	2
13	CARTRIDGE - Front Seal	R700	M03H-P-257717	2
14	TEE - 1/4 in. x 1/8 in. - Male Branch - No. 4SB12-B	R700	M568-S-6907-C	2
15	TUBING - Copper - 1/4 in. O.D.	R700	M746-S-1867	-
16	TEE - 1/4 in. x 1/8 in. - Male Branch - No. 4SB12-B	R700	M568-S-6907-B	2

\*NOTE: Certain items are packaged in minimum quantity lots as indicated.

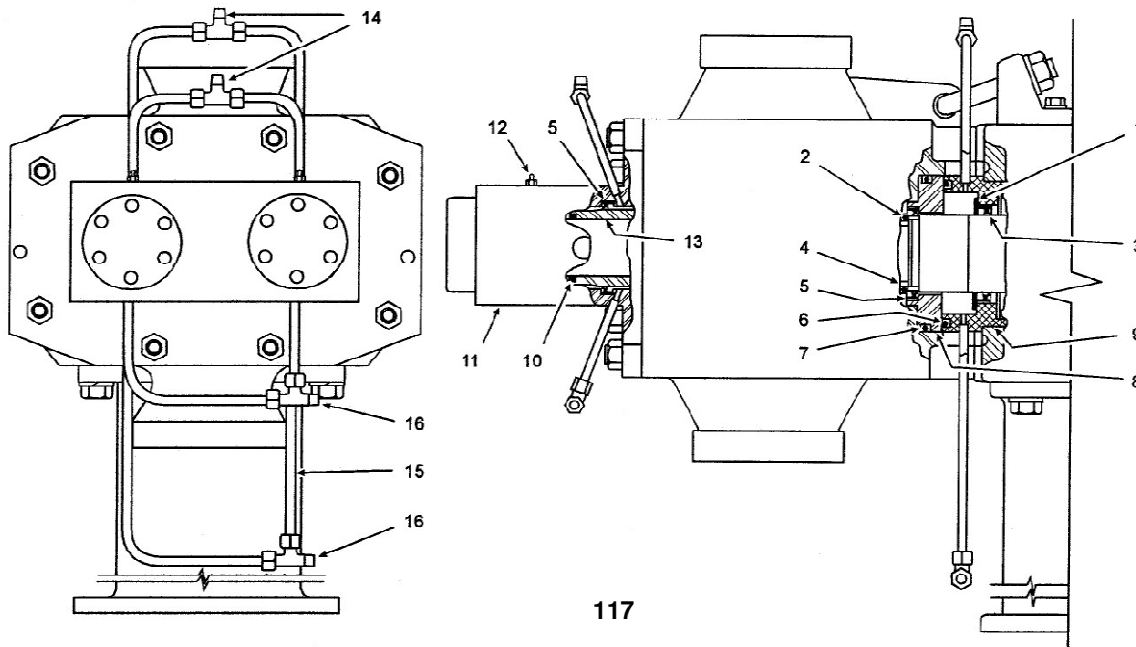



## HEAVY DUTY COVER SEAL OPTIONS

### STD HEAVY DUTY COVER R4HD, R6HD, R700HD

ITEM	DESCRIPTION	QTY.	PART NO.
			R4HD, R6HD, R700HD
1	CAP - Bearing End, Heavy-Duty	2	M03HP225266
2	SCREW	2	M521P229095
3	WASHER	2	M523V008819
4	PLATE & PIN (RETAINING WASHER)	2	M03AP225267
5	BEARING ASSEMBLY - Outboard Complete *	2	M03AP232733
(5A)	Outer race	(2)	M621S8184B
(5B)	Inner Race	(2)	M03HP255661
6	RING - Retainer	2	M03HP225033
10	CARTRIDGE - Front Seal & Spacer - std. HD cover	2	M03HP280219
11	O-RING (I.D. of cartridge) (Sold in pks of 10)	2	M543S131402
12	O-RING (I.D. of seal ring) (sold in pks of 10)	4	M543S131405
13	BEARING - Seal (Stainless Steel)	4	M03HP137734
14	SEAL - Shaft (Sold in pks of 10)	4	See Shaft Seals

\* Include items 5A and 5B

### HEAVY DUTY COVER - DEAERATOR/DEGASSER OPTION

ITEM	DESCRIPTION	QTY.	PART NO.
			R4HD, R6HD, R700HD
1	CAP - Bearing End, Heavy-Duty	2	M03HP225266
2	SCREW	2	M521P229095
3	WASHER	2	M523V008819
4	PLATE & PIN (RETAINING WASHER)	2	M03AP225267
5	BEARING ASSEMBLY - Outboard Complete *	2	M03AP232733
(5A)	Outer race	(2)	M621S8184B
(5B)	Inner Race	(2)	M03HP255661
6	RING - Retainer	2	M03HP225033
10	CARTRIDGE - Front Seal & Spacer DEAERATOR/DEGASSER cover option	2	M03HP232854
11	O-RING (I.D. of cartridge) (Sold in pks of 10)	4	M543S131402
12	O-RING (I.D. of seal ring)	-	N/A
13	BEARING - Seal (Stainless Steel)	-	N/A
14	SEAL - Shaft (Sold in pks of 10)	4	See Shaft Seals

\* Include items 5A and 5B

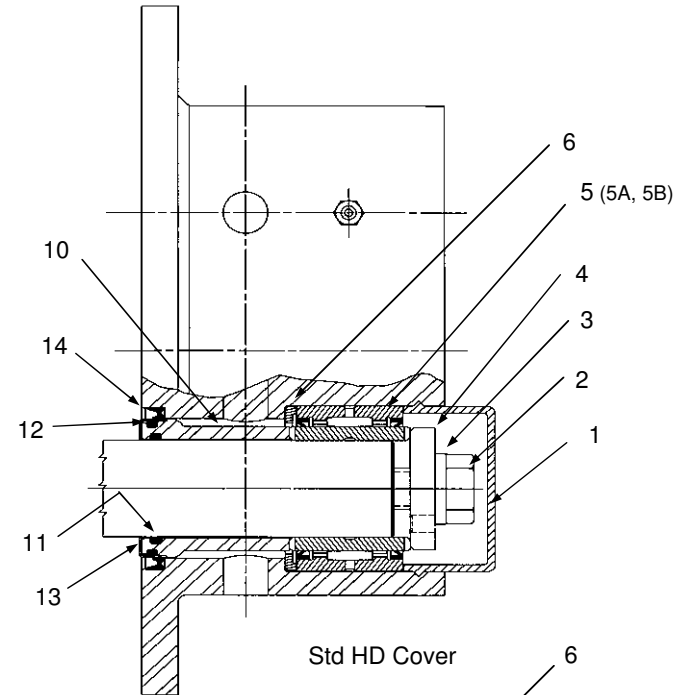

Std HD Cover

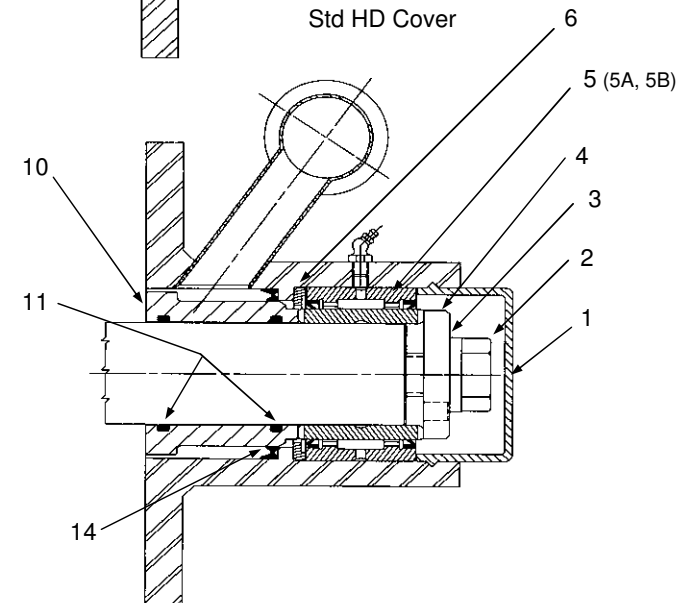

Deaerator/Degasser  
HD Cover

## HEAVY DUTY COVER SEAL OPTIONS

### HEAVY DUTY COVER - WATER FLUSH SEAL OPTION

ITEM	DESCRIPTION	QTY.	PART NO.
			R4HD, R6HD, R700HD
1	CAP - Bearing End, Heavy-Duty	2	M03HP225266
2	SCREW	2	M521P229095
3	WASHER	2	M523V008819
4	PLATE & PIN (RETAINING WASHER)	2	M03AP225267
5	BEARING ASSEMBLY - Outboard Complete *	2	M03AP232733
(5A)	Outer race	(2)	M621S8184B
(5B)	Inner Race	(2)	M03HP255661
6	RING - Retainer	2	M03HP225033
10	CARTRIDGE - Front Seal & Spacer - Waterflush Seal cover option	2	M03HP257717
11	O-RING (I.D. of cartridge) (Sold pks of 10)	4	M543S131402
12	O-RING (I.D. of seal ring) (Sold pks of 10)	4	M543S131405
13	BEARING - Seal (Stainless Steel)	4	M03HP137734
14	SEAL - Shaft (Sold pks of 10)	4	See Shaft Seals

\* Include items 5A and 5B

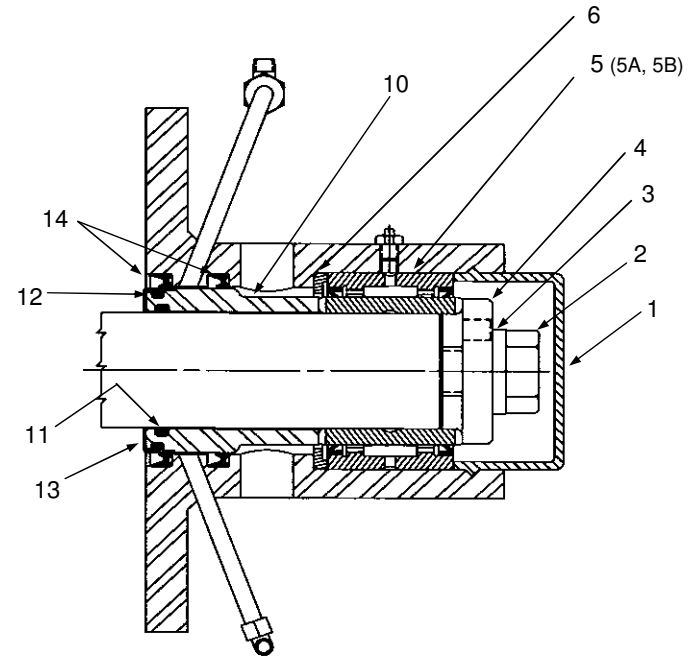

Water flush seal  
HD Cover

## MODEL R PUMP - SHAFT SEALS

Model	Type	Material			
		Nitrile (Standard) Red Dot	EPDM Two Orange Dot	Viton Blue Dot	Neoprene Green Dot
R0	Pressure / Vacuum	M03H-P-331054	M03H-P-331055	M03H-P-331053	N/A
R1	Pressure / Vacuum	M03H-P-203252	M03H-P-203253	M03H-P-203251	M03H-P-151261
	Pressure	M03H-P-203262	M03H-P-203262	M03H-P-203261	M03HP171623
	Pressure / Vacuum Heavy Duty	M03H-P-411045	M03H-P-411046	N/A	N/A
R2, R2RI	Pressure / Vacuum	M03H-P-203252	M03HP203253	M03H-P-203251	M03HP203261
	Pressure	M03H-P-203262	M03H-P-203263	M03HP203261	M03HP171623
	Pressure / Vacuum Heavy Duty	M03H-P-411045	M03H-P-411046	N/A	N/A
R3, R3RI, R3HDRI	Pressure / Vacuum	M03H-P-203232	M03H-P-203233	M03H-P-203231	M03H-P-149531
	Pressure	M03H-P-203242	M03H-P-203243	M03H-P-203241	M03H-P-203460
	Pressure / Vacuum Heavy Duty	M03H-P-411050	M03H-P-411051	N/A	N/A
R4, R4RI, R4HD, R4HDRI	Pressure / Vacuum	M03H-P-203212	M03H-P-203213	M03H-P-203211	M03H-P-149370
	Pressure	M03H-P-203222	M03H-P-203223	M03H-P-203221	M03H-P-171624
	Pressure / Vacuum Heavy Duty	M03H-P-411055	M03H-P-411056	M03H-P-411057	N/A
R6, R6RI, R6HD, R6HDRI	Pressure / Vacuum	M03H-P-203212	M03H-P-203213	M03H-P-203211	M03H-P-149370
	Pressure	M03H-P-203222	M03H-P-203223	M03H-P-203221	M03H-P-171624
	Pressure / Vacuum Heavy Duty	M03H-P-411055	M03H-P-411056	M03H-P-411057	N/A
R700HD, R700HDRI	Pressure / Vacuum	M03H-P-203212	M03H-P-203213	M03H-P-203211	M03H-P-149370
	Pressure	M03H-P-203222	M03H-P-203223	M03H-P-203221	M03H-P-171624
	Pressure / Vacuum Heavy Duty	M03H-P-411055	M03H-P-411056	M03H-P-411057	N/A

Refer to instruction manual for recommendation on seal materials.

Note:

R1 and R2 models have same shaft seals.

R4,R6 and R700 models have same shaft seals.

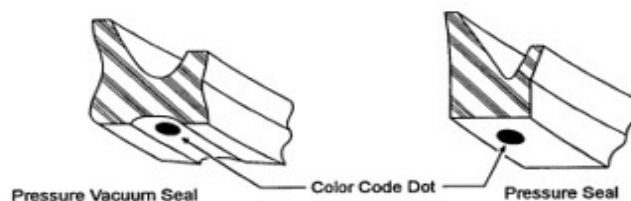

## ROTORS

Pump Size	Hub	Face	Nitrile Covered Rotors				
			Recommended Operation Temperature Range				
			TO 100 F (37 C) Oversize +0510	TO 150 F (65 C) Standard Size	TO 200 F (93 C) Undersize 0510	TO 250 F (121C) Undersize 1025	TO 300 F (149C) Undersize 1540
R0 2 LOBE STD	316 ss	flush	N/A	M03SS353910	M03SS353911	M03SS353912	N/A
R0 5 LOBE	316 SS	flush	N/A	M03SS475256	M03SS475257	M03SS475258	N/A
R1	316 SS	recessed	N/A	M03SS151267	M03SS177243	M03SS177245	N/A
R1	316 SS	flush	M03SS331652	M03SS331647	N/A	N/A	N/A
R2	316 SS	recessed	N/A	M03SS137712	M03SS177252	M03SS177254	N/A
R2	316 SS	flush	M03SS189277	M03SS189270	M03SS189272	M03SS189274	N/A
R3	316 SS	recessed	M03SS428545	M03SS428546	M03SS428547	M03SS428548	N/A
R3	316 SS	flush	M03SS428570	M03SS428571	M03SS428572	M03SS428573	N/A
R3	epoxy	recessed	M03HP248320	M03HP248321	M03HP428322	M03HP428323	N/A
R3	epoxy	flush	M03HP428355	M03HP428356	M03HP428357	M03HP428358	N/A
R4, R4HD	316ss	recessed	M03SS420140	M03SS420141	M03SS420142	M03SS420143	N/A
R4, R4HD	316 SS	flush	M03SS428325	M03SS428326	M03SS428327	M03SS428328	N/A
R 4, R4HD	epoxy	recessed	M03HP420180	M03HP420181	M03HP420182	M03HP420183	N/A
R6, 700 single lobe	316 SS	recessed	N/A	M03HP239839	M03HP239843	M03HP167834	N/A
R6, R6HD, R700 HD	316SS	recessed	M03HP420145	M03AP420146	M03AP420147	M03AP420149	N/A
R6,R6HD, R700 HD	316SS	recessed	M03SA420145	M03SA420146	M03SA420147	M03SA420148	N/A
R6, R6HD, R700 HD	316 SS	flush	M03SA420185	M03SA420186	M03SA420187	M03SA420188	N/A

\*\*\*\*MODEL 700 PUMPS REQUIRE 4 ROTORS PER PUMP\*\*\*\*

## ROTORS

			EPDM Covered Rotors				
			Recommended Operation Temperature Range				
Pump Size	Hub	Face	TO 100 F (37 C) Oversize +0510	TO 150 F (65 C) Standard Size	TO 200 F (93 C) Undersize 0510	TO 250 F (121C) Undersize 1025	TO 300 F (149C) Undersize 1540
R0	316 SS	flush	N/A	N/A	N/A	N/A	N/A
R1	316SS	recessed	N/A	N/A	N/A	N/A	N/A
R1	316 SS	flush	N/A	N/A	N/A	N/A	N/A
R2	316 SS	recessed	N/A	M03SS331657	M03SS331654	M03SS331656	M03SS331658
R3	316SS	recessed	M03SS442625	M03SS442626	M03SS442627	M03SS442628	M03SS442629
R3	316 SS	flush	M03SS465735	M03SS465736	M03SS465737	M03SS465738	M03SS465739
R3	epoxy	recessed	M03HP442125	M03HP442126	M03HP442127	M03HP442128	M03HP442129
R4, R4HD	316 SS	recessed	M03SS442630	M03SS442631	M03SS442632	M03SS442633	M03SS442634
R6, 700 single lobe	316 SS	recessed	M03HP475980	M03HP475981	M03HP475982	M03HP475983	M03HP475984
R6, R6HD, R700 HD	316SS	recessed	M03HP442635	M03HP442636	M03HP442637	M03HP442638	M03HP442639
R6, R6HD, R700 HD	316 SS	recessed	M03SA442635	M03SA442636	M03SA442637	M03SA442638	M03SA442639
R6, R6HD, R700 HD	316 SS	flush	M03SA465745	M03SA465746	M03SA465747	M03SA465748	M03SA465749
			HNBR Covered Rotors				
			Recommended Operation Temperature Range				
Pump Size	Hub	Face	TO 100 F (37 C) Oversize +0510	TO 150 F (65 C) Standard Size	TO 200 F (93 C) Undersize 0510	TO 250 F (121C) Undersize 1025	TO 300 F (149C) Undersize 1540
R0 2 Lobe std	316 SS	flush	N/A	M03SS469161	M03SS469162	M03SS469163	M03SS469164
R0 5 Lobe	316ss	flush	N/A	M03SS492580	N/A	N/A	N/A
R1	316 SS	recessed	M03SS469180	M03SS469181	M03SS469182	M03SS469183	M03SS469184
R2	316 SS	recessed	M03SS469190	M03SS469191	M03SS469192	M03SS469193	M03SS469194
R3	316 SS	recessed	M03SS478210	M03SS478211	M03SS478212	M03SS478213	M03SS478214
R4, R4HD	316 SS	recessed	M03SS478215	M03SS478216	M03SS478217	M03SS478218	M03SS478219
R6, R6HD, R700 HD	316 SS	recessed	M03SA478220	M03SA478221	M03SA478222	M03SA478223	M03SA478224
R6, 700 single lobe	316 SS	recessed	M03HP478225	M03HP478226	M03HP478227	M03HP478228	M03HP478229

## ROTORS

Viton Covered Rotors							
Recommended Operation Temperature Range							
			TO 100 F (37 C)	TO 150 F (65 C)	TO 200 F (93 C)	TO 250 F (121C)	TO 300 F (149C)
Pump Size	Hub	Face	Oversize +0510	Standard Size	Undersize 0510	Undersize 1025	Undersize 1540
R0 2 Lobe std	316SS	flush	N/A	M03SS469001	M03SS469002	M03SS469003	N/A
R0 5 Lobe	316SS	flush	N/A	M03SS442440	M03SS830511	N/A	N/A
R1	316SS	recessed	M03SS408285	M03SS408286	M03SS408287	M03SS408288	M03SS408289
R1	316SS	flush	M03SS469020	M03SS469021	M03SS469022	M03SS469023	M03SS469024

Pump Size	Solid Celcon Flush Face	
	Standard Size TO 135 F (57 C)	0510 Undersize TO 180 F (82 C)
R0	N/A	N/A
R1	M03HP408336	M03HP408337
R2	M03HP475441	M03HP475442
R3	M03HP465721	M03HP465722
R4	N/A	N/A
R6	N/A	N/A

Pump Size	Solid Epoxy
	TO 200 F (93 C)
R0	N/A
R1	N/A
R2	N/A
R3	M03HP385221
R4	M03HP382819
R6	M03HP361928

ONLY AVAIABLE IN SHOWN MODELS

## ROTORS

Pump Size	5 Lobe Metal Rotor Options					
	Flush Face					
	5 Lobe Metal Rotor - Nitronic 60 SS No wear rings	5 Lobe Metal Rotor Nitronic 60 SS (*)	Wear Ring PPS Plastic (4 per pump)	Wear Ring Teflon (4 per pump)	Wear Ring- Waukesha 2000 (4 per pump)	Spacer Ring (R700HD only)
R0	N/A	M03HP469120	M03HP478420	M03HP475230	N/A	N/A
R1	N/A	M03HP469122	M03HP478421	N/A	N/A	N/A
R2	N/A	M03HP469123	M03HP478421	N/A	N/A	N/A
R3	M03HP475003	M03HP469125	M03HP478422	M543P397041	N/A	N/A
R4, R4HD	M03HP475004	M03HP469126	M03HP478423	M543P420051	M03HP486304	N/A
R6, R6HD	M03HP475006	M03HP469127	M03HP478423	M543P420051	M03HP486304	N/A
R700 HD	M03HP475006	M03HP469127	M03HP478423	M543P420051	M03HP486304	M03HP478242

(\*) With wear ring grooves. Pump models R0-R6 require 2 rotors and 4 wear rings per pump.  
R700HD pump models require 4 rotors, 4 wear rings and 2 spacer rings per pump.

## ROTORS

		Metal Rotor Options - 2 Lobe - Bow Tie				
		Flush Face				
Pump Size	2 Lobe Bow Tie Metal Rotor - Nitronic 60 SS No wear rings	2 Lobe Bow Tie Metal Rotor Nitronic 60 SS (*)	Wear Ring PPS Plastic (4 per pump)	Wear Ring Teflon (4 per pump)	Wear Ring-Waukesha 2000 (4 per pump)	Spacer Ring (R700HD only)
R0, R1, R2, R3	N/A	N/A	N/A	N/A	N/A	N/A
R4, R4HD	M03HP475004	M03HP481484	M03HP478423	M543P420051	M03HP486304	N/A
R6, R6HD	M03HP475006	M03HP481486	M03HP478423	M543P420051	M03HP486304	N/A
R700 HD	M03HP475006	M03HP481486	03HP478423	M543P420051	M03HP486304	M03HP478242

(\*) With wear ring grooves. Pump models R0-R6 require 2 rotors and 4 wear rings per pump.  
R700HD pump models require 4 rotors, 4 wear rings and 2 spacer rings per pump.

		Stainless Steel Hub/Nitrile Covered Rotors - JT Profile					
		Recessed (Standard) Face					
Pump Size	Hub	Face	TO 100 F (37 C) Oversize +0510	TO 150 F (65 C) Standard Size	TO 200 F (93 C) Undersize 0510	TO 250 F (121C) Undersize 1025	TO 300 F (149C) Undersize 1540
R1 (JT)	316 SS	recessed	M03SS420120	M03SS420121	M03SS420122	M03SS420123	M03SS420124
R2 (JT)	316 SS	recessed	M03SS420125	M03SS420126	M03SS420127	M03SS420128	M03SS420129
R3 (JT)	316 SS	recessed	M03SS475200	M03SS475201	M03SS475202	M03SS475203	M03SS475204

NOTE: JT Rotors have tighter tolerances and are intended for metering pump applications.



## TOOLS FOR ALL MODEL R SERIES PUMPS

TOOLS	Qty	MODEL					
		R0	R1/R2	R3	R3HD	R4/R6	R700HD
1 SPANNER WRENCH	1	N/A	M689S4177	M689S4178	M689S4178	M689S4178	M689S4178
2 ROTOR PULLER WRENCH (not HD pumps)	1	N/A	N/A	M03HP133586	N/A	M03HP133613	N/A
3 T-HANDLE WRENCH	1	N/A	M747P133540	N/A	N/A	N/A	N/A
4 ROTOR PULLER - R0	1	M03AP367535	N/A	N/A	N/A	N/A	N/A
5 SEAL INSERTER	1	M03AP353666	M03AP286719	M03AP286600	M03AP286600	M03AP286752	M03AP286752
6 ROTOR PULLER - SOLID PLASTIC ROTOR	1	N/A	N/A	M03AP395466	M03AP395466	M03AP385820	N/A
7 ROTOR PULLER - 3 PRONG	1	N/A	M03AP188155	M03AP225667	M03AP225667	N/A	N/A
8 HEAVY DUTY ROTOR PULLER (HD pumps only)	1	N/A	N/A	N/A	N/A	M03AP250898	M03AP221079
9 REPLACEMENT FINGER KIT - includes finger, spacer and 3 screws	1	N/A	N/A	N/A	N/A	M03WP221081	M03WP221081

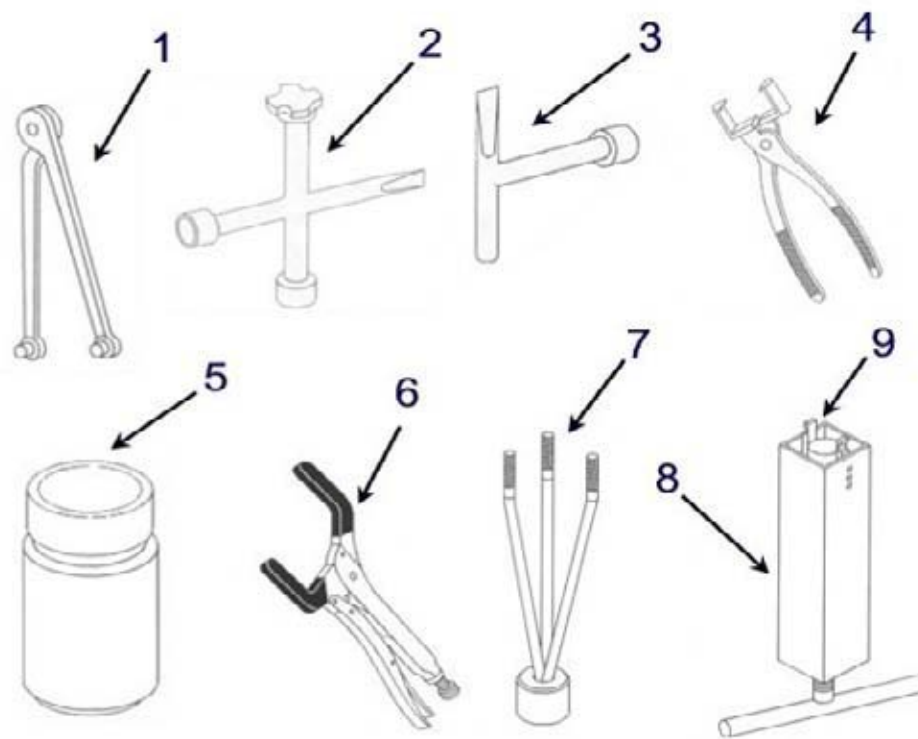

# R SERIES PUMPS - RECOMMENDED INVENTORY

Class I Duty - Suggested for domestic service and where some interruption in service is possible.  
Supplies typical service part usage for 6 months or 1000 hours of service.

Class II Duty - Suggested for export service or for domestic service where minimum loss of service is essential.  
Supplies typical service part usage for 1 year or 2000 hours.

Order by part number, not by item number.

Spare Parts are supplied with each pump, including some parts listed below.  
Those items included are identified with ( ) and the quantity following the part description.

Description		Quantity	
		Class I	Class II
<b>Gear Case Parts</b>			
BEARING - Front - Tapered Roller	All	N/A	2
BEARING - Rear - Tapered Roller	All	N/A	2
BEARING Cover (R4HD, R6HD and R700HD models only)	R4HD, 6HD, 700HD	N/A	2
GASKET - Gear Case	All	1	1
O-RING - Rear Bearing Seal	All	10*	10*
SEAL - Front Oil	All	2	2
SEAL - Rear Oil	All	1	1
SHAFT & GEAR ASSEMBLY - Long	All	N/A	1
SHAFT & GEAR ASSEMBLY - Short	All	N/A	1
<b>Product Contact Parts</b>			
BEARING - Seal	All	4	8
BUSHING - HD Shaft (3HDRI only)	3HD, 3HDRI only	20*	20*
O-RING - Pump Seal (2)	All	10*	20
ROTOR (Per Sold Order)	All	4	4
SEAL - Shaft (Per Sold Order) (2)	All	10*	20
GASKET - Cover (Paper) (100)	all but R0	100	200
GASKET - Cover (O-ring)	R0 & R's w/oring option	10*	20
O-RING - Front Cartridge	R4HD, R6HD & R700HD	10*	20
O-RING - Rear Cartridge (R700 only)	R700HD only	10*	20
<b>Options (add only if option was selected)</b>			
WEAR RING - Solid Metal Rotor	metal rotor option	10	20
SPACER RING - Solid Metal Rotor	R700HD only	2	4
GASKET - Rectangular Inlet	RI models	2	4
GASKET - Rectangular Cover (Paper) (In Place of Standard)	RI models	100*	200
DEAERATOR/DEGASSER CARTRIDGE - Front (R700 only)	R700HD only	2	N/A
WATER FLUSH CARTRIDGE - Front (R700 only)	R700HD only	N/A	2
O-RING - Waterflush	water flush seal option	10	20

\*Number listed represents minimum order quantity





APV, An SPX Brand  
611 Sugar Creek Road  
Delavan, WI 53115  
Phone: (888) 278-4321  
Email: [answers.us@apv.com](mailto:answers.us@apv.com)

For more information about our worldwide locations, approvals, certifications, and local representatives, please visit [www.apv.com](http://www.apv.com).

SPX Corporation reserves the right to incorporate our latest design and material changes without notice or obligation. Design features, materials of construction and dimensional data, as described in this bulletin, are provided for your information only and should not be relied upon unless confirmed in writing.

Issued: 04/2009 03WP469240-I

Copyright © 2008 SPX Corporation

