

# "ITM-4" 4-Beam Turbidity Meter

## Introduction

The Anderson-Negele ITM-4 Turbidity meter offers precision measurement of suspended solids through the use of infrared light. Utilizing a 4-beam technology the ITM-4 has multiple emitters and receptors to produce an online, real-time measurement of turbidity that can yield information critical to both process function and product quality. The compact integral design makes installation and set-up easy. But this simplicity in design does not mean that the ITM-4 is short on features. There are standard switching and analog (4-20mA) outputs along with 4 remote selectable ranges that are available to handle different products on the same process line.

Specifying the ITM-4 is easy with the line connection size as the only decision that needs to be made. Configuration is done with a simple three button navigation of the on-screen menus that makes selecting units of measure, analog output range, and switch point for your product a quick task. Most important to food and dairy processors is the robust design which offers lower cost of ownership than many other turbidity meters. The LED lamp technology provides longer life than devices utilizing tungsten bulbs and a sapphire lens is resistant to damage commonly found on other lens materials. Since this unit employs multiple beams, fouling of the optics is compensated automatically which significantly reduces the need for servicing. Most importantly the construction is the same rugged watertight stainless steel construction you have come to expect from Anderson-Negele. In fact the unit complies to the German IP69K standard which is more stringent than NEMA 4X. Whether the application involves alarming a process when signs of premature filtration failure occur or to provide constant feedback on a solids concentration to ensure product quality, the ITM-4 offers the needed performance and durability to give years of trouble free operation.

For more information on this turbidity meter, or any of our Anderson-Negele Instrument Products visit [www.anderson-negele.com](http://www.anderson-negele.com) or call our customer service department at 1-800-833-0081

## Authorizations



## Features

- 3-A Compliant; Third party verified in accordance with standard 46-03
- 4-20 mA plus switch output
- 4 Remote selectable ranges
- Ranges from 0-5 NTU to 0-5000 NTU
- 2 units (NTU and EBC) 11 ranges each

## Applications

- Whey/tower water monitoring
- Chill water monitoring
- Filter monitoring
- Yeast monitoring/dosing
- Quality control
- Waste water control

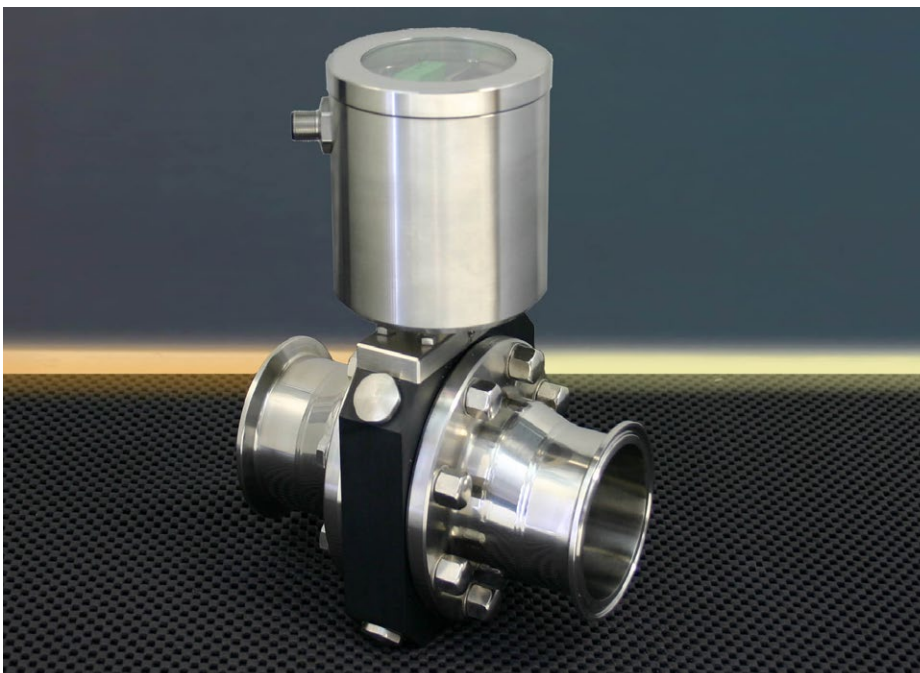

**Specifications**

Process Connection: 1.5", 2", 2.5", 3"  
 Installation: 5 pipe diameters before and 2 after instrument

**MATERIALS**  
 Connection Head: SS 1.4305 (303 Stainless)  
 89 mm dia.  
 Fitting: SS 1.4404 (316L)  
 Optical Block: PEEK  
 Lens: Sapphire

**TEMPERATURE RANGES**  
 Ambient: -10-60 °C (14-140°F)  
 Process: 0-100 °C (32-212°F)  
 CIP/SIP-Cleaning: up to 130 °C (266°F)  
 Operating Pressure: 145 psi maximum  
 Measurement Principle: acc. to EN 7027 4-beam-altern. light  
 Wave Length: acc. to EN 7027 860 nm ± 60 nm  
 LCD-Indicator with Illumination: 2 x 8-digit  
 Accuracy: see table below  
 Electr. Connection: Cable Entry: 2 x PG (M16 x 1.5)  
 Cable Connection: 2 x M12 plug-in(SS 316), (1) 4 pin, (1) 5 pin  
 Supply Voltage: 24 VDC (18-36 V DC) 160 mA maximum

**INPUT**  
 Input Range Switching: E1 and E2 24 VDC (18-36 V DC) DC decoupled Output  
 Analog: 4-20 mA active  
 Short Circuit Proof: DC decoupled  
 Switching: 24 VDC 80 mA maximum respectively to GND of power supply

**MEASUREMENT RANGES**  
 NTU: 0-5; 10; 20; 50; 100; 200; 500; 1000; 2000; 4000; 5000  
 EBC: 0-1; 2; 5; 10; 20; 50; 100; 200; 500; 1000; 1250  
 Damping Time: 0; 1; 2; 4; 8; 16; 32; 64; 128 seconds (adjustable)

**APPROVALS**  
 ETL Listed  
 Conforms to UL Std 61010-1 3rd Ed (with Display option B only)  
 Certified to CSA Std C22.2 61010-1 3rd Ed (with Display option B only)

**ENVIRONMENTAL**  
 Enclosure Protection: Design and tested to IP69k; intended for use in wet environments at up to 100% relative humidity

**Total length of fitting (tol.: ±5/64")**

Process connection / nominal width	Tri-Clamp@(-TC) acc. to DIN32676
1.5"	11.33"
2"	8.86"
2.5"	6.75"
3"	6.61"

Accuracy	at the calibration points (20; 200; 2000 NTU)		± 2%
Offset drift			< ± 0.3NTU (± 0.075EBC)
Slope accuracy	Range 0-1000 NTU	(0-250 EBC)	< 3 %
	Range 1001-2000 NTU	(250-500 EBC)	< 4 %
	Range 2001-5000 NTU	(500-1250 EBC)	< 6 %
Reproducibility	Range 0-1000 NTU	(0-250 EBC)	< 2 %
	Range 1001-2000 NTU	(250-500 EBC)	< 3 %
	Range 2001-5000 NTU	(500-1250 EBC)	< 4 %
Resolution	Range 0-100 NTU	(0-25 EBC)	0.1 NTU (0.025 EBC)
	Range 100-1000 NTU	(25-250 EBC)	1 NTU (0.25 EBC)
	Range 1001-5000 NTU	(250-1250 EBC)	10 NTU (2.5 EBC)

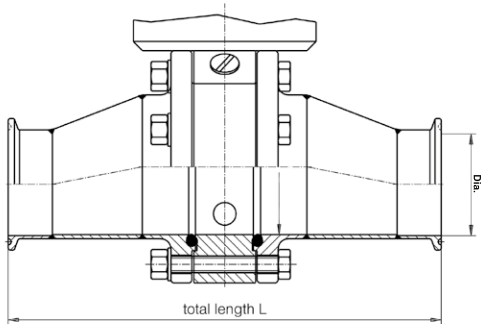

The following conditions must be met in order for the ITM-4 to comply with 3-A standard 46-03:

- The sensor must be mounted in a position that ensures it will be self-draining.

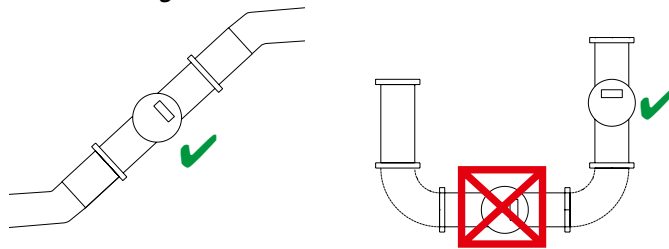

**Order Information**

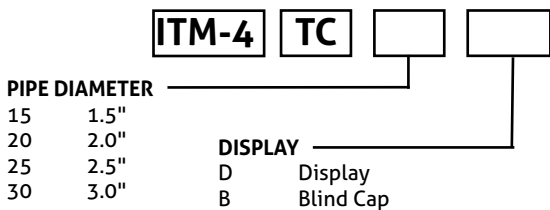

**Accessories**

Shielded cordset w/25' cable	42117H0025
Shielded cordset w/50' cable	42117H0050
Shielded cordset w/100' cable	42117H0100
Field Wireable Connector-Straight	42119B0000
Field Wireable Connector-90°	42119A0000