

M-159 & M-750 SERIES

HOT & COLD WATER MIXING STATIONS WITH HOSE RACK

These hot and cold systems enable the operator to manually regulate water temperature as necessary for the wash down application. The standard models, M-159 and M-750, provide independent control of water for wash down applications where water temperature is non-critical. For applications where the water temperature is crucial, the M-159TG and M-750TG are equipped with a dial-type temperature gauge (TG) that indicates the wash water's exact temperature in both Celsius and Fahrenheit, and a specially designed internal blending chamber that efficiently blends hot and cold water.

The M-159 is Bronze and the M-750 is Stainless Steel. All models are equipped with a solid Stainless Steel hose rack for convenient storage. Available options for all units are:

- Wall Mounted - globe, ball, and angle valve entry
- Recessed Wall Box Units - globe and angle valve entry
- Pedestal Units - globe, ball, and angle valve entry

FLOW TEST			
WATER PRESSURE PSI	FLOW (GPM)		
	W/OUT NOZZLE	WITH M-70, S-70 SERIES & HYDRO-PRO 150 NOZZLES	WITH M-70, S-70 SERIES & HYDRO-PRO 150 LOW FLOW NOZZLES
20	4.5	3 ¼	2 ¼
30	5.4	4 ¼	2 ¾
40	6.2	5 ½	3 ¼
50	6.8	5 ¾	3 ¾
60	7.4	6 ¾	4 ½
70	8.2	7 ½	4 ¾
80	8.6	7 ¾	4 ¾
90	9.3	8 ¼	5
100	9.8	9	5 ½

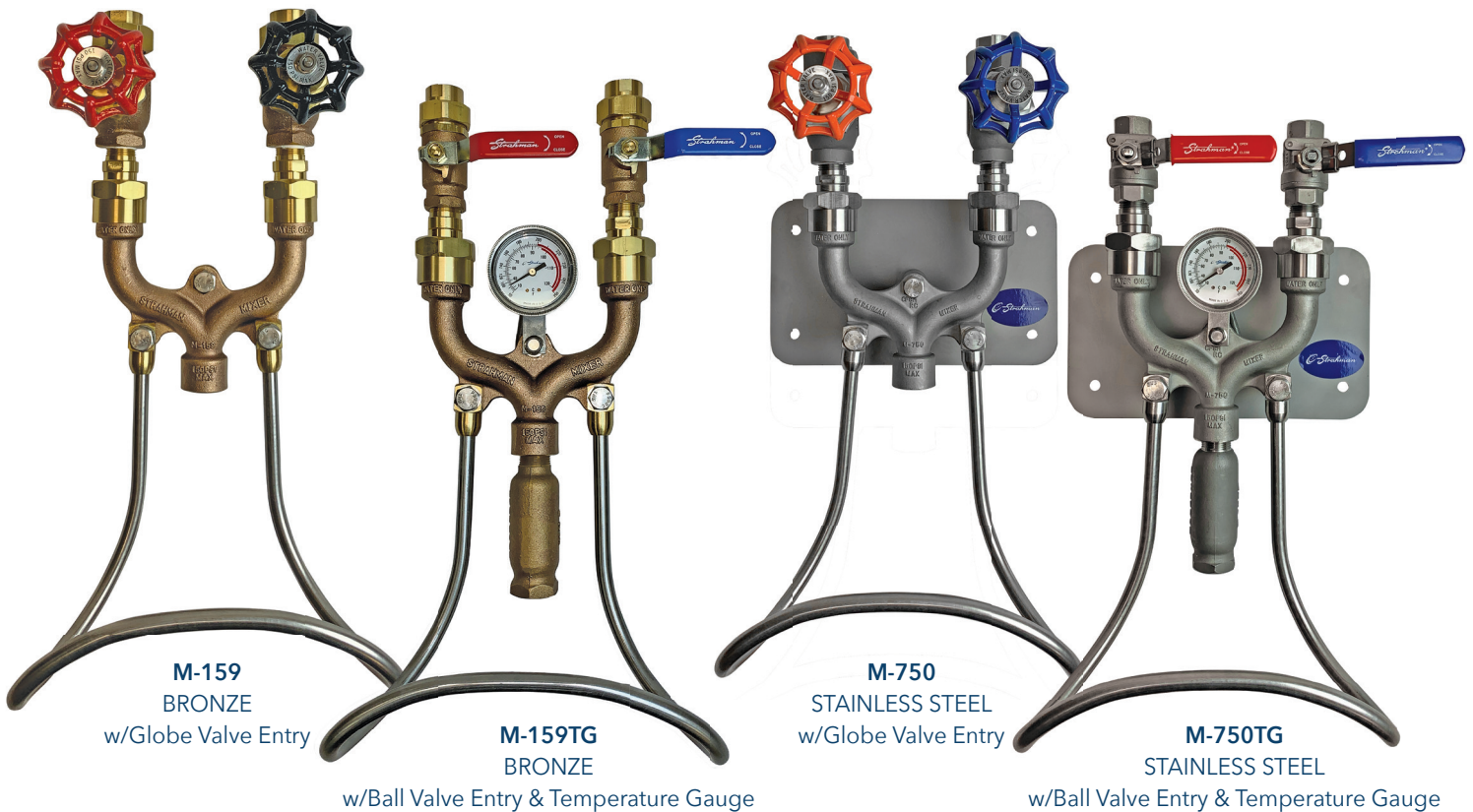

Maximum water temperature: 200°F (93°C)
Maximum working pressure range: 150 psi

ALSO AVAILABLE WITH ADDITIONAL AIR-LINE VERSION

If unit is exposed to freezing temperatures, draining or heat tracing is required.

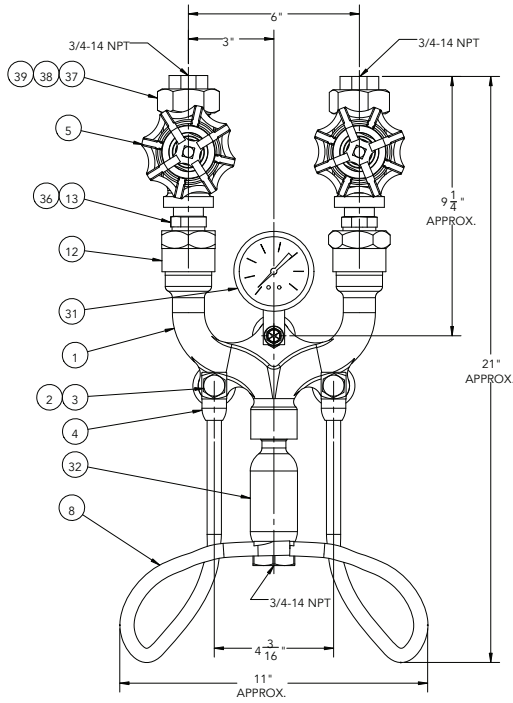
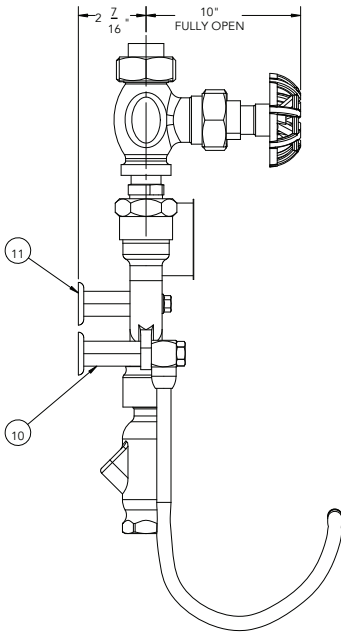

GLOBE VALVE ENTRY

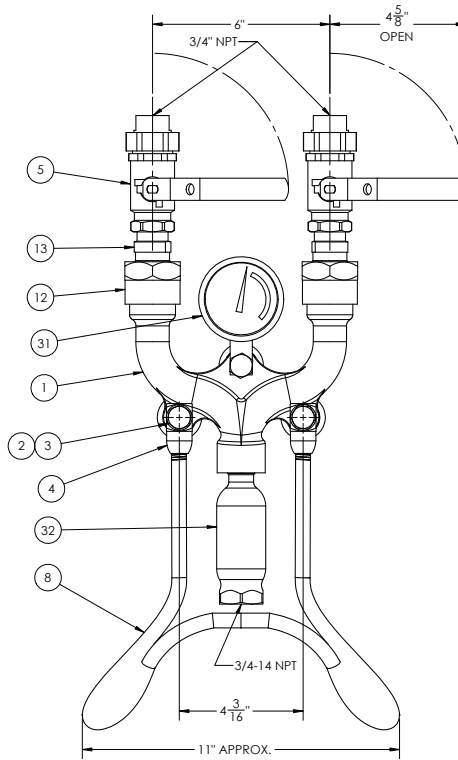
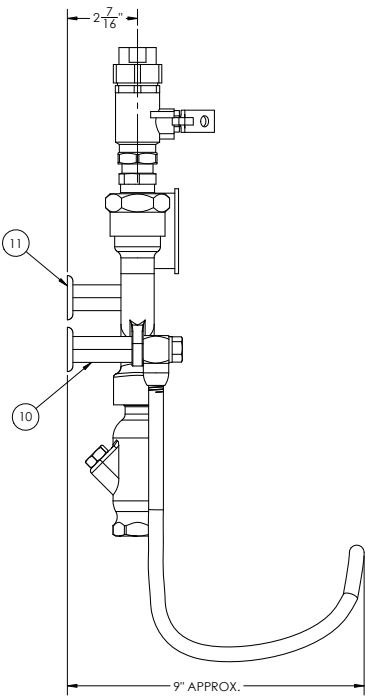

BALL VALVE ENTRY

ITEM NO.	DESCRIPTION	M-159 BRONZE ORDER NO. (MATERIAL)	M-750 STAINLESS STEEL ORDER NO. (MATERIAL)
MAIN BODY PARTS LIST			
1	BODY	MD159BDFBR (ASTM CA386)	M750BDFSS (ASTM 316 SS, A351 CF8M)
2	CAP SCREW (SET OF 6)	HH0050130200OZ (SST304, ASTM A276)	HH0050130200OZ (SST304, ASTM A276)
3	LOCK WASHER (SET OF 6)	WAT0050 (SST410)	WAT0050 (SST410)
4	HOSE RACK CONNECTOR	HRCONBR (ASTM B16 C36000)	HRCONSS (ASTM A582 303)
5	GLOBE VALVE	SEE CATALOG	SEE CATALOG
	BALL VALVE	SEE CATALOG	SEE CATALOG
8	HOSE RACK WITH FITTINGS	HRCOMPLETE0000 (SST304, ASTM A276)	HRCOMPLETE0002 (SST304, ASTM A276)
10	HEX SPACER	MUSPAC (SST416, ASTM A582)	HRSPACSS (SST416, ASTM A582)
11	WALL PLATE (OPTIONAL)	MUWPLTBR (BRASS B16, CA360)	THIS IS STANDARD ON THIS UNIT (SST304, ASTM A240)
12	BALL CHECK UNION NUT	BCNUTBR (BRASS ASTM B16 C36000)	BCNUTSS (SST304, ASTM A276)
13	BALL CHECK VALVE	BCBRG (BRASS ASTM B16, C36000, SST303, ASTM A582)	BCSSG (SST304, ASTM A276, SST303, ASTM A582)
31	TEMPERATURE GAUGE	TGGF02 (BRASS B283, CA37700)	TGGF02 (BRASS B283, CA37700)
32	BLENDING CHAMBER	BLCHMFB (BRASS BRONZE B62, CH83600)	BLCHMFSS (SST303, ASTM A351)
36	BALL CHECK VALVE GASKET	BCGAC (COPPER)	BCGA (COPPER, PTFE)
37	INLET UNION NUT	GVUNUTBR (BRASS B16, C36000)	GVUNUTSS (303SS, ASTM A582)
38	UNION TAIL PIECE	GVUTAILBR (BRASS B16, C36000)	GVUTAILSS (304SS, ASTM A276, UNS-S3040)
39	SPIRAL WOUND UNION GASKET (SET OF 6)	GVGA (PTFE)	GASW015001000063MA (304SS, C4)

WDEM159M750SER012020