

We UVCare...



# Application Optimized UV for Pharmaceuticals

**RODEM**<sup>®</sup>  
SMART SANITARY PROCESSES

[www.Rodem.com](http://www.Rodem.com) | (800) 543-7312

**PHARMALINE PQ AF H**

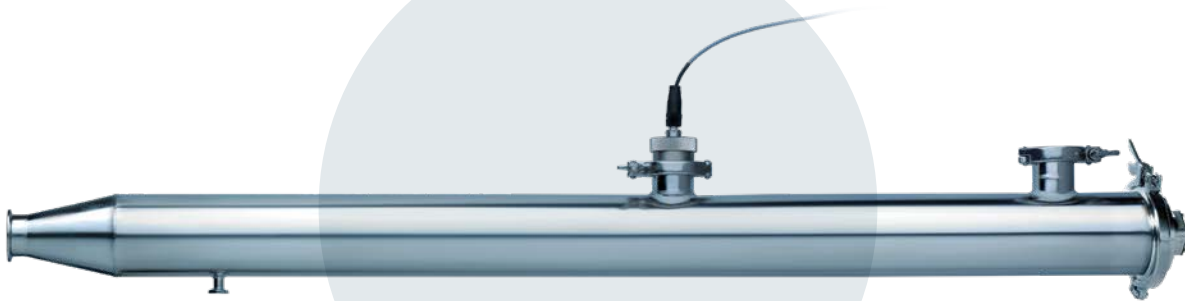

Bioassayed UV  
disinfection for Purified  
Water and distribution  
(Hygienic Design-H)

Our PharmaLine PQ AF H systems are designed for hygiene based on cGMP principles and aimed specifically at providing third party bioassayed UV disinfection in Pharmaceutical Purified Water Generation and distribution loop systems where sanitary design is critical. By using a third party bioassayed UV system you can be certain that the UV dose being produced will disinfect the water, eliminate objectionable organisms, reduce the bio-burden, protect against bio-fouling, lead to fewer CIP / SIP cycles and lower operating costs. Each system comes with a certified dry UV sensor and UVGuard™ sensor window allowing easy checking of UV performance while the system continues to operate. The UV sensor measures the germicidal output of the UV system and an RED dose read out makes it easy to monitor and log performance. The systems all use low pressure amalgam lamps providing an energy efficient germicidal wavelength, long lamp life to reduce operating costs and can be easily installed to existing processes. The control system also has the ability to take flow and transmittance meter inputs and calculate the UV dose based on real time operating conditions.

**berson**

**hanovia**

**aquionics**

# Potential locations of the PharmaLine PQ AF H™

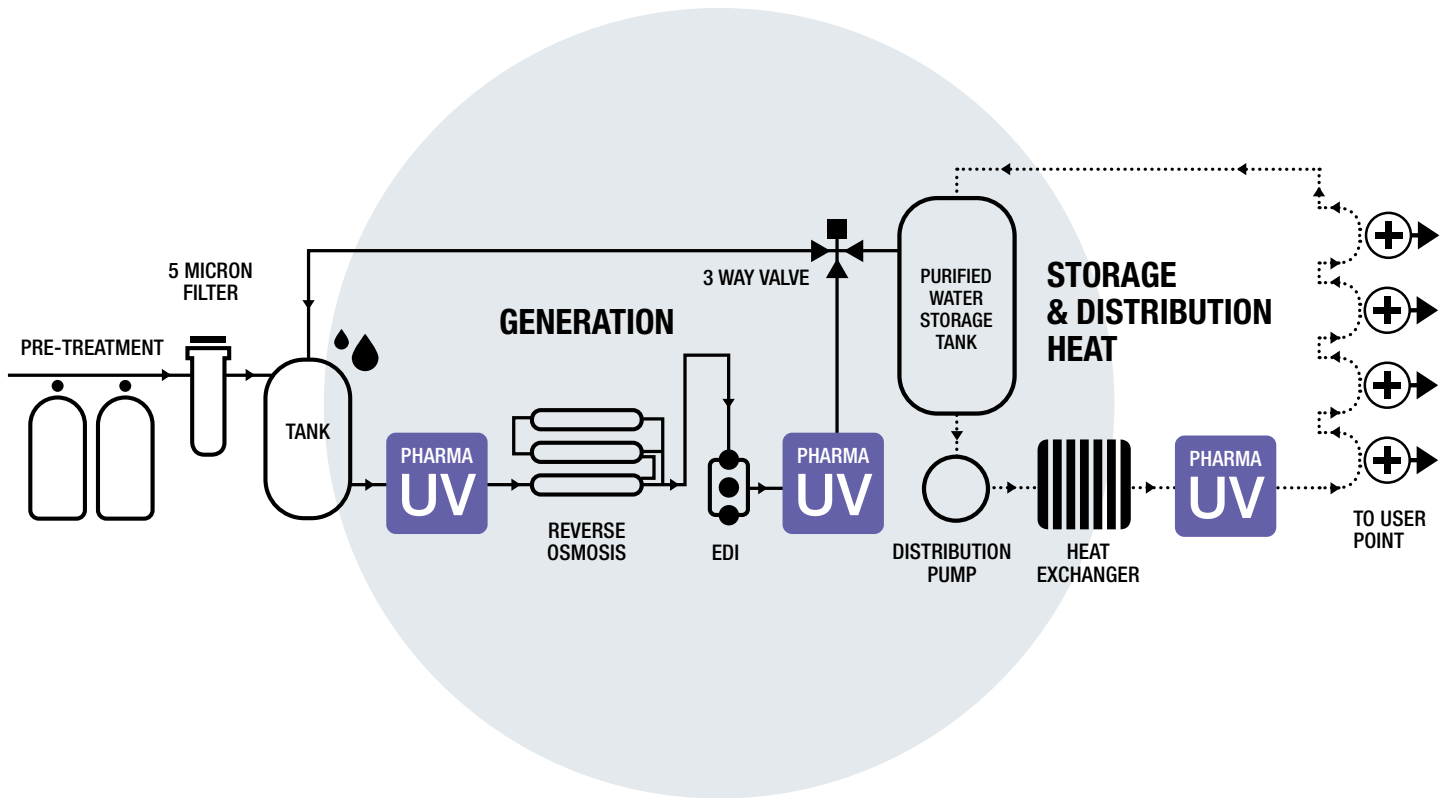

KEY FEATURES	WHAT IT GIVES YOU	BENEFITS FOR YOU
<b>INTELLIGENCE</b>		
Dry DVGW approved UV sensor measuring germicidal wavelengths	Continuous verification of performance with real time RED dose reading and in-built low dose warning	Easy to monitor and log system performance
UVGuard™ on UV sensor window	Protects against UV exposure when checking a UV duty sensor with a reference sensor while the system is operating	Ability to safely audit the UV performance without interrupting production
UVShield™ on chamber*	Indication of lamp on. Power cut out on lamp access. Ability to add water leak detection	UV lamp status on chamber. Enhanced safety for lamp access. Ability to add water leak detection
Flow and UV transmittance (UVT) meter inputs	Dose reading based on actual process conditions when meters are connected	Accurate UV dose reading guaranteed under wide range of operating conditions
Option of using a transmittance compensating third party dose equation	Ability to calculate RED dose compensating for changes in transmittance without a transmittance meter	Accurate UV dose reading guaranteed under wide range of operating conditions without adding a UV transmittance meter
<b>OPTIMIZATION</b>		
Third party validated UV systems tested in accordance with the USEPA UV Disinfection Guidance Manual	UV system dose equations and sizing have been independently derived	Confidence the system will perform as stated
Single low pressure amalgam lamp technology (LPHO)	Targeted microbiological wavelength	Proven log reduction of microorganisms as part of a multi-barrier purified water process Reduced bio-burden in distribution loops leading to fewer CIP / SIP cycles and optimised production efficiency Protects RO membranes from bio-fouling, reducing CIP frequency and downtime
Designed for the pharmaceutical industry based on cGMP principles	Sanitary design with <0.38 µm internal surface finish and tri-clamp connections as standard FDA-approved materials used for all wetted parts	Industry compliance; reduced risk of microbiological contamination; enhances control of your process as part of a multi-barrier system
<b>INTEGRATION</b>		
Compact design	Can be fitted to skids Can be retrofitted to existing process	Easy integration
RS 485 Modbus	Single cable connection to customer control system	

\*Optional

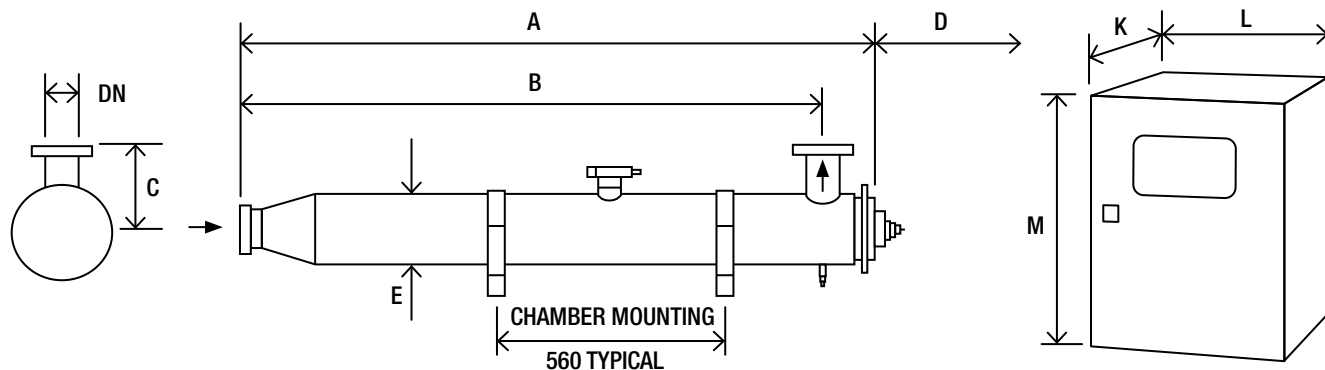

PharmaLine PQ AF H (low pressure amalgam lamp)			Dimensions (inches)									Approx weight (lb)	
Model	Maximum Power (W)	UVT (%)	A	B	C	D	E	DN***	K*	L	M**	Chamber (Empty)	Control Cabinet
PharmaLine PQ AF H 0005	125	60	54.6	50.1	3.2	51.2	4	1.5	8.8	23.6	35	20	79
PharmaLine PQ AF H 0008	200	60	54.6	50.1	3.2	51.2	4	2	8.8	23.6	35	20	79
PharmaLine PQ AF H 0016	350	60	54.6	50.1	3.2	51.2	4	2	8.8	23.6	35	20	79
PharmaLine PQ AF H 0030	350	60	56.6	51.2	5.9	51.2	6.6	3	8.8	23.6	35	53	79
PharmaLine PQ AF H 0090	750	60	78	71.9	7.9	74.8	8.1	6	8.8	23.6	35	101	79

\* Allow dimension L in front of cabinet for door opening and panel access.

\*\* M dimension includes the space for the cabinet mounting brackets but you need to allow space below the cabinet for cable entry and access (minimum of 9.8").

\*\*\* DN tri-clamp sizes over 3" may not fit with standard sanitary tube. Please consult with Aquionics for correct dimensions.

All dimensions are approximate for clearance purposes only. We have a policy of continuous product development, exact drawings are available on request. All specifications are subject to change without notification. Your distributor or our account manager can advise on correct sizing and specification requirements.

UV CHAMBER	
Material:	StSt 316L / 1.4404
Internal finish:	<0.38 µm Ra, welds left as laid, electropolished and passivated
External finish:	Sateen polish (120 grit) electropolished and passivated
Process (mating) connections:	Tri-clamp. For sizes see <a href="#">Tri-clamp technical bulletin 910425-0001</a>
Drain connection:	Tri-clamp to ISO 2852
End plate:	Removable tri-clamp
Degree of protection:	IP65 equivalent to NEMA 4 but not for outside use
UV lamp:	Low pressure amalgam
Quartz sleeve:	Pure quartz (F200)
Number of UV lamps:	1
Expected lamp life:	12000 hours
Temperature sensor:	Yes
UV sensor:	Dry DVGW compliant UV sensor with UVGuard™ window
Working fluid temperature:	41°F to 104°F
Maximum CIP temperature:	266°F (PQ AF H 0005 – PQ AF H 0016) 203°F (PQ AF H 0030 – PQ AF H 0090) with cabinet electrically isolated
Hydrostatically pressure tested:	Yes
Chamber mounting:	Horizontal only
Operating pressure:	10 bar (positive pressure only)
Seals:	EPDM, FDA 21 CFR 177.2600, USP Class VI 250°F approved

OPTIONS	
Transmittance compensating dose equation	
Document Support Pack	
Cabinet material: Stainless steel 304	
Automatic wiper (pneumatic)	
Operation and Maintenance manual and printed Installation and Commissioning manual in Chinese, English, French, German and Spanish	
Lead length: 65.6 ft & 95.1 ft PQ AF H 0005 - 0008, 46 ft PQ AF H 0016 - 0090	
Maximum CIP temperature: 266°F (PQ AF H0030 – PQ AF H0090, panel switched off)	
UL Listing	
UL 508A panel shop	
UVShield™	
Water leak detection	

OPTIONS (CONTINUED)	
In-field UV reference sensor kit	
Welder Document Pack for chamber construction	
Bleed: Hygienic valve with tri-clamp connection	
Skid mounting (not ship board or earthquake zone)	
CABINET (CONTROLLER UVTRONIC)	
Material:	Polyester coated carbon steel
Degree of protection:	IP66 / NEMA 4
Supply voltages:	230 V (+/-10%), 50/60 Hz
Operating temperature range:	41°F to 104°F
Relative humidity:	<95% non-condensing
Cooling fans:	No
Interconnecting cable lengths:	32 ft
Variable power:	Stepless variable power on PQ AF H 0090 only (40% reduction from max ballast power, 20% dose reduction)

HMI / CONTROL	
Display:	4 line LCD, indicating system status including alarms
Operating menu:	3 levels with password protection
Fault finding:	Event log

CUSTOMER OUTPUTS	
4-20 mA passive outputs:	UV dose and UV intensity
24 V dc 10 mA max outputs:	Lamp ON, any trip, any warning, system ready, system in remote, bleed valve

CUSTOMER INPUTS	
4-20 mA active or passive:	Flow meter and transmittance meter
VFC inputs:	Remote stop/start and remote reset

CUSTOMER COMMUNICATIONS PORT	
RS 485:	Modbus

APPROVALS	
CE marked	



## PHARMALINE PQ AF H

Also available in our Pharmaceutical product range...



### PHARMALINE DC

Chlorine removal



### PHARMALINE D+DH

Disinfection as part  
of a multi barrier approach or  
secondary maintenance



### PHARMALINE DO

Ozone removal and disinfection



**berson**



**hanovia**



**aquionics**

[www.weuvcare.com](http://www.weuvcare.com)

BERSON, HANOVIA & AQUIONICS WORKING TOGETHER AS PART OF THE HALMA GROUP.

#### Netherlands

t: +31 40 2907777  
e: sales@bersonuv.com

#### China

t: +86 21 61679599  
e: china@hanovia.com

#### USA

t: +1 980 256 5700  
e: sales@aquionics.com

#### Germany

t: +49 800 5892779  
e: verkauf@hanovia.com

#### Malaysia

t: +60 16 440 8834  
e: asia@hanovia.com

#### Canada

t: +1 980.256.5700  
e: sales@aquionics.com

#### United Kingdom

t: +44 1753 515300  
e: sales@hanovia.com

#### Mexico

t: +1 980.256.5700  
e: sales@aquionics.com



A **Halma** company