

Crystallizer - Outdoor Lactose - 091486

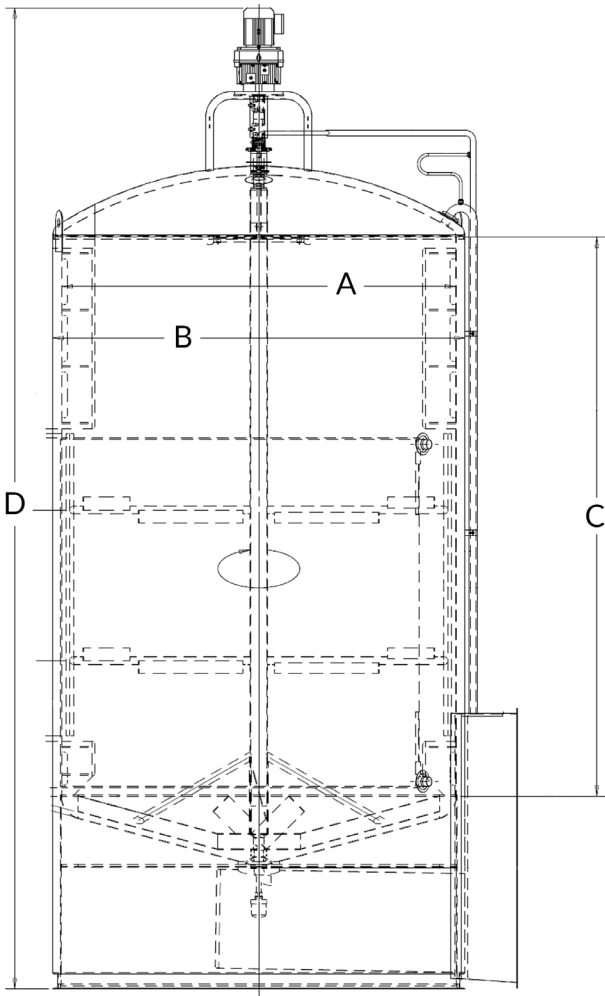

U.S. GALLONS	A (ID)	B (OD)	C (SS)	D (OAH)	WEIGHT (LBS)
5000	107.75	114.5	120	288	9500
5000	107.75	114.5	144	312	10,000
10,000	120	126.75	199	374	12,000
10,000	132	138.75	162	334	13,400
12,000	132	138.75	198	370	14,800
15,000	144	150.75	204	378	15,800
20,000	144	150.75	276	450	19,800

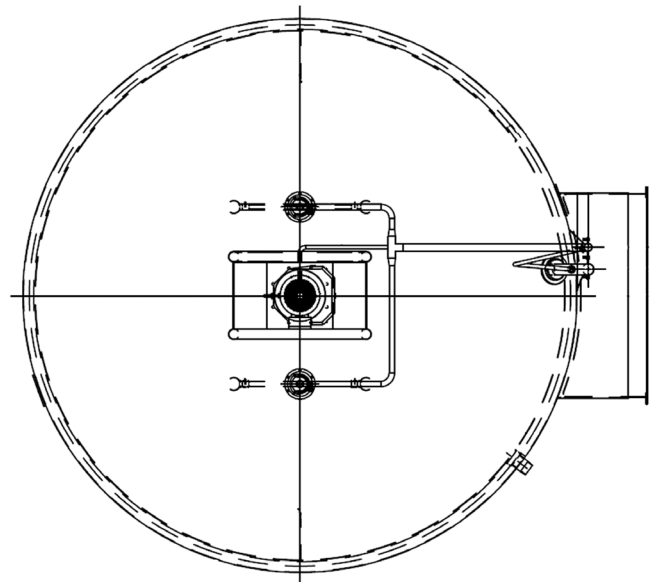

Additional notes:

- Product Contact: 304L Stainless w/ 32 Ra Finish
- Exterior: Carbon Steel w/ White Urethane Paint
- Alcove w/ tunnel access to outlet valve
- Heat Transfer (1) zone on sidewall
- 3" Fiberglass insulation on top & bottom head
- 3" EPS insulation on sidewall
- Side & Bottom Sweep agitator w/ pushers & pullers
- Agitator baffles included as needed
- Designed for 1.3 SG, 1,000 CPS max
- Tank is atmospheric rated
- Built to 3A standards

Nozzle Schedule Includes:

- 16" x 20" Manway w/ sample
- 2" Inlet
- 3" Outlet Valve
- Agitator Fitting
- Level Gauge Sleeve
- Indicating Thermowell w/ 5" dial thermometer
- Recording Thermowell
- 3" Vent/Overflow Line
- 2" CIP Line
- (2) CIP T-ball assembly
- Heat Transfer Connections

Optional Items:

- Product Contact: other alloys & finishes available
- Non-Product Contact: other alloys & finishes available
- Alcove available in various sizes
- Insulations available for higher temperatures
- Heat tapes and insulation for lines



DCI, Inc.
600 North 54th Ave
St. Cloud, MN 56303
Phone: 320-252-8200
www.dciinc.com



Stay up to date with everything DCI, Inc.!



07/08/19 Rev-0