

Dynamixer

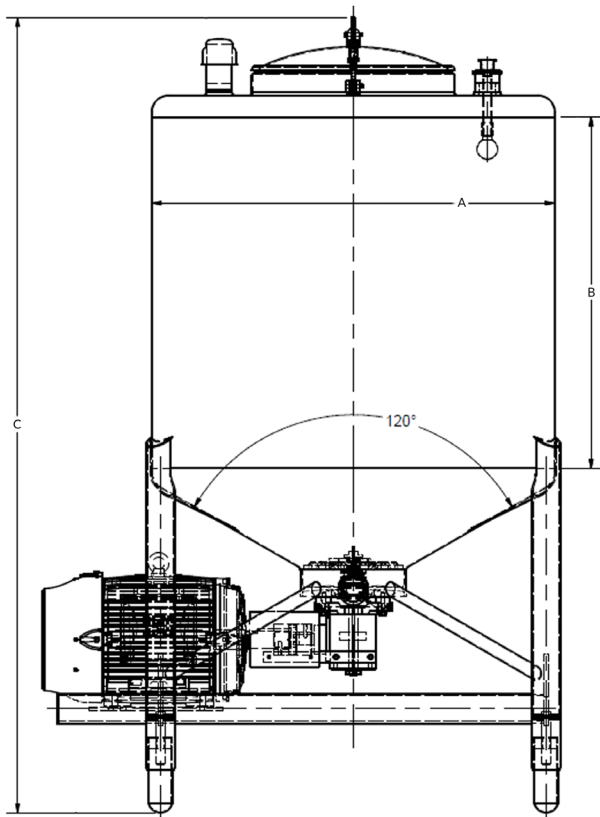

U.S. GALLONS	A (I.S.)	B (SS)	C OAH	WEIGHT (LBS)
25	27	8	50.25	400
50	27	17	59.25	430
100	40	16	61	1030
200	40	30	75.5	1100
300	40	45	90.5	1220
400	48	42	95.25	1350



SINGLE CUP



SINGLE CUP WITH CHOPPERS



DOUBLE CUP

Nozzle Schedule Includes:

- 2" TC inlet
- 18" A-100 manway
- 3" TC maximum outlet 100 Gal & above, 2.5" for rest
- 3" TC CIP mount
- 1.5" TC CIP inlet
- 3" vent screen 100 Gal & above, 2" for rest
- 12" seal housing

Additional notes:

- 50,000 cp max through 500 gallon
- Includes single cup agitation
- Waterflushed seal standard
- (1) single sprayballs std
- 32 Ra ID, 40 Ra OD, BB legs
- 316L/316 product contact is std.
- Adjustable ball feet standard
- Seismic Zone 0 standard
- Tanks are atmospheric rated

Optional Items:

- Product Contact: other alloys & finishes available
- Non-Product Contact: other alloys & finishes available
- See images for available standard agitator options
- Heat transfer surface, dimple jacket or laser
- Insulation and sheathing
- Stainless ladder & platform
- Ask DCI, Inc. Sales for other options available

