



RODEM[®]

PROCESS EQUIPMENT

www.rodem.com 800-543-7312

Instruction Manual

Unique Mixproof CP-3

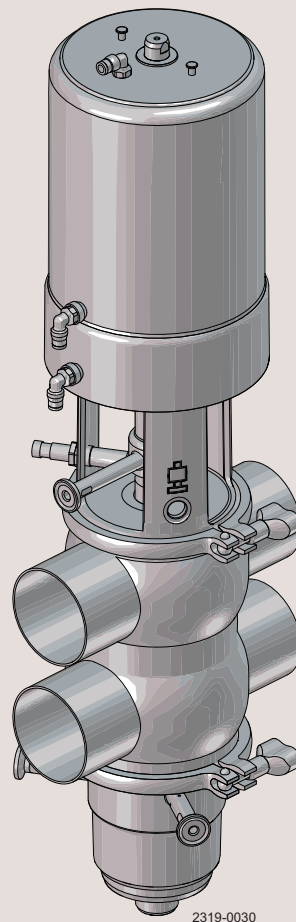

2319-0030

ESE02710-ENUS1

2014-05

Original manual

The information herein is correct at the time of issue but may be subject to change without prior notice

1. Introduction	5
2. Safety	6
2.1. Important information	6
2.2. Warning signs	6
2.3. Safety precautions	7
3. Installation	8
3.1. Unpacking/intermediate storage	8
3.2. Recycling	11
3.3. General installation	11
3.4. Welding	13
3.5. Pneumatic functions	14
3.6. Valve position indication	15
3.7. Adjustment of indication	16
3.8. Regulatory Inspection	18
3.9. Electrical connection chart	19
4. Operation	21
4.1. Operation	21
4.2. Recommended cleaning	22
4.3. Troubleshooting and repair	27
5. Automation	28
5.1. Specifications	28
5.2. Installation	34
5.3. Setup diagram	37
5.4. Maintenance	42
6. Maintenance	44
6.1. General maintenance	44
6.2. Dismantling of valve	45
6.3. Lower plug, replacement of radial seal	48
6.4. Upper plug, replacement of axial seal	51
6.5. Assembly of valve	53
6.6. Dismantling of actuator	58
6.7. Assembly of actuator	60
7. Technical data	63
7.1. Technical data	63
8. Parts list and service kits	64
8.1. Actuator	64
8.2. Plug setup overview	66
8.3. Plug setup 3	70
8.4. Plug setup 4	74
8.5. Plug setup 5	78
8.6. Plug setup 6	82
8.7. Plug setup 11	86
8.8. Plug setup 12	90
8.9. Plug setup 13	94
8.10. Plug setup 14	98

Table of contents

The information herein is correct at the time of issue but may be subject to change without prior notice

8.11.Plug setup 17	102
8.12.Plug setup 18	106
8.13.Plug setup 19	110
8.14.Plug setup 20	114
8.15.Valve body	118
8.16.Axial installation tool (upper plug)	120
8.17.Radial installation tool (lower plug)	121

Thank you for purchasing an Alfa Laval product.

This manual has been provided to instruct you in how to operate and service this product correctly and safely. Make sure that you follow all directions and instructions; failure to do so could result in personal injury or equipment damage.

This manual should be considered part of this product and should remain with it at all times for reference. (If you sell it, please be sure to include this manual with it.) Warranty is provided as part of Alfa Laval's commitment to our customers who operate and maintain their equipment as this manual dictates. Failure to do so may result in loss of warranty.

Where defects appear on the product during the warranty period, Alfa Laval will take back the product and correct the problem. Should the equipment be modified or not kept in the manner prescribed within this manual, the warranty will become null and void.

2 Safety

*Unsafe practices and other important information are emphasised in this manual.
Warnings are emphasised by means of special signs.*

2.1 Important information

Important information

Always read the manual before using the valve!

WARNING

Indicates that special procedures must be followed to avoid serious personal injury.

CAUTION

Indicates that special procedures must be followed to avoid damage to the valve.

NOTE

Indicates important information to simplify or clarify procedures.

2.2 Warning signs

General warning:



Caustic agents:



Cutting danger:



*Unsafe practices and other important information are emphasised in this manual.
Warnings are emphasised by means of special signs.*

2.3 Safety precautions

Installation:

Always read the technical data thoroughly (see section 7 Technical data) 



Always release compressed air after use

Never touch the clip assembly or the actuator piston rod if the actuator is supplied with compressed air (see warning label)

Never stick your fingers through the valve ports if the actuator is supplied with compressed air 

Operation:

Always read the technical data thoroughly (see section 7 Technical data)

Never touch the clip assembly or the actuator piston rod when the actuator is supplied with compressed air (see warning label)  

Never pressurise air connections (AC1, AC3) simultaneously as both valve plugs can be lifted (can cause mixing)

Never touch the valve or the pipelines when processing hot liquids or when sterilising.

Never throttle the leakage outlet

Never throttle the CIP outlet, if supplied

Always handle lye and acid with great care 

Maintenance:

Always read the technical data thoroughly (see section 7 Technical data) 

Always fit the seals correctly

Always release compressed air after use

Always remove the CIP connections, if supplied, before service.

Never service the valve when it is hot

Never pressurise the valve/actuator when the valve is serviced

Never stick your fingers through the valve ports if the actuator is supplied with compressed air

Never touch the clip assembly or the actuator piston rod if the actuator is supplied with compressed air (see warning label) 

Never service the valve with valve and pipelines under pressure

Transportation:

Always ensure that compressed air are released

Always ensure that all connections is disconnected before attempting to remove the valve from the installation

Always drain liquid from valves before transportation

Always used predesigned lifting points if defined

Always ensure sufficient fixing of the valve during transportation - if specially designed packaging material is available, it must be used

3 Installation

The instruction manual is part of the delivery.

Study the instructions carefully.

Fit the warning label supplied on the valve after installation so that it is clearly visible.

3.1 Unpacking/intermediate storage

Step 1

CAUTION!

Alfa Laval cannot be held responsible for incorrect unpacking.

Check the delivery for:

1. Complete valve
 2. Delivery note
 3. Warning label
-

Step 2

Remove upper support

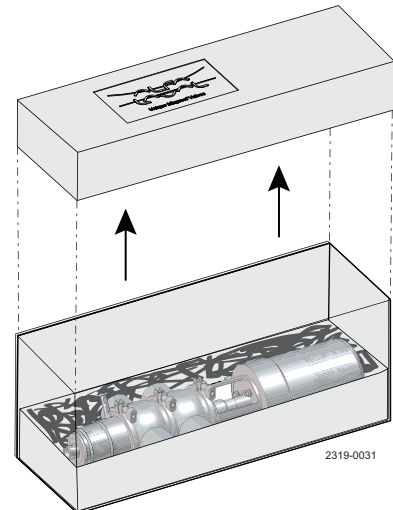

Step 3

Lift out the valve.

NOTE!

Please note weight of valve as printed on box.

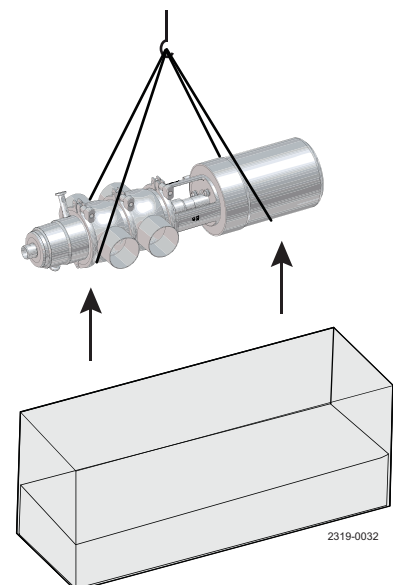

The instruction manual is part of the delivery.

Study the instructions carefully.

Fit the warning label supplied on the valve after installation so that it is clearly visible.

Step 4

Remove possible packing materials from the valve ports.

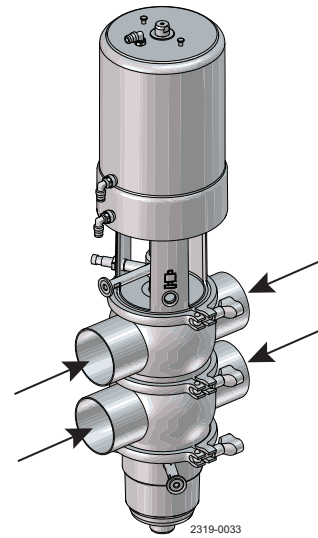

Step 5

Inspect the valve for visible transport damage.

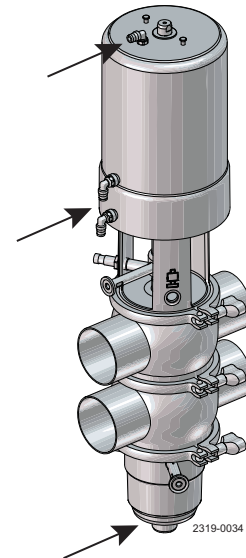

Step 6

Avoid damaging the air connections, the leakage outlet, the valve ports and the CIP connections.

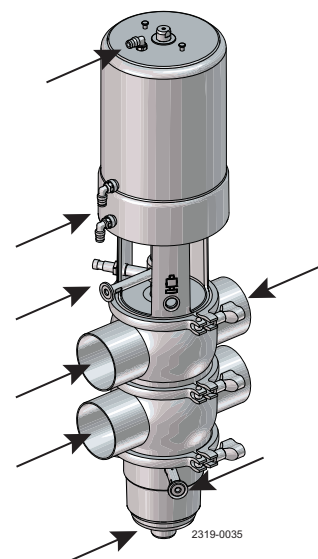

3 Installation

The instruction manual is part of the delivery.

Study the instructions carefully.

Fit the warning label supplied on the valve after installation so that it is clearly visible.

Step 7

Disassemble according to illustrations
(please also see 6.2 Dismantling of valve).

1. Supply compressed air.
2. Remove upper clamp (64).
3. Release compressed air.
4. Lift out actuator with plugs.

Compressed
air supply

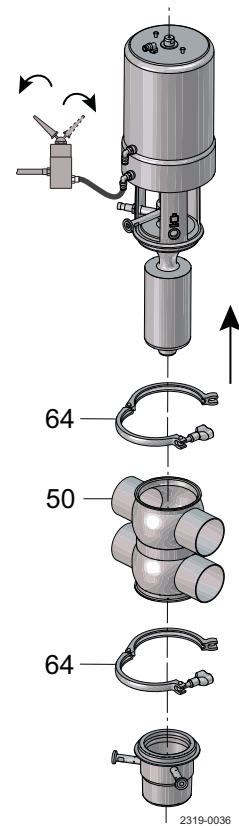

Step 8

While valve body is welded, it is recommended to store the valve safely in the box together with valve parts.

1. Place actuator and valve parts in the box.
2. Add supports.
3. Close, re-tape and store the box.

ADVICE!

Mark the valve body and box with the same number before intermediate storage.

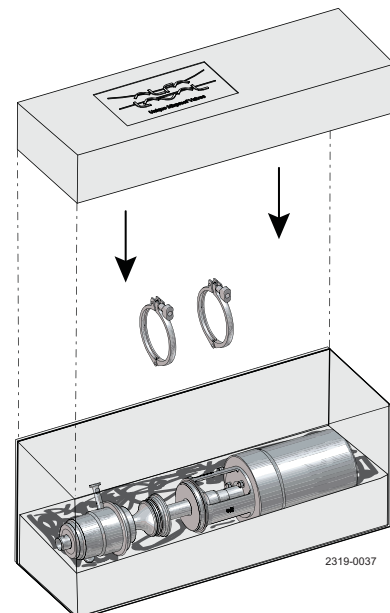

3.2 Recycling

• Unpacking

- Packing material consists of wood, plastics, cardboard boxes and in some cases metal straps
- Wood and cardboard boxes can be re-used, recycled or used for energy recovery
- Plastics should be recycled or burnt at a licensed waste incineration plant
- Metal straps should be sent for material recycling.

• Maintenance

- During maintenance, oil and wearing parts in the machine are replaced
- All metal parts should be sent for material recycling
- Worn out or defective electronic parts should be sent to a licensed handler for material recycling
- Oil and all non-metal wear parts must be disposed off in accordance with local regulations

• Scrapping

- At the end of use, the equipment must be recycled according to the relevant, local regulations. Besides the equipment itself, any hazardous residues from the process liquid must be considered and dealt with in a proper manner. When in doubt, or in the absence of local regulations, please contact your local Alfa Laval sales company

3.3 General installation

Step 1



- Always read the technical data thoroughly (see section 7 Technical data).
- Always release compressed air after use.
- Never touch the clip assembly or the actuator piston rod if the actuator is supplied with compressed air (see the warning label)



CAUTION!

- Fit the supplied warning label on the valve so that it is clearly visible.
- Alfa Laval cannot be held responsible for incorrect installation

NOTE!

- Mount valves vertically, or as close to vertical as possible having the leakage outlet turned downwards.

Step 2

Avoid stresses to the valve as this can result in deformation of the sealing area and malfunction of the valve (leakage or faulty indication).

Pay special attention to:

- Vibrations
- Thermal expansion of the tubes (especially at long tube lengths)
- Excessive welding
- Overloading of the pipelines

NOTE!

Please follow Alfa Laval installation guidelines (literature code ESE00040).

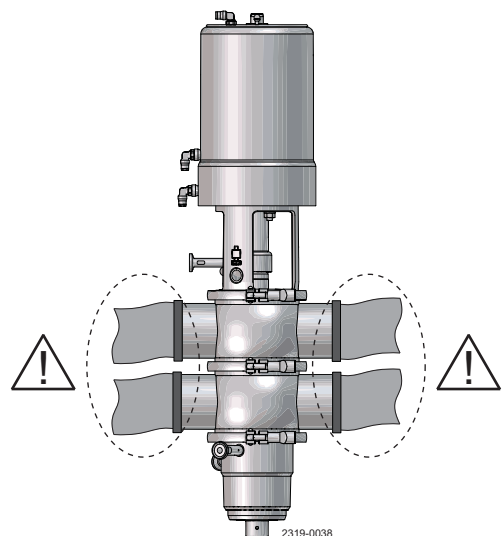

3 Installation

Study the instructions carefully and pay special attention to the warnings!
 The valve has ends for welding as standard but can also be supplied with fittings.

Step 3

Fittings

Ensure that the connections are tight.

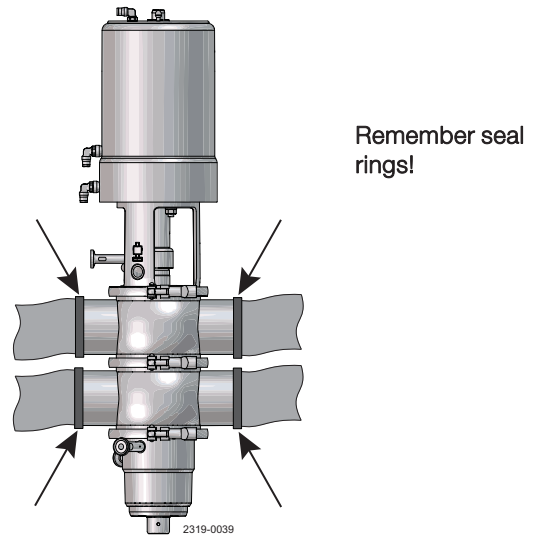

Step 4

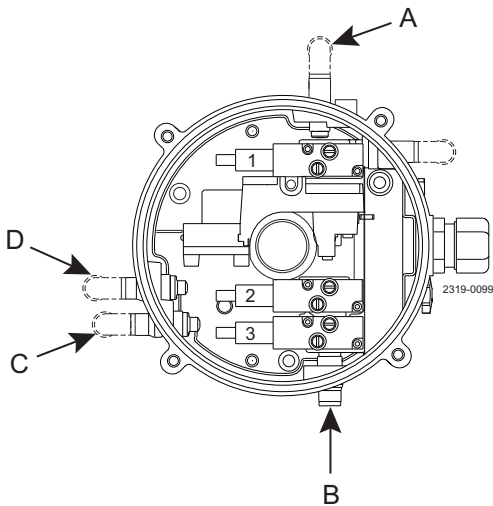

A = Air out 1A
 B = Air in
 C = Air out 3
 D = Air out 2

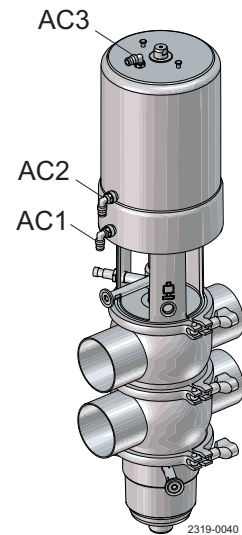

AC1 = Air connection 1 (red) upper seat push
 AC2 = Air connection 2 (blue) open/close
 AC3 = Air connection 3 (yellow) lower seat push

Valve Pneumatic Connections	
ThinkTop Fitting ID	Actuator Fitting ID
Out 1A	Air connection 2 (blue)
Out 2	Air connection 3 (yellow)
Out 3	Air connection 1 (red)

Air connection: R 1/8" (BSP).

Study the instructions carefully and pay special attention to the warnings!

The valve has ends for welding as standard.

Weld carefully/aim at stressless welding to avoid deformation on sealing areas.

Check the valve for smooth operation after welding.

3.4 Welding

Step 1



Never stick your fingers in the operating parts of the valve if the actuator is supplied with compressed air.

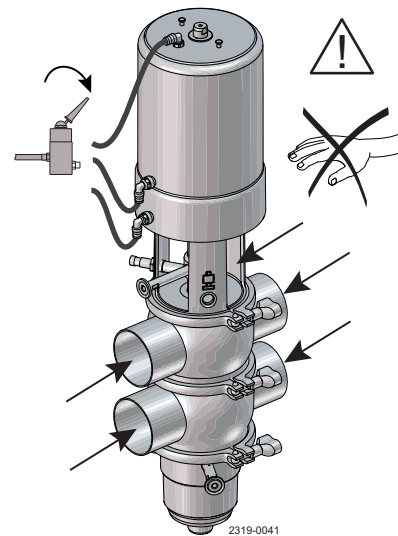

Step 2

Dismantle the valve in accordance with the description of dismantling the valve, see 6.2 Dismantling of valve

Step 3



Before welding the valve into the pipe line please note:

1. Maintain the minimum clearances "A" so that the actuator with the internal valve parts can be removed - please see later on in this section!

If there is a risk of foot damage, Alfa Laval recommends leaving a distance of 4.7" below the valve (look at the specific built-in conditions).

Size	1½"	2"	2½"	3"	4"	6"
A	7.9"	10.4"	11.8"	11.8"	17.2"	14.76"
B	31.9"	34.3"	40.2"	40.2"	49.2"	55.9"
C	2.4"	2.9"	3.4"	3.9"	4.7"	6.9"

Note!

If ThinkTop is mounted, add 7.1" to B measurement.

The measurement C can always be calculated by the formula $C = \frac{1}{2}ID_{upper} + \frac{1}{2}ID_{lower} + 1"$

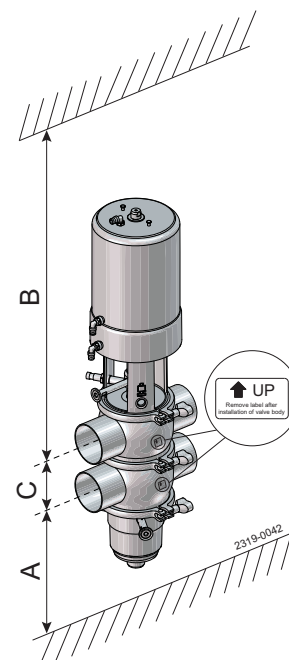

Step 4

Assemble the valve in accordance with section 6.5 Assembly of valve after welding.

Pay special attention to the warnings and clamp torque (see section 6.5 Assembly of valve).

3 Installation

Study the instructions carefully and pay special attention to the warnings!

The valve has ends for welding as standard.

Weld carefully/aim at stressless welding to avoid deformation on sealing areas.

Check the valve for smooth operation after welding.

Step 5

Pre-use check:

1. Supply compressed air to air connection 1, 2 and 3 one by one.
2. Operate the valve several times to ensure that it runs smoothly.

Pay special attention to the warnings!

- AC1 = Air connection 1 (red) upper seat push
 AC2 = Air connection 2 (blue) open/close
 AC3 = Air connection 3 (yellow) lower seat push

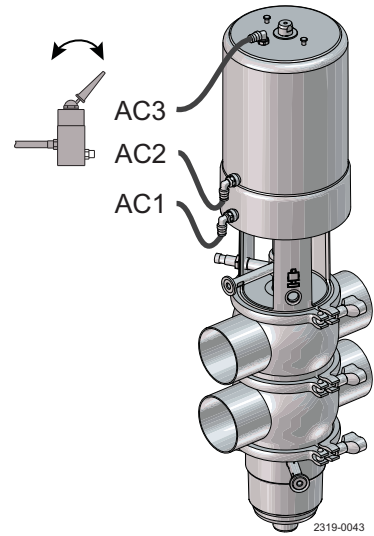

3.5 Pneumatic functions

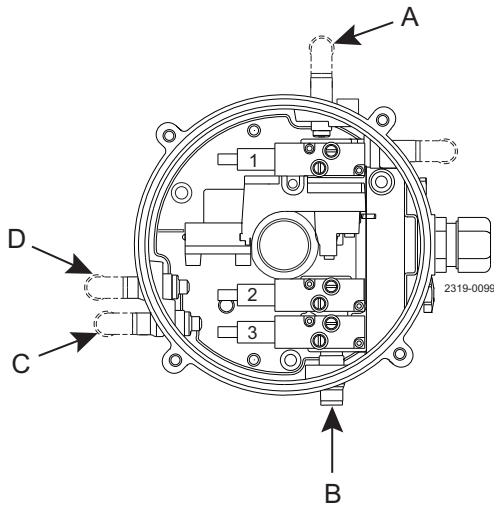

- A = Air out 1A
 B = Air in
 C = Air out 3
 D = Air out 2

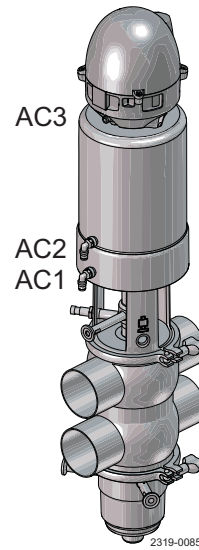

Valve pneumatic connections	
ThinkTop Fitting ID	Actuator Fitting ID
Out 1A	AC 2 (blue)
Out 2	AC 3 (yellow)
Out 3	AC 1 (red)

Study the instructions carefully and pay special attention to the warnings!

The valve has ends for welding as standard.

Weld carefully/aim at stressless welding to avoid deformation on sealing areas.

Check the valve for smooth operation after welding.

3.6 Valve position indication

ThinkTop Visual Indications

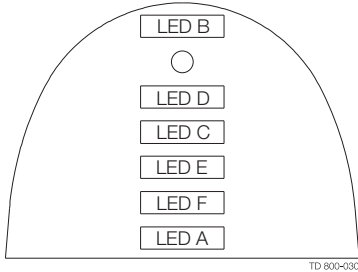

TD 800-030

LED Indications

LED B	"Open valve" (Yellow)
O	IR-Receiver
LED D	"Setup/Internal fault" (Red)
LED C	"Seat-lift 1/2" (Yellow)
LED E	"Solenoid valves" (Green)
LED F	"Maintenance" (Orange)
LED A	"Closed valve" (Yellow)

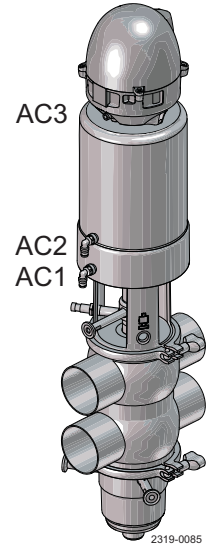

2319-0085

Note:

If the programmer wishes to detect a physical closed valve position in an "Open Valve" sensor position, then there is no longer any consistence between the sensor valve detection position and the visual indications of the ThinkTop.

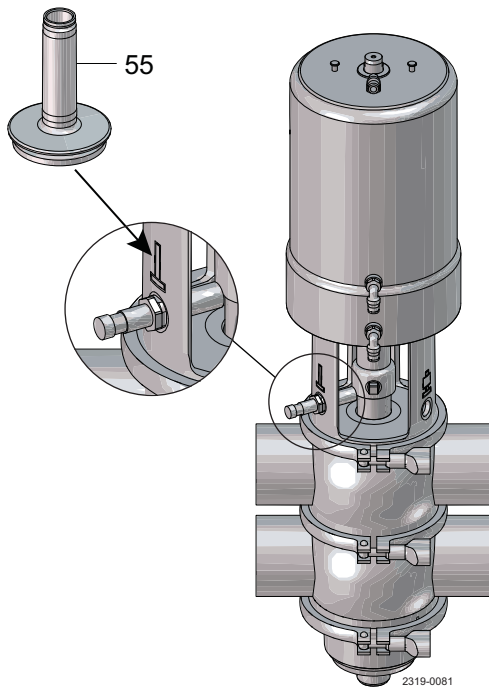

2319-0081

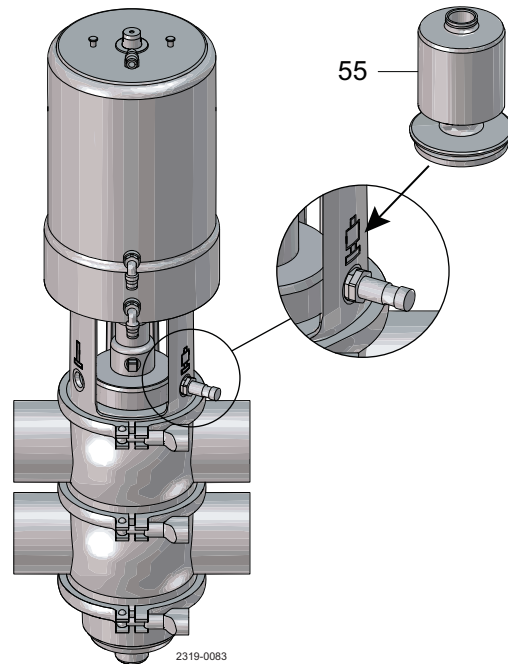

2319-0083

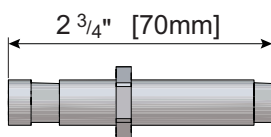

2319-0082

External sensor - unbalanced plug

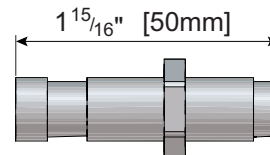

2319-0084

External sensor - balanced plug

3 Installation

Study the instructions carefully and pay special attention to the warnings!

The valve has ends for welding as standard.

Weld carefully/aim at stressless welding to avoid deformation on sealing areas.

Check the valve for smooth operation after welding.

3.7 Adjustment of indication

Test 1 - Upper valve seat, position detection

1. Valve at rest (closed) position
"C" LED (seat lift) on ThinkTop is illuminated.
2. Attach a manual air line to actuator air fitting AC1 using a 3-way air pilot switch.
3. Turn the air pilot switch to ON (open).
"C" LED (seat lift) on ThinkTop is not illuminated.
4. Turn the air pilot switch to OFF (closed).
"C" LED (seat lift) on ThinkTop is illuminated.
5. Test complete. Remove manual air line.

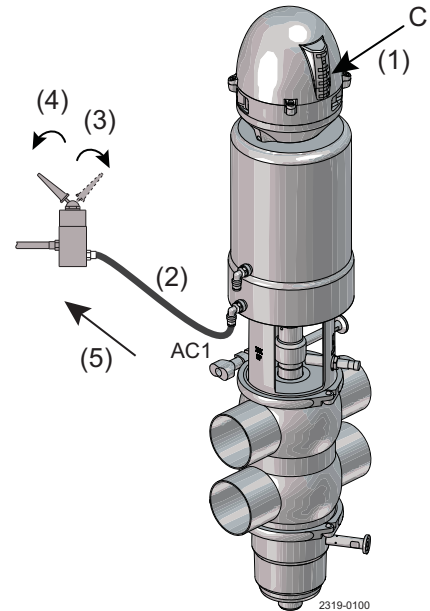

Test 2 - Lower valve seat, position detection

1. Valve at rest (closed) position
"A" LED (closed valve) on ThinkTop is illuminated.
2. Attach a manual air line to actuator air fitting AC3 using a 3-way air pilot switch.
3. Turn the air pilot switch to ON (open).
"A" LED (closed valve) on ThinkTop is not illuminated.
4. Turn the air pilot switch to OFF (closed).
"A" LED (closed valve) on ThinkTop is illuminated.
5. Test complete. Remove manual air line.

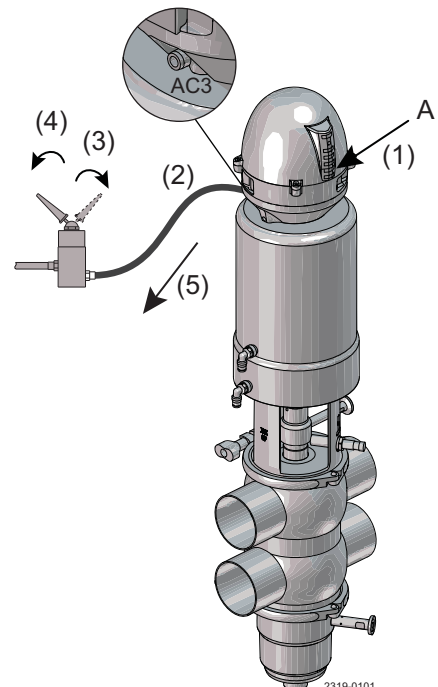

Study the instructions carefully and pay special attention to the warnings!

The valve has ends for welding as standard.

Weld carefully/aim at stressless welding to avoid deformation on sealing areas.

Check the valve for smooth operation after welding.

Adjustments

Upper valve seat external sensor (24VDC or 110VAC)

(position data existing on ThinkTop)

The following instructions should be made while the valve is hot from CIP cleaning. (worst case)

1. Valve is in rest position.
2. Loosen sensor lock nut(s).
3. Turn the sensor (83) clockwise to bottom of nylon plug (82), (or in some cases, until the sensor LED turns off).
4. Turn the sensor (83) counter clockwise until the sensor LED turns on, (or approximately one full turn from bottom of plug).
5. Lightly tighten sensor lock nut(s).
6. Attach a manual air line to actuator fitting AC1 using a 3-way air pilot switch.
7. Turn the air pilot switch to ON (open). Upper seat lift activated. Sensor LED turns off.
8. Turn the air pilot switch to OFF (closed). Upper seat lid deactivated. Sensor LED turns on.
9. Turn the air pilot switch ON and OFF several times to verify sensor LED actions as listed in steps 7 and 8 above.
10. Moderately tighten sensor lock nut.
11. Repeat step 9 when the valve is cold and readjust with valve hot if necessary.

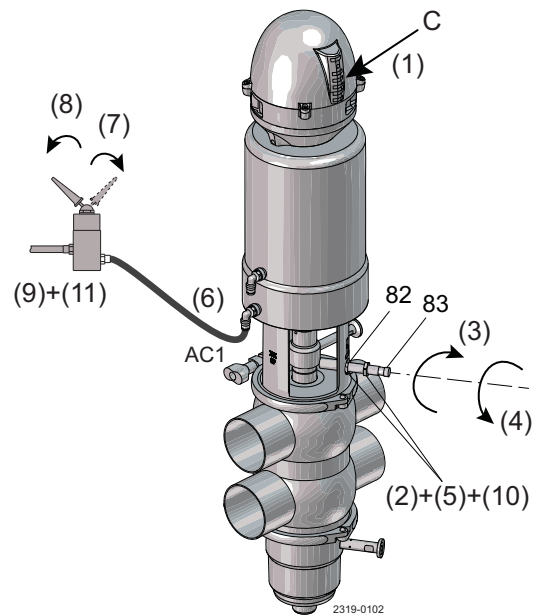

Adjustments

Upper valve seat ThinkTop (set position "New" on ThinkTop)

The following instructions can be completed while the valve is at room (ambient) temperature.

1. Enter new "Upper seat lift" position data to ThinkTop memory in step 5 of the programming sequence using the "I" and "II" keys.

Note! Data entry is done with the valve deactivated (closed).

2. Adjust lateral sensor per instructions for "UPPER VALVE SEAT EXTERNAL SENSOR" in this section. Refer to "Electrical connections/Instructions" in this manual for ThinkTop programming.

Adjustments

Lower valve seat ThinkTop

The following instructions can be completed while the valve is at room (ambient) temperature.

1. Delete the current "CLOSED VALVE" position data from the ThinkTop memory using the "I" and "II" keys.
2. Enter new "CLOSED VALVE" position.
3. Repeat "Test - 2, lower valve seat position detection" procedures to confirm adjustment.

Refer to "Electrical connection/instructions" in this manual for ThinkTop programming.

3 Installation

Study the instructions carefully and pay special attention to the warnings!

The valve has ends for welding as standard.

Weld carefully/aim at stressless welding to avoid deformation on sealing areas.

Check the valve for smooth operation after welding.

3.8 Regulatory Inspection

Test 3

Regulatory inspection, confirm control system seat lifting interlock during an operating, active CIP circuit

Description of components to be used for this test:

1. ThinkTop® (blue control module located on top of the air actuator)
2. Compressed air solenoids (when furnished inside ThinkTop®**) see page 33 for top view of solenoid layout inside ThinkTop®.
 - a. Solenoid-1, valve full open. (Note: not used for this test procedure)
 - b. Solenoid-2, lower seat push activation.
 - c. Solenoid-3, upper seat lift activation.

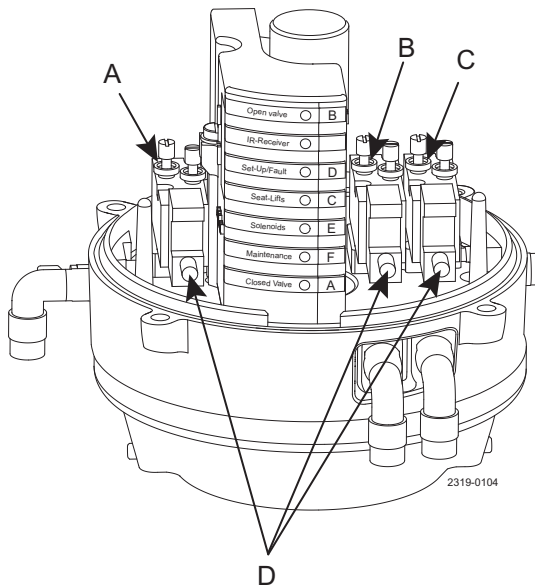

- A. Solenoid 1
- B. Solenoid 2
- C. Solenoid 3
- D. Manual air pilot buttons

Test procedure listed as follows:

1. Select a valve for interlock testing.
2. Decide if the cleaning solution will flow through the mixproof valve upper or lower body as part of the CIP cleaning circuit for the test.
3. Start the appropriate CIP circuit. (WARNING: be sure that there is no risk of mixing product with cleaning solution when conducting this test!!)
4. The CIP supply pump, or source of CIP solution pressure, should now be operating.
5. Remove the cover lid from the Think Top.

Move to step 6 or 7 below:

6. If cleaning solution is flowing through the valve upper body, push and hold the silver manual air pilot button on solenoid number 2 (lower seat push). If control system interlock is correct, the CIP supply pump, or source of CIP solution pressure, will be de-activated. Release manual air pilot button to end this test.
7. If cleaning solution is flowing through the valve lower body, push and hold the silver manual air pilot button on solenoid number 3 (upper seat lift). If the control system interlock is correct, the CIP supply pump, or source of CIP solution pressure, will be de-activated. Release manual air pilot button to end this test.
8. If the control system does NOT de-activate the cleaning solution pressure source as described in either 6 or 7 above, the control system should be shut down for evaluation, and correction, to the interlock functions written in the PLC logic.

** If solenoids are located in a remote enclosure (not inside Think Top), the above test procedures are to be conducted in exactly the same method. Selection of the proper solenoids for testing are to be determined using the assistance of plant operating personnel.

Study the instructions carefully and pay special attention to the warnings!

The valve has ends for welding as standard.

Weld carefully/aim at stressless welding to avoid deformation on sealing areas.

Check the valve for smooth operation after welding.

3.9 Electrical connection chart

Table 1. ThinkTop, 8-30 VDC (0 solenoid)

ThinkTop Term no.	Function	Remarks
9	+8-30 VDC	Power +
10	- Common	Power -
	Ground	-----
1	Closed valve	PLC input - valve closed
2	Open valve	PLC input - valve open
3	Seat lift - 1	PLC input - valve closed
5	Status	PLC input - optional
24	Seat Lift -1(upper) (signal)	External sensor (WHT)
26	Supply +	External sensor (BRN)
27	Supply -	External sensor (BLU)
	Not used -	External sensor (BLK)

Table 2. ThinkTop, 8-30 VDC (3 solenoids)

ThinkTop Term no.	Function	Remarks
6	Solenoid - 1	Output - valve open
7	Solenoid - 2	Output - lower seat lift push
8	Solenoid - 3	Output - upper seat lift
9	+8-30 VDC	Power +
10	- Common	Power - *(jump to 11)
11	Solenoid com.	Power - * (jump to 10)
	Ground	-----
1	Closed valve	PLC input - valve closed
2	Open valve	PLC input - valve open
3	Seat lift - 1	PLC input - valve closed
5	Status	PLC input - optional
24	Seat Lift -1(upper) (signal)	External sensor (WHT)
26	Supply +	External sensor (BRN)
27	Supply -	External sensor (BLU)
	Not used -	External sensor (BLK)

* = One power supply, positive activation of solenoids.

3 Installation

Study the instructions carefully and pay special attention to the warnings!

The valve has ends for welding as standard.

Weld carefully/aim at stressless welding to avoid deformation on sealing areas.

Check the valve for smooth operation after welding.

Table 3. ThinkTop, 110 VAC (0 solenoid)

ThinkTop Term no.	Function	Remarks
9	110 VAC	Power +
10	- Common	Power -
	Ground	-----
1	Closed valve	PLC input - valve closed
2	Open valve	PLC input - valve open
3	Seat lift - 1	PLC input - valve closed
5	Status	PLC input - optional
24	Seat Lift -1(upper) (signal)	External sensor (red w/BLK rings)
26	Supply +	External sensor (red w/WHT rings)

Table 4. ThinkTop, 110 VAC (3 solenoids)

ThinkTop Term no.	Function	Remarks
6	Solenoid - 1	Output - valve open
7	Solenoid - 2	Output - lower seat lift push
8	Solenoid - 3	Output - upper seat lift
9	110 VAC	Power +
10	- Common	Power - *(jump to 11)
11	Solenoid com.	Power - * (jump to 10)
	Ground	-----
1	Closed valve	PLC input - valve closed
2	Open valve	PLC input - valve open
3	Seat lift - 1	PLC input - valve closed
5	Status	PLC input - optional
24	Seat Lift -1(upper) (signal)	External sensor (red w/BLK rings)
26	Supply +	External sensor (red w/WHT rings)
27	Supply -	External sensor (BLU)
	Not used -	External sensor (BLK)

* = One power supply, positive activation of solenoids.

The valve is tested before delivery.
Study the instructions carefully and pay special attention to the warnings!
Pay attention to possible faults.
The items refer to the parts list and service kits section.

4.1 Operation

Step 1



- **Always** read the technical data thoroughly (see section 7 Technical data).
- **Always** release compressed air after use.
- **Never** touch the clip assembly or the actuator piston rod if the actuator is supplied with compressed air (see the warning label).
- **Never** pressurise air connections (AC1, AC3) simultaneously as both valve plugs can be lifted (can cause mixing).

CAUTION!

Alfa Laval cannot be held responsible for incorrect operation.

Step 2



Never touch the valve or the pipelines when processing hot liquids or when sterilising.

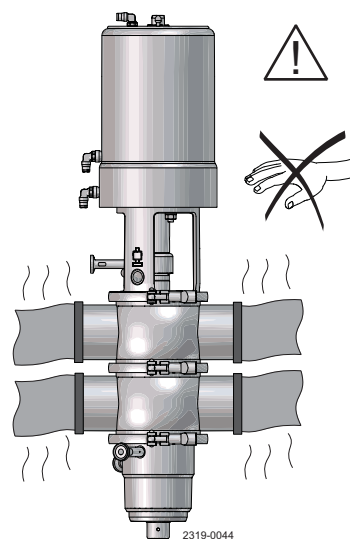

4 Operation

The valve is designed for cleaning in place (CIP).

Study the instructions carefully and pay special attention to the warnings!

NaOH = Caustic soda.

HNO₃ = Nitric acid.

4.2 Recommended cleaning

Step 1



Always handle lye and acid with great care.

Caustic danger!



Always use
rubber gloves!



Always use
protective goggles!

Step 2



Never touch the valve or the pipelines when sterilising.

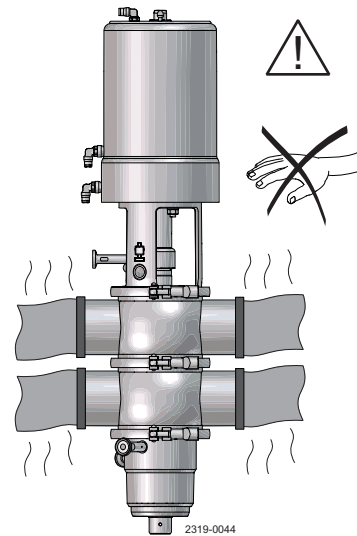

Step 3



- Never throttle the leakage outlet
- Never throttle the CIP outlet, if supplied.
(Risk of mixing due to overpressure).

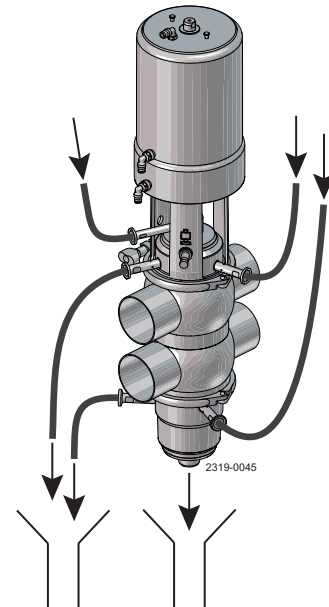

Step 4

1. Avoid excessive concentration of the cleaning agent
⇒ **Dose gradually!**
2. Adjust the cleaning flow to the process
Milk sterilisation/viscous liquids
⇒ **Increase the cleaning flow!**

The valve is designed for cleaning in place (CIP).

Study the instructions carefully and pay special attention to the warnings!

NaOH = Caustic soda.

HNO₃ = Nitric acid.

Step 5

Recommended cleaning - general

In order to be compliant with the Sanitary 3A Standard 85-03, the Unique Mixproof CP-3 valves shall be cleaned-in-place (CIP) with the following recommended procedures.

Each mixproof valve shall be properly operated, including seat lifting, during CIP cleaning to assure exposure to product contact surfaces.

Alfa Laval offers the option of cleaning the leakage chamber by utilizing the SpiralClean nozzle during the CIP Cleaning.

The SpiralClean nozzle is accessed through the external inlet located at the Intermediate piece.

The CIP through the SpiralClean nozzle can be controlled by an external valve. Minimum recommended CIP pressure 29 psi.

Alfa Laval offers the option of cleaning the OD of the upper and lower valve plug shaft(s) by utilizing the CIP sealing elements.

The CIP of the valve shaft(s) has an external inlet and outlet positioned on the sealing elements. Minimum recommended CIP pressure 29 psi.

The CIP through the SpiralClean nozzle can be controlled by an external valve(s).

Alfa Laval recommends that OD cleaning of the valve plug shafts is only performed during CIP of the valve. For example: If

only the upper portion of the valve body is cleaned while there is product present in the lower portion of the valve body.

OD cleaning should only be performed on the upper plug.

Step 6

Recommended cleaning - specific

The chart below provides reference to cleaning solution agents, temperature and exposure times necessary during circulation to achieve good cleaning results.

All data shown is required for each valve during cleaning. Use clean water, free from chlorides, for mixing with chemical cleaning agents.

CIP Event	Exposure Time	Temperature	Agent	Concentration
Warm pre-rinse	3 minutes continuous	100 – 110 °F	None	None
Hot alkaline wash	10 minutes continuous	160 °F	NaOH (Sodium hydroxide)	1%
Cold post wash	3 minutes continuous	Cold	None	None
Cold acidified rinse	3 minutes continuous	Cold	EHNO ₃ (Nitric acid)	0.006%

4 Operation

The valve is designed for cleaning in place (CIP).

Study the instructions carefully and pay special attention to the warnings!

NaOH = Caustic soda.

HNO₃ = Nitric acid.

Step 7

Valve pneumatic operation during in-place cleaning

Each valve seat shall be lifted during the length of the cleaning cycle.

Seat lift durations shall not exceed 10 seconds.

These pneumatic functions include:

1. Upper valve seat lift (cleaning of upper valve body)
2. Lower valve seat push (cleaning of lower valve body)

The following chart presents an overview of these functions together with the recommended time durations.

CIP event @ length	Valve function	Valve solenoid no.	Solenoid mode	PLC timer duration	Total valve function during CIP event length
Warm pre-rinse @ 3 minutes	Upper seat lift	3	Energized	*0.5 sec	3
	Lower seat lift	2	Energized	*0.5 sec	3
	SpiralClean vent	-	-	*0.5 sec	3
	OD cleaning	-	-	*5 sec	2
Hot alkaline wash @ 10 minutes	Upper seat lift	3	Energized	*0.5 sec	3
	Lower seat lift	2	Energized	*0.5 sec	3
	SpiralClean vent	-	-	*0.5 sec	3
	OD cleaning	-	-	*5 sec	2
Cold post wash @ 3 minutes	Upper seat lift	3	Energized	*0.5 sec	3
	Lower seat lift	2	Energized	*0.5 sec	3
	SpiralClean vent	-	-	*0.5 sec	3
	OD cleaning	-	-	*5 sec	2
Cold acidified rinse @ 3 minutes	Upper seat lift	3	Energized	*0.5 sec	3
	Lower seat lift	2	Energized	*0.5 sec	3
	SpiralClean vent	-	-	*0.5 sec	3
	OD cleaning	-	-	*5 sec	2

*Time stated is the actual opening time for the valve. Programmed duration is depended on the access to compressed air and response time from PLC.

Variations caused by compressed air are typically:

- Long compressed air supply hoses.
- Small ID on air supply hoses.
- Limited availability of compressed air.

Step 8

Consumption cleaning fluids

The table below approximates the flow of cleaning solution through the valve vent tube during seat lift functions, SpiralClean of vent and CIP of OD valve plug shafts at a CIP pressure of 30 psi.

Valve size	Seat lift seat push	Cv (gpm/psi)	Gallons per sec. (30psi)	Duration	Activations during each CIP event
1½" – 2"	Seat lift	2.9	0.265	0.5 sec	3
	Seat push	2.2	0.201		
2½" – 3"	Seat lift	3.6	0.329	0.5 sec	3
	Seat push	4.3	0.393		
4"	Seat lift	5.3	0.484	0.5 sec	3
	Seat push	4.9	0.447		
6"	Seat lift	6.0	0.548	0.5 sec	3
	Seat push	5.3	0.484		
SpiralClean 1½" to 6"	-	0.14	0.008	0.5 sec	3
CIP OD valve plug 1½" - 2"	-	0.29	0.026	5 sec	2
CIP OD valve plug 2½" - 6"	-	0.34	0.031	5 sec	2

The following formula is used to estimate CIP flow during seat lifts:

$$Q = C_v \cdot \sqrt{\Delta p}$$

Where Q is Flow in USGPM.

C_v is taken from the table above.

Δp is the CIP pressure in PSI.

The valve is designed for cleaning in place (CIP).

Study the instructions carefully and pay special attention to the warnings!

NaOH = Caustic soda.

HNO₃ = Nitric acid.

Step 9

Guide rings cleaning

When the valves are removed for replacement of wetted parts and / or sealing elastomers, it is important to remove, and hand clean, the PTFE guide rings (positions 45, 54, 80 and 98) and their seating groves before placing the valves back into service. See section 6.5 Assembly of valve

Step 10

Always rinse well with clean water after cleaning.

NOTE!

The cleaning agents must be stored/disposed of in accordance with current regulations/directives.

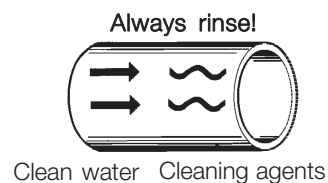

4 Operation

The valve is designed for cleaning in place (CIP).

Study the instructions carefully and pay special attention to the warnings!

NaOH = Caustic soda.

HNO₃ = Nitric acid.

Step 11

Seat-cleaning cycles:

Pay special attention to the warnings!

1. Closed valve

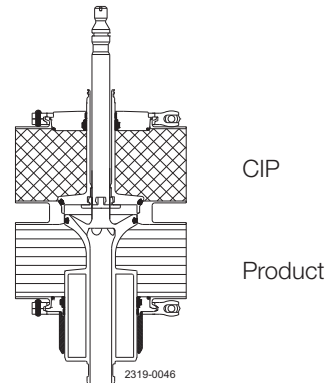

2. Cleaning through lower line

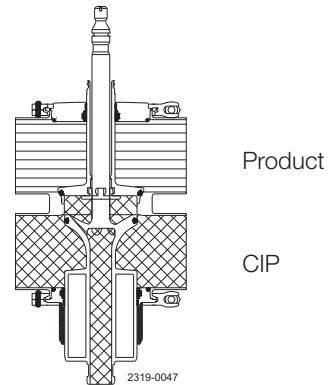

3. Open valve

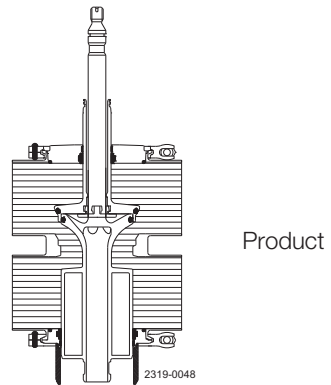

4. Cleaning through upper line

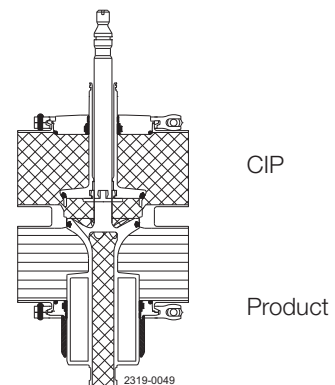

Study the maintenance instructions carefully before replacing worn parts. - See section 6.1 General maintenance

4.3 Troubleshooting and repair

Problem	Cause/result	Repair
Leakage between sealing element (79 or 96/97) and lower plug (75)	Worn/product affected o-rings/ lip seal (76/77/78/95)	<ul style="list-style-type: none"> - Replace the o-rings/lip seal - Change rubber grade - Lubricate correctly
Leakage at the leakage outlet	<ul style="list-style-type: none"> - Particles between valve seats and plug seals (56/74) - Worn/product affected plug seal rings (56/74) - Plug not assembled correctly 	<ul style="list-style-type: none"> - Remove the particles - Check the plug seals - Replace the plug seals - Change rubber grade - Assemble plug, see section 6.3 Lower plug, replacement of radial seal and section 6.4 Upper plug, replacement of axial seal
Leakage at sealing element (48)/upper plug (55)	Worn/product affected o-rings/lip seal (38/39/46/49)	<ul style="list-style-type: none"> - Replace the o-rings/lip seal - Change rubber grade - Clean and if necessary replace guide ring (45)
Leakage at clamp (64)	<ul style="list-style-type: none"> - Too old/product affected o-rings (76 and 47) (and 52 if clamped valve body) - Loose clamp (64) 	<ul style="list-style-type: none"> - Replace the o-rings - Change rubber grade - Tighten the clamp
CIP leakage	Worn o-rings (40/67/71/144/145)	Replace the o-rings
Leakage at spindle clamp (43)	Damaged o-ring (39) Worn/product affected lip seal (57) or spray nozzle (58)	<ul style="list-style-type: none"> - Replace the o-ring - Replace the plug seals - Change rubber grade
Lower plug not returning to closed position	<ul style="list-style-type: none"> - Wrong rubber grade - Wrongly fitted gasket - Mounted incorrectly (see section 6.3 Lower plug, replacement of radial seal) 	<ul style="list-style-type: none"> - Change rubber grade - Fit new gasket correctly - Correct installation
Plug returns with uneven movements (slip/stick effect)	<ul style="list-style-type: none"> - Wrong rubber grade - Wrongly fitted gasket - Mounted incorrectly (see section 6.3 Lower plug, replacement of radial seal) 	<ul style="list-style-type: none"> - Change rubber grade - Fit new gasket correctly - Correct installation

5 Automation

Study the instructions carefully and pay special attention to the warnings!

5.1 Specifications

“No Touch” sensor system

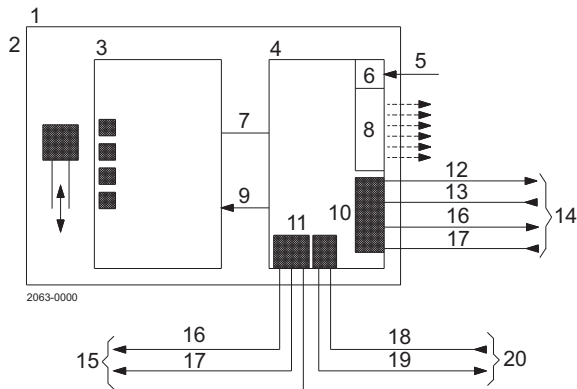

- | | |
|------------------------|--------------------------|
| 1. Sensor unit | 11. Terminals |
| 2. PLC, feedback | 12. Feedback signals |
| 3. Sensor board | 13. Solenoid signals |
| 4. PLC interface board | 14. PLC Cable |
| 5. IR Remote control | 15. Internal connections |
| 6. IR Rx | 16. Solenoid signals |
| 7. Serial link | 17. Solenoid common |
| 8. LEDs | 18. (PNP) |
| 9. +5 V | 19. Supply sensors |
| 10. Terminals | 20. External connections |

Type: Alfa Laval “No Touch” System. For wire connections: See 3.9 Electrical connection chart“.

Features

- Tolerance programmes.
- Self adjustment programme (SRC/ARC valves only).
- Built-in maintenance monitor.
- Setup by internal push buttons or remote control (IR Keypad).
- Setup and local fault supervision.
- Setup saved at power shutdown.
- Visual LED Indicator lights.

Sensor System

Unique “No Touch” sensor system without any mechanical sensor adjustments.

A magnet (indication pin) is mounted on the valve stem and the magnetic field (axial) is detected by sensor chips inside the sensor board. The measuring angle from each chip is used to locate the current position of the valve stem with an accuracy of ± 0.004 ". Note that the distance to the indication pin can be $3/16" \pm 1/8"$.

Feedback signals

The sensor system can be used for 4 feedback signals + 1 status signal = 5 digital PNP/NPN feedback signals. Selection of PNP or NPN is done by a jumper. Two of the feedback signals can be used for external sensors if necessary.

The status signal is used for detection of the following three conditions:

- A set-up is in progress.
- Internal error.
- Maintenance is required (based on time and/or the self adjustment programme).

Tolerance programme

Individual programme according to valve types.

- | | |
|---------|---|
| Type 0: | Bypass valve type / SMP-EC / keep present valve type. |
| Type 1: | SRC/ARC and Series 700 valves, only when self adjustment is enabled - Not recommended. |
| Type 2: | LKB (LKLA-T). |
| Type 3: | Unique Mixproof, SMP-SC Spillage-Free, and SRC-PV/AMP. |
| Type 4: | SMP-SC, SMP-TO, SMP-BC, SMP-BCA, SBV, SRC, ARC, Unique SSV, Unique SSV Aseptic, Unique-TO, Series 700 valves, Unique Mixproof PMO, Unique Mixproof Curd, Unique Mixproof LP, Unique Mixproof HT, Unique Mixproof VT, Unique Mixproof CP-3 |
| Type 5: | All Parameters Set To Default (also valid for MH valve and SMP-EC (seat-lift indication not possible for SMP-EC)). |

Preset and reset values: Tolerance programme No./Type 5 ($\pm 3/16$ ") and all functions are disabled.

Note! Important to select the right tolerance programme in order to ensure optimum controlled closeness of valves. Tolerance pack 4 are the only valid for Mixproof valves in dairy applications.

Study the instructions carefully and pay special attention to the warnings!

Built-in Maintenance Monitor

The unit can be preset to indicate when the time for maintenance of the valve has been reached. A status signal and flashing maintenance LED can be programmed to return after 3, 6, 9 or 12 months or more.

Technical specifications

Sensor system

Sensor accuracy: ± 0.004 "
 Distance to indication pin: $3/16$ " $\pm 1/8$ "
 Stroke length: 0.004 " - $3 1/8$ "

Electrical connection:

Direct main cable gland entry (hard wired) PG11 ($\varnothing 3/16$ " - $\varnothing 3/8$ ").
 Direct external/sensor cable gland entry PG7 ($\varnothing 1/8$ " - $\varnothing 1/4$ ") option, external sensor.

Terminals

The terminal row of the sensor unit is equipped with screw terminals for both internal as well as external cables and wires. The terminals are suitable for wires up to 0.03" (AWG 19).

Power Supply, must meet the requirements of EN 61131-2.

The ThinkTop® is designed to be a part of the PLC's Input/Output (I/O) system. It should be supplied from the same protected power supply as the other I/O devices. The I/O power supply should not be used for other kinds of loads.

The unit is reverse polarity and short circuit protected.

Supply voltage:	8 - 30 or 100 - 126.5 VAC.
Supply voltage nominal:	24 or 110 VAC (+15%, -10%) - pr. EN 61131-2.
Supply voltage absolute max.:	30 or 126.5 VAC.
Supply voltage absolute min.:	8 or 100 VAC.
Power consumption*):	Max. 1.5 VA (8-30 VAC) or max. 2.0 VA (110 VAC) (for sensor unit alone) (excluding current to the solenoids, external sensor and the PLC input current).

*) The initial current during power-on is higher. Typical values are 440 mA RMS during 10 ms (the first half cycle) followed by 270 ms at 2 x normal steady state current).

The fulfilling of the UL requirements in UL508 requires that the unit is supplied by an isolating source complying with the requirements for class 2 power units (UL1310) or class 2 and 3 transformers (UL1585).

Feedback signals

Output signals from the sensor unit to the connected PLC.

Nominal voltage:	Must match the selected type of ThinkTop®.
Load current:	Typically 50 mA, max. 100 mA.
Voltage drop:	Typically 3 V at 50 mA.

5 Automation

Study the instructions carefully and pay special attention to the warnings!

External sensors

The external sensors are used for seat-lift supervision when seat-lift can not be internally detected.

The sensors get their supply voltage from the terminal row. The output signals from the sensors are connected to two inputs on the terminal row on the internal sensor unit.

If the actual setup is set for internal seat-lift, the corresponding external signal is not used, otherwise the external signal logically controls the corresponding feedback to the PLC (Programmable Logic Controller).

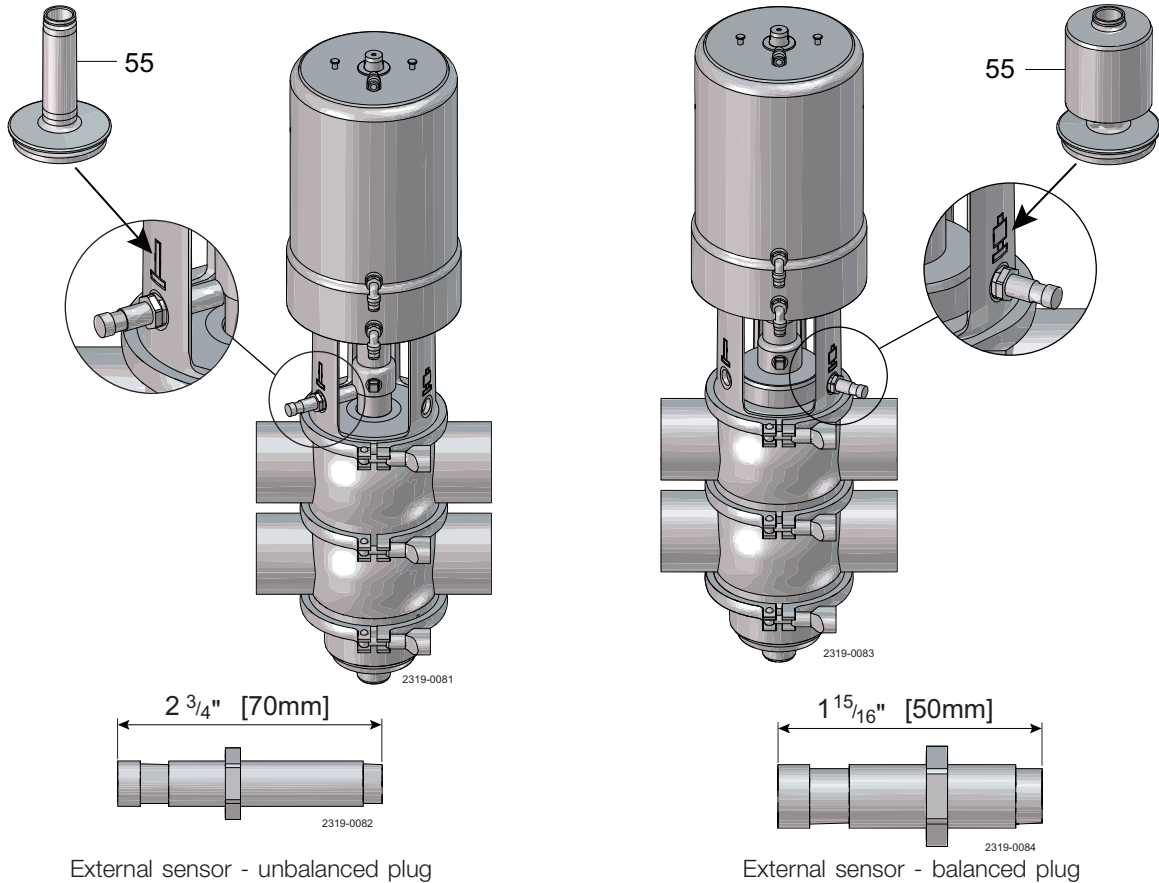

Note!

If using external sensor, the sensor must be active/activated when performing a setup routine of the control head.

Supply voltage:	Must match the selected type of ThinkTop®.
Supply current:	Max. 15 mA per sensor.
Type of sensor:	2 wire VAC (EN60947-5-2).
Sensor cable length:	Max. 118 1/8"

Study the instructions carefully and pay special attention to the warnings!

Polarity

NO or NC function is selected with a jumper in term. 12 and 13.

Jumper present = NO. If changing to NC remove the jumper and make a power recycle. A power recycle is always required when changing this function.

ThinkTop Visual Indications

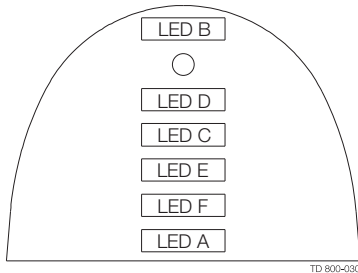

LED Indications

LED B	“Open valve” (Yellow)
O	IR-Receiver
LED D	“Setup/Internal fault” (Red)
LED C	“Seat-lift 1/2” (Yellow)
LED E	“Solenoid valves” (Green)
LED F	“Maintenance” (Orange)
LED A	“Closed valve” (Yellow)

Note: If the programmer wishes to detect a physical closed valve position in an “Open Valve” sensor position, then there is no longer any consistence between the sensor valve detection position and the visual indications of the ThinkTop.

Technical specifications solenoid valves

Solenoid signals Three output signals (with one common, terminal 11) from the terminal row are used for activation of the solenoids.

Depending on the PLC used, the common could be either positive (connected with terminal 9) or negative for DC voltage. The signals are galvanically isolated from the sensor circuits.

5 Automation

Study the instructions carefully and pay special attention to the warnings!

Internal connections Terminals for connection of the solenoids mounted internally in the control head. The number of solenoids actually mounted in the control head could be 0 - 3. The signals are taken directly from the terminal row.

Technical specifications	
Up to 3 solenoid valves in each unit.	
Type	3/2 or 5/2 valve (only possible with one 5/2 valve).
Air supply	43.5 - 130.5 psi
Filtered air, max. particles or dirt	5 μ 5-5 mg/m ³ .
Max. flow	47.6 gal/min
Max. oil content	1.4 10 ⁻⁷ oz/gal
Max. water content	1.2 10 ⁻⁴ oz/gal -20 °C compressed air.
Throughput	ø0.098"
Air restriction (throttle function) air inlet/outlet.	Yes.
Manual hold override.	Yes.
External air tube connection	1/4"
Nominal voltage	24 or 110 VAC
Nominal power	1.0 W.
Silencer/filter *)	Connection possible via 1/4". (Filter recommended in tropical regions).
Materials	
Plastic parts	Nylon PA12.
Steel parts	Stainless steel AISI 304 and 316
Seals	Nitrile (NBR), EPDM rubber for SMP-EC actuator stem.
Gore vent. membrane	PBT plastic.

*) **Notel** Filter recommended in tropical regions.

Micro environment demand specifications

Temperature		
Working:	-4°F to +185°F	IEC 68-2-1/2
Storage:	-40°F to +185°F	IEC 68-2-1/2
Temperature change:	-13°F to +158°F	IEC 68-2-14
Vibration		
	10-55 Hz, 0.7 mm	IEC 68-2-6
	55-500 Hz, 10g	
	3 x 30 min, 1 octave/min	
Drop test		
		IEC 68-2-32
Humidity		
Constant humidity:	-104°F, 21 days, 93% R.H.	IEC 68-2-3
Cyclic humidity:	+77°F / +133°F	
	12 cycles	IEC 68-2-30
(working)	93% R.H.	
Protection class		
	IP66 and IP67	IEC 529
Input treshold		
Voltage/current:	Type 1 input requirements	EN 61131-2
Solenoid signals		
isolation voltage	(1000 + 2 x 117) VAC ms/1 min	EN61131-2
EMC Directive		
	2004/108/EF	EN 61000-6-3, EN 61000-6-2
UL/CSA Approval		
	8-30 VAC	UL 508-E203255
	110 VAC	UL 508-E203664

Study the instructions carefully and pay special attention to the warnings!

Air connections

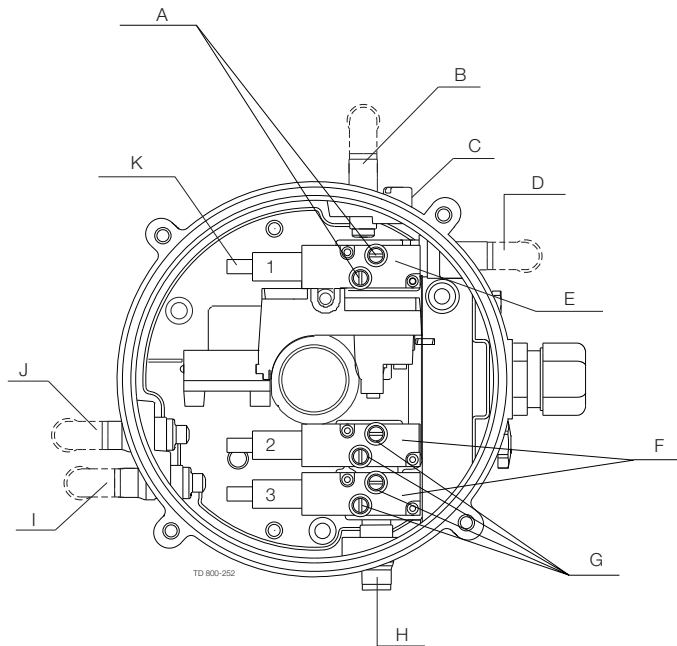

- A. Air restriction (throttle function) air inlet/outlet
- B. Air out 1A
- C. Air exhaust
- D. Air out 1B (5/2 port solenoid valve only)
- E. Solenoid 3/2 or 5/2
- F. 3/2 Solenoid valves only
- G. Air restriction (throttle function) air inlet/outlet
- H. Air in
- I. Air out 3
- J. Air out 2
- K. Manual hold override

5 Automation

Study the instructions carefully and pay special attention to the warnings!

5.2 Installation

Step 1



Always read the technical data thoroughly.



Always have the ThinkTop® electrically connected by authorised personnel.

Step 2

1. Fit the air fittings on actuator if not mounted.
2. Fit the activator stem (magnet) and tighten **carefully** with a spanner.

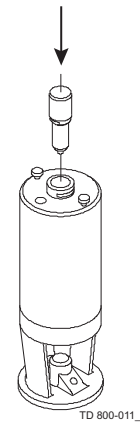

Step 3

1. Place the ThinkTop on top of the actuator.
2. Make sure X-ring is mounted.

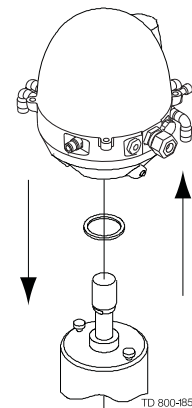

Step 4

1. Ensure that the unit is correctly mounted by **pressing** down on top of the ThinkTop.
2. Tighten the two Allen screws **carefully** (1.50 Nm).
3. Turn the actuator to have LEDs in a front view.

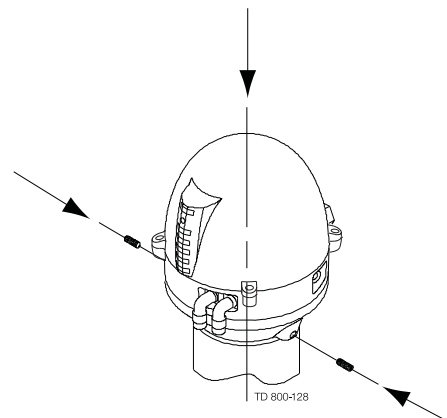

Study the instructions carefully and pay special attention to the warnings!

Step 5

Fit the $\varnothing 6$ mm (1/4") air tubes to ThinkTop.
(see drawing "Air connections" section 5.1 Specifications).

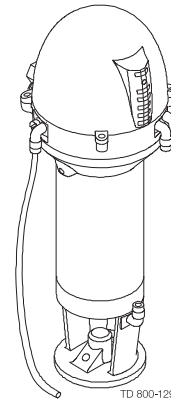

Step 6

Fit the air tubes to the actuator
(see drawing "Air connections" section 5.1 Specifications).

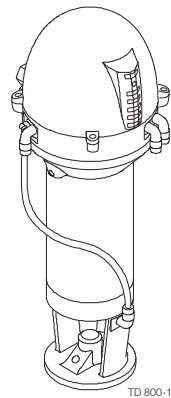

Step 7

Uptighten the four screws and pull off cover of ThinkTop.

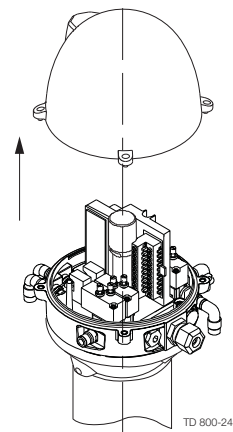

Step 8

1. Install cable (if not present) through the cable gland.
2. Connect the ThinkTop electrically
(see section 3.9 Electrical connection chart).

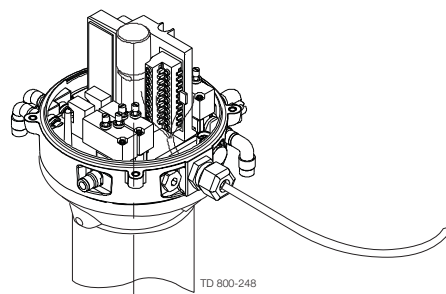

5 Automation

Study the instructions carefully and pay special attention to the warnings!

Step 9

Make sure the cable gland is completely tightened.

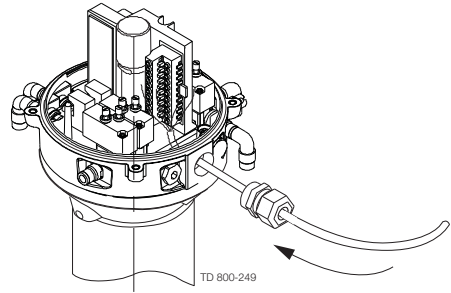

Step 10

Set up the ThinkTop (see section 5.3 Setup diagram).

Study the instructions carefully and pay special attention to the warnings!

5.3 Setup diagram

General

Flashing LED means no value set. Steady LED means value set as shown.

Default: Step 2, factory-set tolerance band +/- 3/16"
Step 3-8, disabled

D LED: Active during set-up: Flashing in step 1
Steady in all other steps

Or during operations, error condition: Steady showing hardware fault, indication pin out of range
Flashing showing software fault

Timeout: A 60 sec. timeout is started as soon as any button(s) are released
On timeout the setup is exited with no changes saved

Symbols

Simple representation of LED indication:

Yellow	B	<input type="checkbox"/>	
IR-Receiver		<input type="radio"/>	
Red	D	<input checked="" type="checkbox"/>	Steady LED
Yellow	C	<input type="checkbox"/>	
Green	E	<input type="checkbox"/>	
Orange	F	<input type="checkbox"/>	
Yellow	A	<input type="checkbox"/>	Flashing LED



General commands in each step (except step 1):

0	Next step / skip step	(In step 3-6 the program automatically moves to the next step when a position is stored)
5	Clear / disable step	(In step 2 this resets the unit and sets the step 2-8 to default) (The command is accepted when all unit LED's flash briefly)

**It is recommended to reset the unit before performing a setup.
Always check for correct signals after the setup.**

5 Automation

Study the instructions carefully and pay special attention to the warnings!

Step 0 Enter Setup

Next step: B D C E F A

1 Save and Exit
2 Exit no change accepted

Step 2 – Setup valve type

Next step: B D C E F A

<input type="checkbox"/> SRC/ARC Series 700	<input type="checkbox"/> LKB (LKLA-T)	<input type="checkbox"/> Unique Mixproof SMP-SC SF	<input type="checkbox"/> SMP-SC SMP-BC	Unique 7000
<input checked="" type="checkbox"/> (Only used when self adjustment feature is required)	<input type="checkbox"/>	<input type="checkbox"/> SRC-PV AMP	<input type="checkbox"/> SMP-TO SMP-BCA	Unique Mixproof PMO/Curd
	<input type="checkbox"/>	<input type="checkbox"/>	<input type="checkbox"/> SBV	Unique Mixproof CP-3/LP
			<input type="checkbox"/> Unique SSV	Unique Mixproof HT/VT
			<input type="checkbox"/> SRC/ARC Series 700	Unique Mixproof 3A

1 2 3 4 5 Reset unit

Step 3 – Set closed position

Next step: B D C E F A

Position stored. Cleat position 5

Activate the valve to the close position (De-energized)

1 auto

Step 4 – Set open position

Next step: B D C E F A

Position stored. Clear position 5

Activate the valve to the open position (Energized)

1 auto

Step 5 – Set upper seat lift.

Next step: B D C E F A

Position stored. Clear position 5

Activate the valve to upper seat lift. When using an external sensor the sensor must be active when "1" is pushed

1 auto

Step 6 – Set lower seat lift.

Next step: B D C E F A

Position stored. Clear position 5

Activate the valve to lower seat lift. When using an external sensor the sensor must be active when "1" is pushed

1 auto

Step 7 – Set self adjust (Recommended: Disabled)

Next step: B D C E F A

<input type="checkbox"/> Default Disabled	<input checked="" type="checkbox"/> Associated with closed/open position	<input type="checkbox"/> Associated with closed position	<input checked="" type="checkbox"/> Associated with open position	Disable function 5
	<input type="checkbox"/>	<input type="checkbox"/>	<input type="checkbox"/>	

1 2 3 5

Step 8 – Setup maintenance

Next step: B D C E F A



<input type="checkbox"/> Default Disabled	<input type="checkbox"/> 90 days	<input type="checkbox"/> 180 days	<input type="checkbox"/> 270 days	<input type="checkbox"/> 360 days	Disable function 5
	<input checked="" type="checkbox"/>	<input type="checkbox"/>	<input type="checkbox"/>	<input type="checkbox"/>	

1 2 3 4 5



Study the instructions carefully and pay special attention to the warnings!

Below is stated the meaning of the LEDs' indications for fault finding in connection with the operation of the ThinkTop.

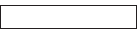
7.1.1 status LED (Red)

	Red flashing:	Unit in set-up mode or internal software fault. If internal software fault, re-programme unit.
	Red steady:	Unit in set-up mode or internal hardware fault. If internal hardware fault, check if magnet is in range and check correct wiring.
	Red steady:	No. communication between ThinkTop and the DeviceNet master, i.e. the bus is offline. If the Red LED is with random intervals and duration, it suggests that the bus is unstable, and the DeviceNet network should then be investigated. There are numerous issues that could lead to marginal operation of a network, bus load, voltage limits, impedance, termination, etc.

7.1.2 Maintenance time out

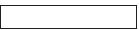
	1. Orange flashing:	Time for maintenance has run out. The unit has been self-adjusted into a maintenance alert condition. Valve maintenance is strongly recommended. After maintenance: Disabling of maintenance/self-adjustment function is required before setting new position, however, it is strongly recommended to make a complete new set-up after valve maintenance.
		
	2. Orange steady, yellow flashing (A and/or B):	The unit has been self-adjusted into a maintenance alarm condition and the feedback is lost (a minimum of seal left). Valve maintenance is required. After maintenance: Disabling of the self-adjustment function is required before setting new position, however, it is strongly recommended to make a complete new set-up after valve maintenance.

NOTE!

The maintenance indicator lighting up, and an open or closed light flashing..... =

Note the following:

- Self-adjustment programme is only valid for SRC/ARC valves, do not use the programme for other valve types.
- Use tolerance/valve type 1.
- In conjunction with valve type change-over; 21, 22, 31 and 32, the open position must be defined as the upper sensor position (when the indication pin is in the highest position).
- A loose top, indication pin or sensor system can also generate the alert/alarm condition.
- Removing a ThinkTop with self-adjust activated, will immediately generate an alarm condition! If the ThinkTop has to be removed, not because of a valve maintenance issue, but for some other reasons, and you want to store the already adjusted data - disable the self-adjust function before removing the ThinkTop and enable it again once the ThinkTop is back on the actuator.
- After valve maintenance a disabling of the self-adjustment function is required before setting a new position, however, it is strongly recommended to make a complete new set-up (disable all functions in step 2 valve type - and make a complete new set-up).

5 Automation

Study the instructions carefully and pay special attention to the warnings!

7.1.3 Solenoid green LED always on



Condition: When using a ThinkTop 110VAC, the Green LED is always on, but the solenoids seems to operate properly.

Possible cause: The off state voltage of the solenoid input is not sufficiently low.

Corrective action: Make sure that the off state voltage is below 7V.

7.2 LED indication during normal operation



Yellow steady: Position A (closed valve).

Yellow steady: Position B (open valve).



Yellow steady: Position C (Seat lift 1-2 or external sensors).

Study the instructions carefully and pay special attention to the warnings!

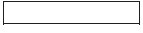
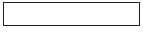

 Green steady: Solenoid valves energized.

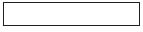

Note! During set-up LED lights have different functions.

5 Automation

Study the instructions carefully.

Handle scrap correctly.

Always keep spare X-rings in stock.

For spare parts please refer to spare part catalogue.

5.4 Maintenance

Step 1

1. Untighten the two Allen screws and remove the ThinkTop from the actuator.
2. Pull out X-ring (19) and replace it.

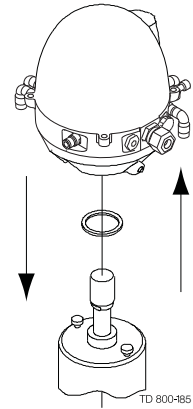

Step 2

1. Untighten the four screws.
2. Pull off cover of ThinkTop.
3. Remove X-ring (9) (grey).

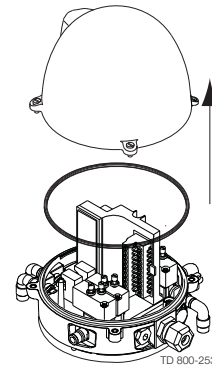

Step 3

1. Untighten screws.
2. Remove solenoid valves (up to three) and replace them with new ones.

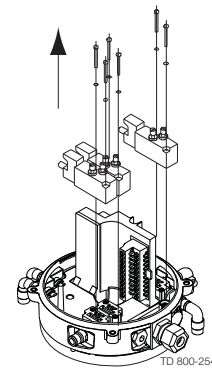

Step 4

1. To dismantle the adapter (the lower part of the ThinkTop) from base (the middle part), unscrew the three screws.
2. Turn the lower part a little clockwise and pull.
3. Replace adapter if necessary.
4. Remove the black X-ring.

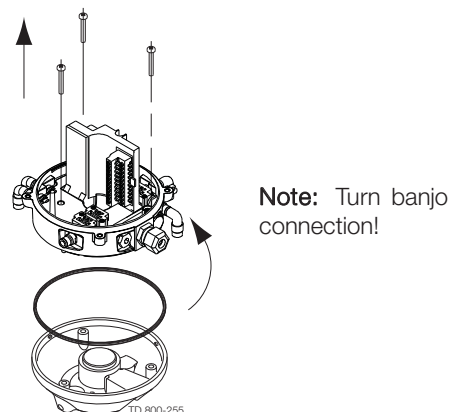

Study the instructions carefully.

Handle scrap correctly.

Always keep spare X-rings in stock.

For spare parts please refer to spare part catalogue.

Step 5

To remove the sensor unit untighten screw and pull out the sensor unit.

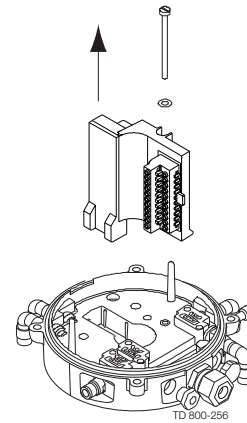

6 Maintenance

The valve is designed so that internal leakages do not result in the products becoming mixed.

Internal leakage in the valve is externally visible.

Study the instructions carefully.

Always keep spare rubber seals and guide rings in stock. Check the valve for smooth operation after service.

6.1 General maintenance

Recommended spare parts: service kits (see 8 Parts list and service kits)

Order service kits from the service kits section, see 8 Parts list and service kits

Ordering spare parts: contact the sales department.

	Valve rubber seals	Valve plug seals	Valve guide rings
Preventive maintenance	Replace after 12 months(*)	Replace after 12 months (*)	Replace when required
Maintenance after leakage (leakage normally starts slowly)	Replace after production cycle	Replace after production cycle	Replace when required
Planned maintenance	<ul style="list-style-type: none"> - regular inspection for leakage and smooth operation - Keep a record of the valve - Use the statistics for planning of inspections 	<ul style="list-style-type: none"> - Regular inspection for leakage and smooth operation - Keep a record of the valve - Use the statistics for planning of inspections 	
Lubrication	When assembling Klüber Paraliq GTE 703 or similar USDA H1 approved oil/grease (**) (suitable for EPDM)	When assembling Klüber Paraliq GTE 703 or similar USDA H1 approved oil/grease (**) (suitable for EPDM)	None

Note!

Lubricate thread in valve plug parts with Klüber Paste UH1 84-201 or similar.

(*) Depending on working conditions! Please contact Alfa Laval.

(**) All product wetted seals.

Repairing of actuator

- The actuator is maintenance-free, but repairable.
- If repair is required, replacing all actuator rubber seals is recommended.
- Lubricate seals with Klüberplex BE31
- To avoid possible black remains on position number 1 and 29. Alfa Laval recommends Klüber Paraliq GTE 703 (white) for these two positions.

Pre-use check

1. Supply compressed air to AC1, AC2 and AC3 one by one
2. Operate the valve several times to ensure that it operates smoothly.

Pay special attention to the warnings!

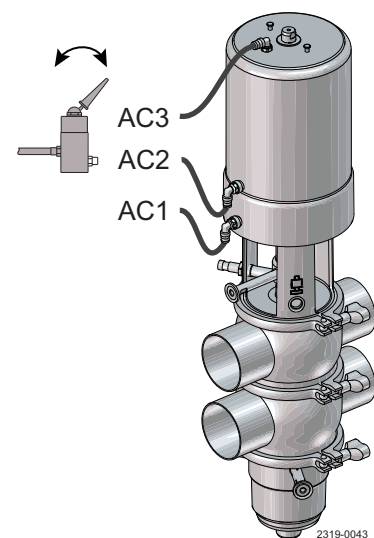

The valve is designed so that internal leakages do not result in the products becoming mixed.

Internal leakage in the valve is externally visible.

Study the instructions carefully.

Always keep spare rubber seals and guide rings in stock. Check the valve for smooth operation after service.

6.2 Dismantling of valve

Step 1

Disassemble valve acc. to illustrations (1 to 6)

1. Supply compressed air to AC2.
2. Loosen and remove upper clamp (64).
3. Release compressed air.
4. Lift out the actuator together with the internal valve parts from valve body (50).
5. Loosen and remove lower clamp (64).
6. Take away lower sealing element (A, B or C).

Note!

Release compressed air.

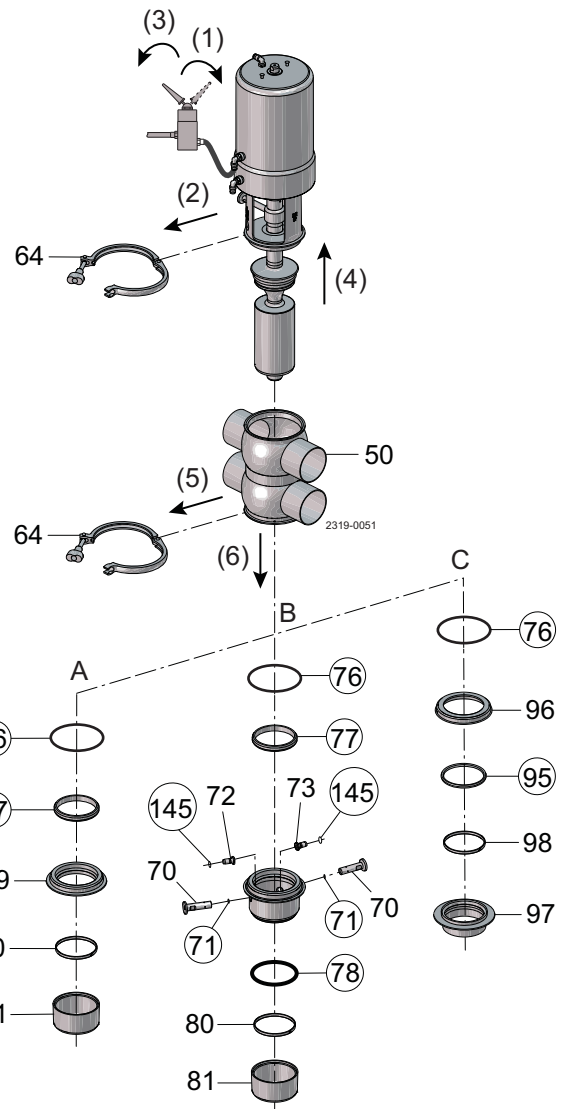

A

Dismantling of lower sealing element

1. Pull out o-ring (76) and lip seal (77).
2. Remove guide ring (80).

B

Dismantling of lower sealing element, balanced with CIP OD balancer

1. Pull out o-ring (76) and lip seal (77).
2. Remove o-ring (78).
3. Remove guide ring (80).
4. Screw out flushing tubes (70).
5. Remove o-rings (71).
6. Remove o-rings (145) and nozzles (72 + 73).

C

Dismantling of lower sealing element, flush OD balancer

1. Remove upper part of sealing element (96)
2. Pull out o-ring (76) and lip seal (95).
3. Remove guide ring (98) from lower part of sealing element (97).

Step 1A - Only applicable when bodies are clamped.

1. Remove clamp (64)
2. Remove valve body (51)
3. Take away o-ring (52) from upper body (51)

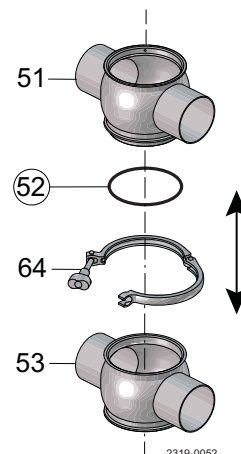

6 Maintenance

The valve is designed so that internal leakages do not result in the products becoming mixed.

Internal leakage in the valve is externally visible.

Study the instructions carefully.

Always keep spare rubber seals and guide rings in stock. Check the valve for smooth operation after service.

Step 2

1. Supply compressed air for air connection AC1.
2. Loosen lower plug (75) while counterholding upper stem (1).
3. Remove the plug.
4. Release compressed air.

Note: For replacement of seal ring (74), please see section 6.3 Lower plug, replacement of radial seal.

1 = on

4 = off

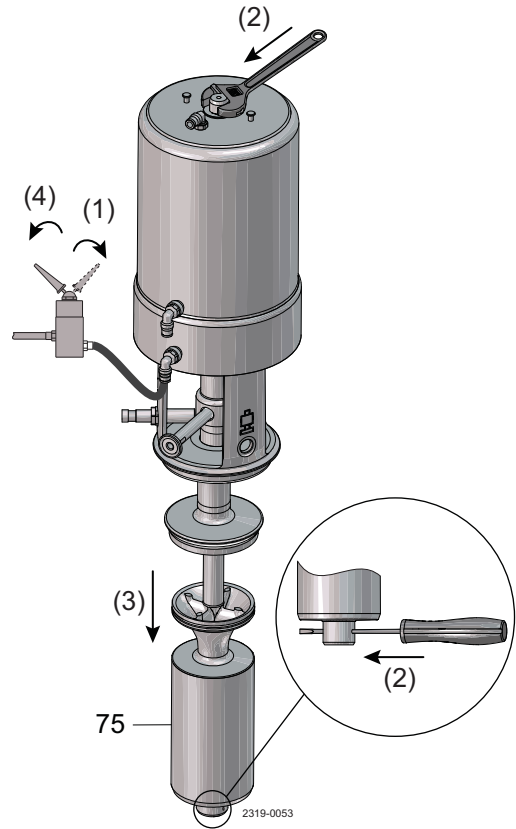

Step 3

Remove coupling system and upper plug according to illustrations (1-4)

1. **No SpiralClean in leakage chamber:**

A. Unscrew plug (15)

SpiralClean in leakage chamber:

A. Unscrew flushing tube (41).

B. Remove o-ring (40)

2. Pull up lock (44) over piston rod (29)
 3. Pull away clamps (43) from spindle liner (42)
 4. Pull out upper plug (55). Make sure spindle liner (42) is free of both piston rod and upper plug.
- SpiralClean in leakage chamber:** Remove both o-rings (39) on valve plug (55) and piston rod (29)

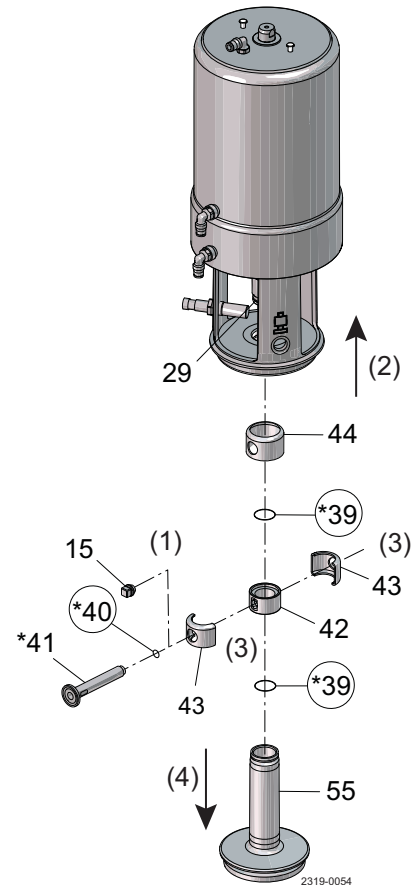

The valve is designed so that internal leakages do not result in the products becoming mixed.

Internal leakage in the valve is externally visible.

Study the instructions carefully.

Always keep spare rubber seals and guide rings in stock. Check the valve for smooth operation after service.

Step 4

A

Dismantling of upper sealing element

1. Remove sealing element (48) from intermediate piece (37).
2. Pull out o-ring (47) and lip seal (49) from sealing element (48)
3. Remove guide ring (45).

B

Dismantling of upper sealing element, CIP OD spindle/balance

1. Screw out flushing tubes (66).
2. Remove o-rings (67)
3. Remove o-rings (144) and nozzles (69 + 68).
4. Remove sealing element (48) from intermediate piece (37)
5. Pull out o-ring (47) and lip seal (49) from sealing element (48).
6. Remove o-ring (46)
7. Remove guide ring (45).

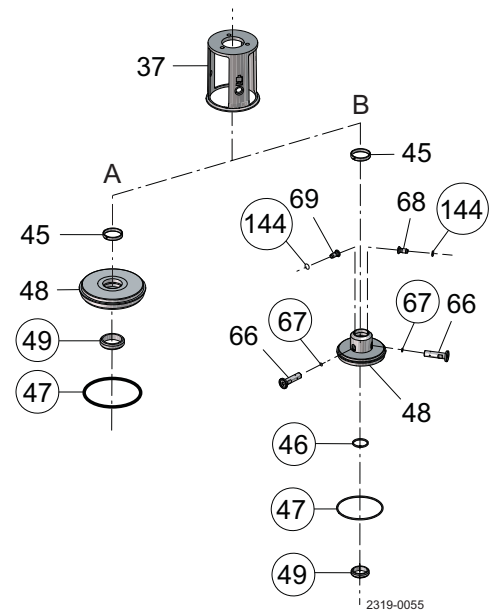

2319-0055

Step 5

Remove lip seal (57) and guide ring (54) (or spray nozzle (58) if valve is supplied with SpiralClean in leakage chamber. For removal and replacement of seal ring (56), please see section 6.4 Upper plug, replacement of axial seal

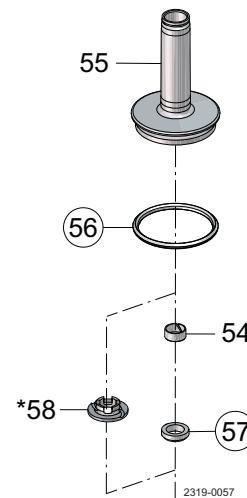

2319-0057

6 Maintenance

The valve is designed so that internal leakages do not result in the products becoming mixed.

Internal leakage in the valve is externally visible.

Study the instructions carefully.

Always keep spare rubber seals and guide rings in stock. Check the valve for smooth operation after service.

6.3 Lower plug, replacement of radial seal

Step 1

Cut and remove old seal ring (74) using a knife, screwdriver or similar. Be careful not to scratch the plug.

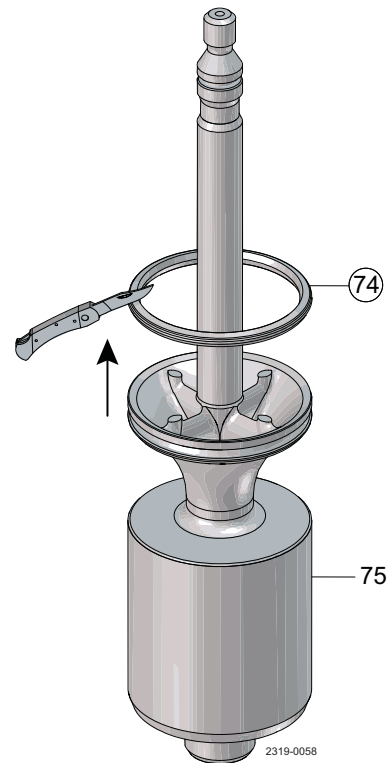

Step 2

Pre-mount seal ring as shown on drawing.

Rotate along circumference to fix sealing as shown in the picture.

Carefully lubricate sealings with suitable soap or lubricant (Klüber Paraliq GT 703), before pre-mounting.

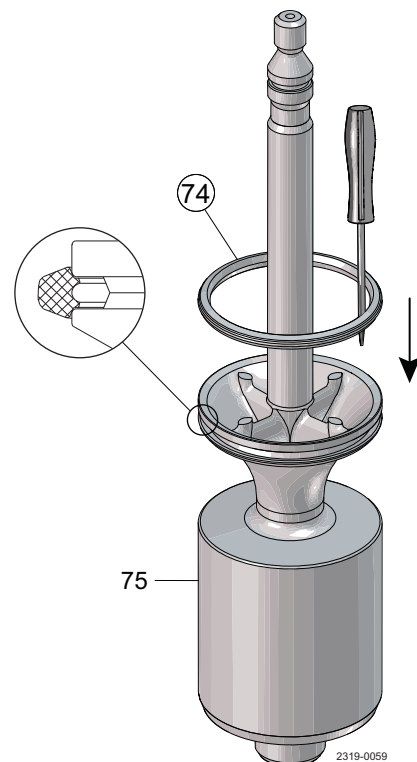

6 Maintenance

The valve is designed so that internal leakages do not result in the products becoming mixed.
 Internal leakage in the valve is externally visible.
 Study the instructions carefully.
 Always keep spare rubber seals and guide rings in stock. Check the valve for smooth operation after service.

Step 3

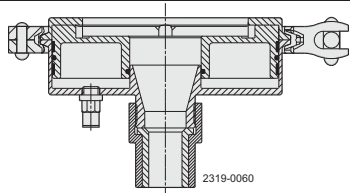
Item no.	Item no.	Item no.	Item no.	Tool for radial sealing, lower plug
1½" + 2"	2½" + 3"	4"	6"	
9613-4260-01	9316-4260-02	9613-4260-03	9613-4260-04	

Step 4

Place lower tool part.

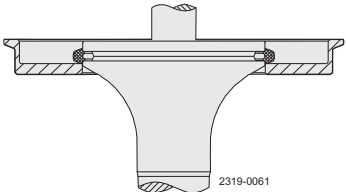

Step 5

1. Place upper tool part including piston.
2. Clamp the two tool parts together.

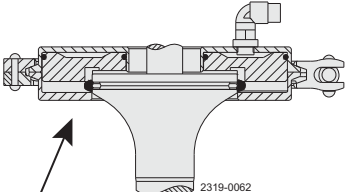

Tool marked with item number.

Step 6

1. Supply compressed air.
2. Release compressed air.
3. Remove tool parts.

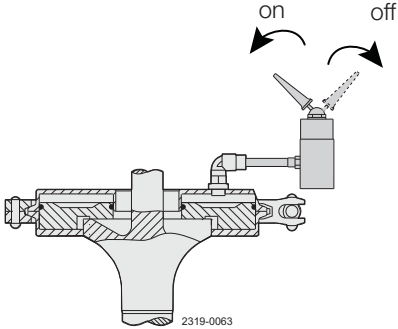

6 Maintenance

The valve is designed so that internal leakages do not result in the products becoming mixed.

Internal leakage in the valve is externally visible.

Study the instructions carefully.

Always keep spare rubber seals and guide rings in stock. Check the valve for smooth operation after service.

Step 7

Inspect the seal to ensure it does not twist in the groove, and press in the 4 outsticking points with a screwdriver

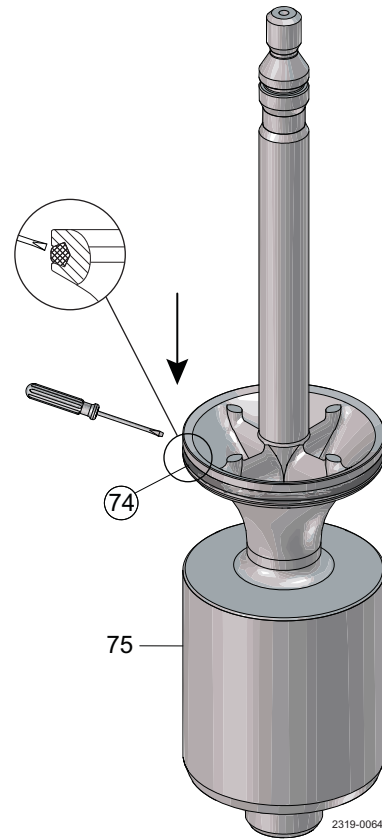

The valve is designed so that internal leakages do not result in the products becoming mixed.

Internal leakage in the valve is externally visible.

Study the instructions carefully.

Always keep spare rubber seals and guide rings in stock. Check the valve for smooth operation after service.

6.4 Upper plug, replacement of axial seal

Step 1

Remove old seal ring (56) using a knife, screwdriver or similar. Be careful not to scratch the plug.

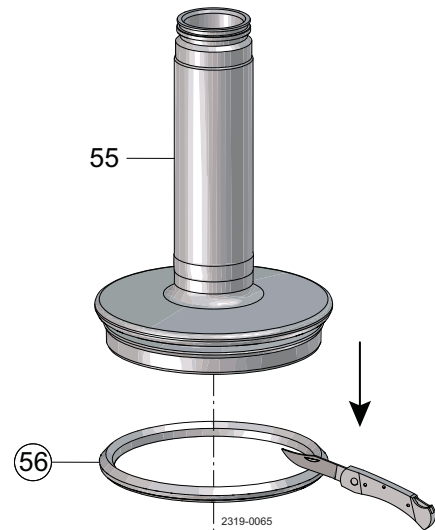

Step 2

Pre-mount seal ring as shown on drawing.

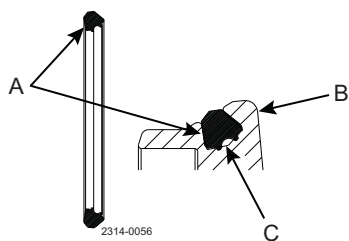

- A = Flat side of the sealing
- B = Balanced plug
- C = Do not lubricate behind the sealing

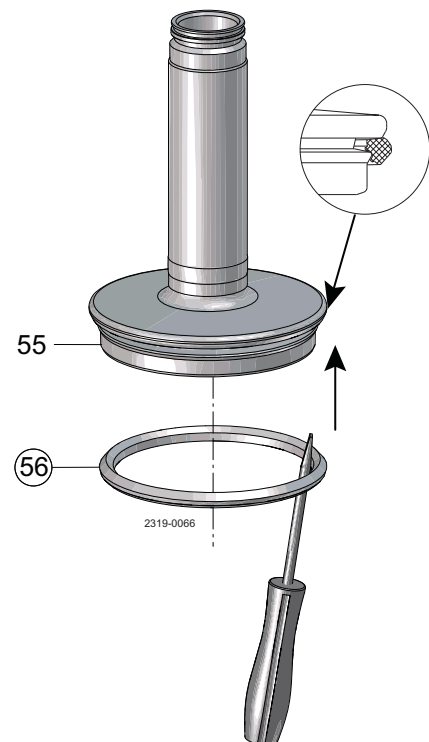

Carefully lubricate sealings with suitable soap or lubricant (Klüber Paraliq GT 703), before pre-mounting.

6 Maintenance

The valve is designed so that internal leakages do not result in the products becoming mixed.

Internal leakage in the valve is externally visible.

Study the instructions carefully.

Always keep spare rubber seals and guide rings in stock. Check the valve for smooth operation after service.

Step 3

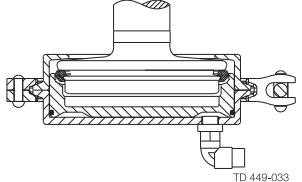
Item no.	Item no.	Item no.	Item no.	Tool for axial sealing, upper plug
1½" + 2"	2½" + 3"	4"	6"	
9613-0505-01	9613-0505-02	9613-0505-08	9613-0505-03	

Step 4

Place tool part 1.

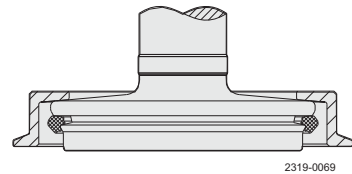

Step 5

1. Place tool part 2 including piston.
2. Clamp the two tool parts together.

Tooling marked with item number

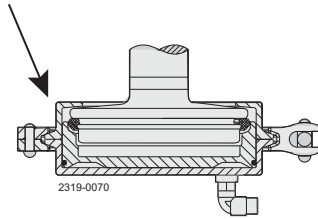

Step 6

1. Supply compressed air.
2. Release compressed air.
3. Rotate the tool 45° in relation to the plug.
4. Supply compressed air.
5. Release compressed air and remove tool.

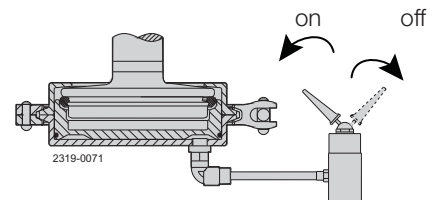

Step 7

1. Inspect the seal.
2. Release air at 3 different positions of the circumference.

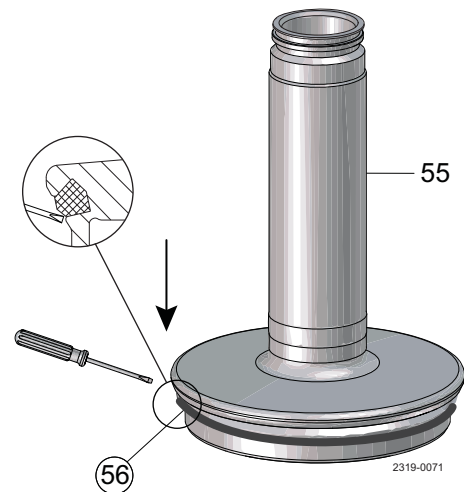

The valve is designed so that internal leakages do not result in the products becoming mixed.

Internal leakage in the valve is externally visible.

Study the instructions carefully.

Always keep spare rubber seals and guide rings in stock. Check the valve for smooth operation after service.

6.5 Assembly of valve

Step 1

A

Assembly of upper sealing element

1. Fit o-ring (47) (do not twist), and lip seal (49) in upper sealing element (48) (Lubricate with Klüber Paraliq GT 703).

NOTE: The o-ring should be gently pressed into the groove.

2. Fit guide ring (45) in upper sealing element.
3. Fit upper sealing element in intermediate piece (37).

B

Assembly of upper sealing element, CIP OD spindle/balancer

1. Fit o-ring (47) (do not twist), lip seal (49) and o-ring (46) in upper sealing element (48) (lubricate with Klüber Paraliq GT 703)

NOTE: The o-ring should be gently pressed into the groove.

2. Fit guide ring (45) in upper sealing element.
3. Fit upper sealing element in intermediate piece (37).
4. Place o-rings (67+144) and mount flushing tubes (66). Be sure to align nozzles (68 + 69) towards recess.

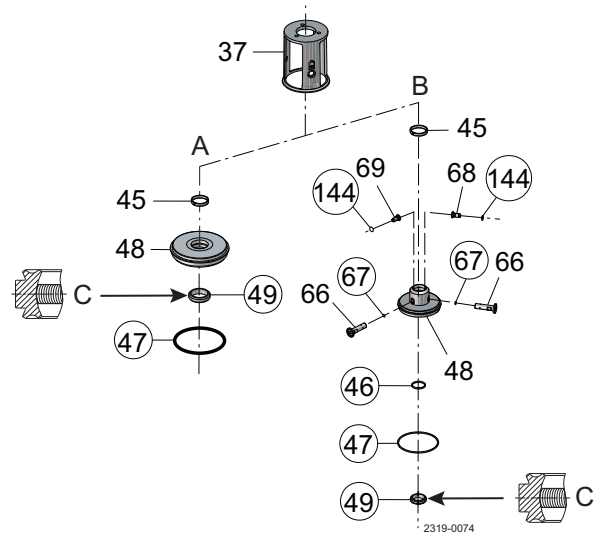

C = Lubricate with Klüber Paraliq GT 703 on ID

Step 2

1. Place guide ring (54) and lip seal (57) in upper plug or nozzle (58) by SpiralClean in leakage chamber.

2. Mount o-ring (38) in lower plug.

3. Press lower plug (75) rapidly into upper plug (55) through the lip seal.

Note: Do not damage the lips when lower plug (75) with o-ring (38) passes the lip seal.

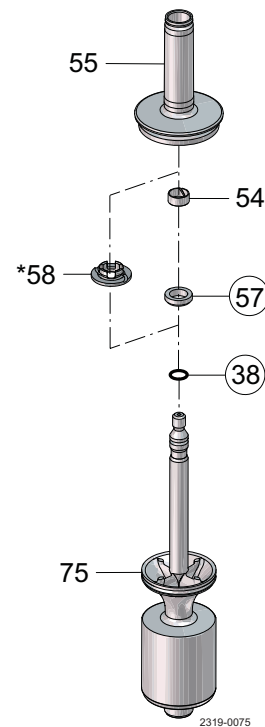

6 Maintenance

The valve is designed so that internal leakages do not result in the products becoming mixed.

Internal leakage in the valve is externally visible.

Study the instructions carefully.

Always keep spare rubber seals and guide rings in stock. Check the valve for smooth operation after service.

Step 3

Place coupling system and upper plug according to illustrations.

1. Push lock (44) up over piston rod (29).
2. If SpiralClean in leakage chamber: place o-rings (39) in groove on upper plug (55) and piston rod (29).
3. Place spindle liner (42) on piston rod (29). Fit upper plug (55).
4. Mount clamps (43) on spindle liner (42).
5. Fit lock (44).
6. Fit plug (15) or flushing tube (41) and o-ring (40) if SpiralClean in leakage chamber.

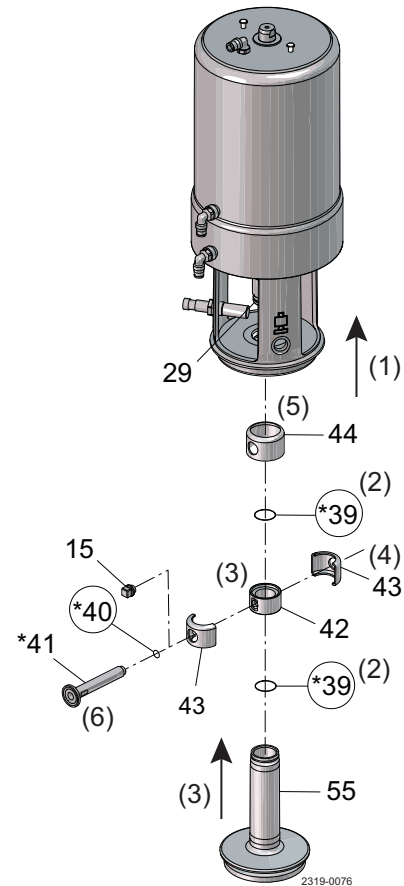

Step 4

1. Supply compressed air for air connection AC1
2. Insert lower plug (75) and tighten
3. Release compressed air

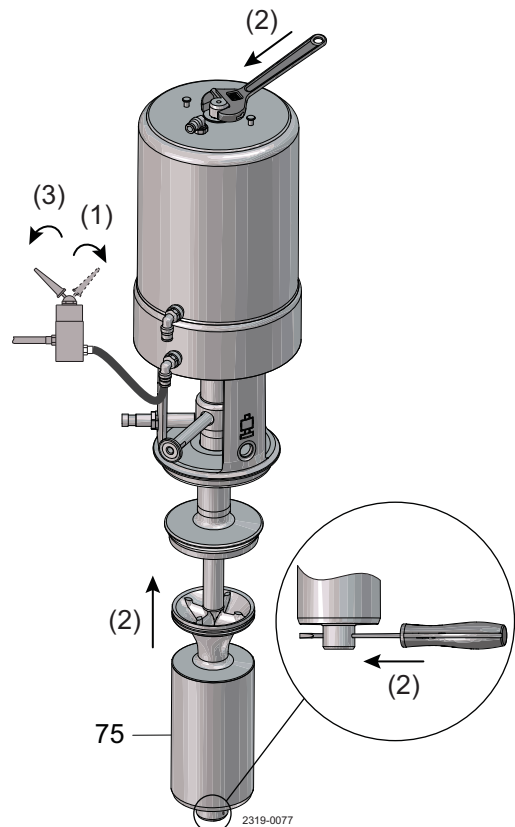

The valve is designed so that internal leakages do not result in the products becoming mixed.

Internal leakage in the valve is externally visible.

Study the instructions carefully.

Always keep spare rubber seals and guide rings in stock. Check the valve for smooth operation after service.

Step 5

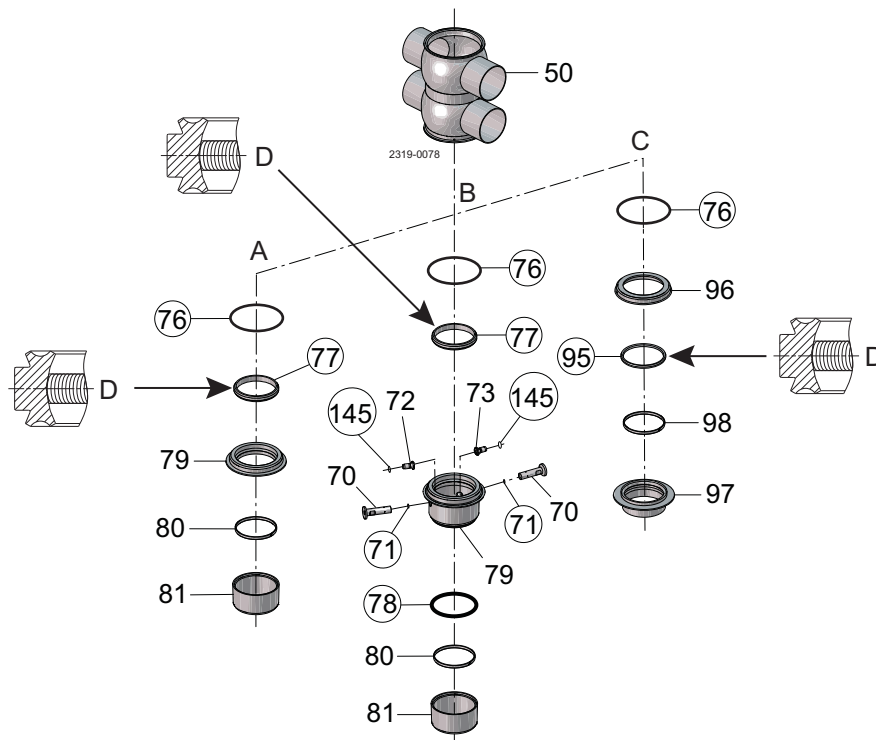

D = Lubricate with Klüber Paraliq GT 703 on ID

A - Assembly of lower sealing element

1. Fit lip seal (77) and o-ring (76) (do not twist the o-ring) and press it gently into the groove (lubricate with Klüber Paraliq GT 703)
2. Fit guide ring (80) into sealing element (79)

B - Assembly of lower sealing element with CIP OD balancer

1. Fit o-ring (76) (do not twist), lip seal (77) and o-ring (78) in lower sealing element (lubricate with Klüber Paraliq GT 703).
Note! The o-ring (76) should be gently pressed into the groove.
2. Fit guide ring (80) in lower sealing element.
3. Place o-rings (71+ 145) and mount flushing tubes (70). Be sure to align nozzles (72 + 73) towards recess.

C - Assembly lower sealing element with flush OD balancer

1. Fit o-ring (76) (do not twist the o-ring) in upper part of sealing element (lubricate with Klüber Paraliq GT 703).
Note! The o-ring should be gently pressed into the groove.
2. Place guide ring (98) in lower part of sealing element (97).
3. Fit lip seal (95) in sealing element (97).
4. Place upper part of sealing element (96) on top of lower part of sealing element (97).

Step 5B

Only applicable when bodies are clamped

1. Fit o-ring (52) into groove in upper body (51)
Lubricate with Klüber Paraliq GT 703)
2. Mount upper body (51) in lower (53)
3. Fit and tighten clamp (64), greasing of clamp and clamp nut recommended.
(Maximum torque for clamp not 10Nm/7,4 lbf-ft)

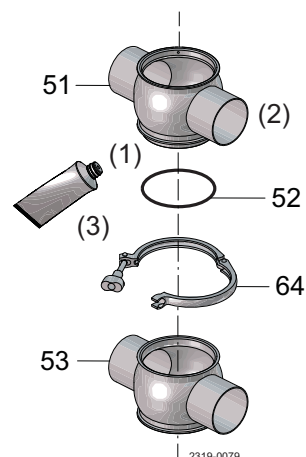

2319-0079

6 Maintenance

The valve is designed so that internal leakages do not result in the products becoming mixed.

Internal leakage in the valve is externally visible.

Study the instructions carefully.

Always keep spare rubber seals and guide rings in stock. Check the valve for smooth operation after service.

Step 6

- **Never** stick your fingers through the valve ports if the actuator is supplied with compressed air.
- **Always** supply compressed air, before demounting the valve.

1. Fit lower sealing element (A, B or C)
2. Fit and tighten lower clamp (64)
3. Supply compressed air and mount the actuator together with the internal valve parts from valve body (50)
4. Fit and tighten upper clamp (64). Lubricating of clamp and clamp nut recommended!
(Maximum torque for clamp nut: 10Nm/7.4 lbf-ft)
5. Release compressed air.

Note!

Supply compressed air before mounting the valve.

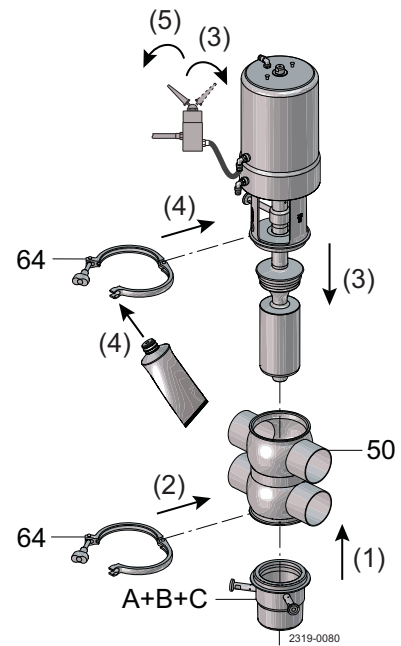

6 Maintenance

The valve is designed so that internal leakages do not result in the products becoming mixed.
Internal leakage in the valve is externally visible.

Study the instructions carefully.

Always keep spare rubber seals and guide rings in stock. Check the valve for smooth operation after service.

6.6 Dismantling of actuator

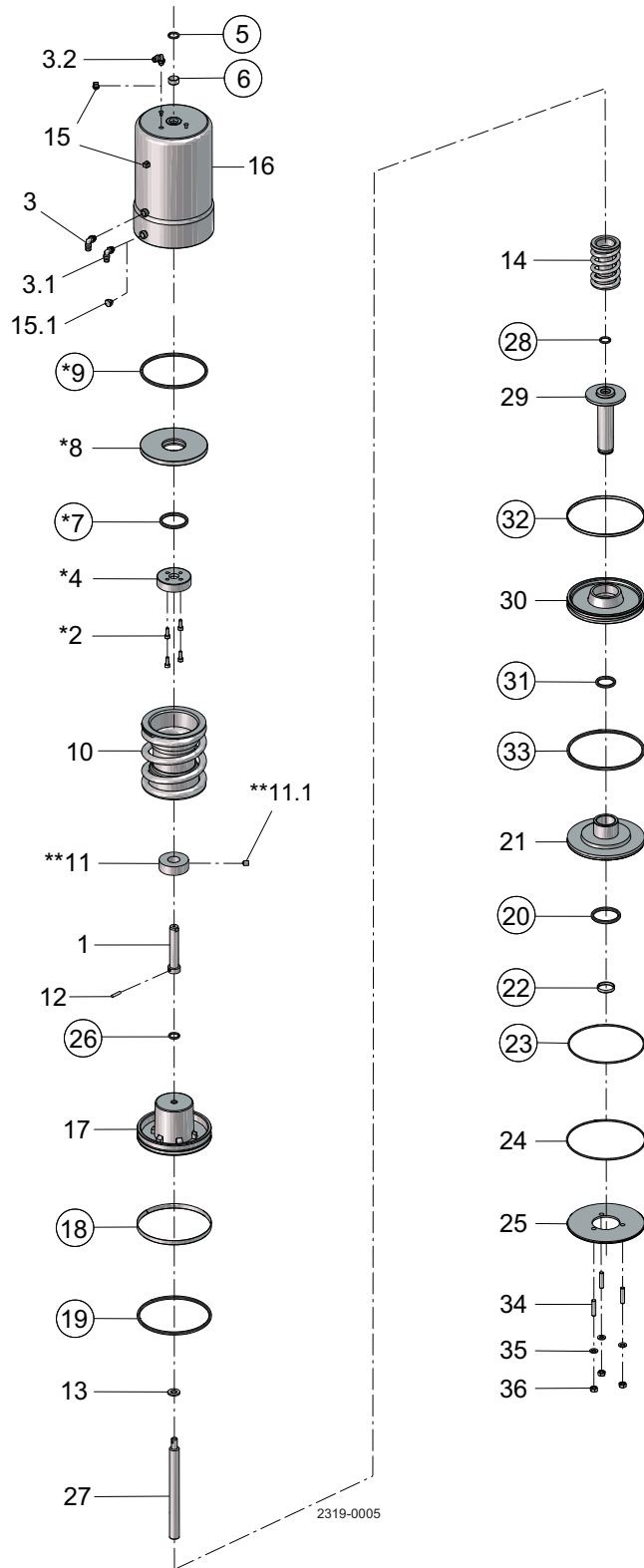

The valve is designed so that internal leakages do not result in the products becoming mixed.

Internal leakage in the valve is externally visible.

Study the instructions carefully.

Always keep spare rubber seals and guide rings in stock. Check the valve for smooth operation after service.

Step 1

1. Dismantle the valve in accordance with instructions in section 6.1 General maintenance

Pay special attention to the warnings!

2. The actuator is now ready for service. Please see drawing when dismantling according to steps 2 to 6 on this page.

Note! The actuator is maintenance free but repairable.

Step 2

1. Remove nuts (36) and washers (35).
 2. Pull out intermediate piece (37) from the actuator.
 3. Remove cover disk (25).
 4. Remove retaining ring (24).
-

Step 3

1. Remove piston rod (29), bottom (21) and lower piston (30).
 2. Separate the three parts.
 3. Remove o-rings (20, 22 and 23) from bottom, o-rings (33 and 31) and guide ring (32) from lower piston as well as o-ring (28) from piston rod.
 4. Remove spring assembly (14).
-

Step 4

1. Remove inner stem (27), main piston (17) and distance spacer and screw (11/11.1) (only on 1½" and 2").
Remove guide ring (18) and o-ring (19)
 2. Remove spring assembly (10).
-

Step 5

Note! Not on actuator 1½" and 2"

1. Unscrew screws (2) (are glued!).
 2. Remove stop (4).
 3. Remove upper piston (8). Remove o-rings (7 and 9).
-

Step 6

1. Remove o-ring (5) and guide ring (6).
-

6 Maintenance

The valve is designed so that internal leakages do not result in the products becoming mixed.
Internal leakage in the valve is externally visible.

Study the instructions carefully.

Always keep spare rubber seals and guide rings in stock. Check the valve for smooth operation after service.

6.7 Assembly of actuator

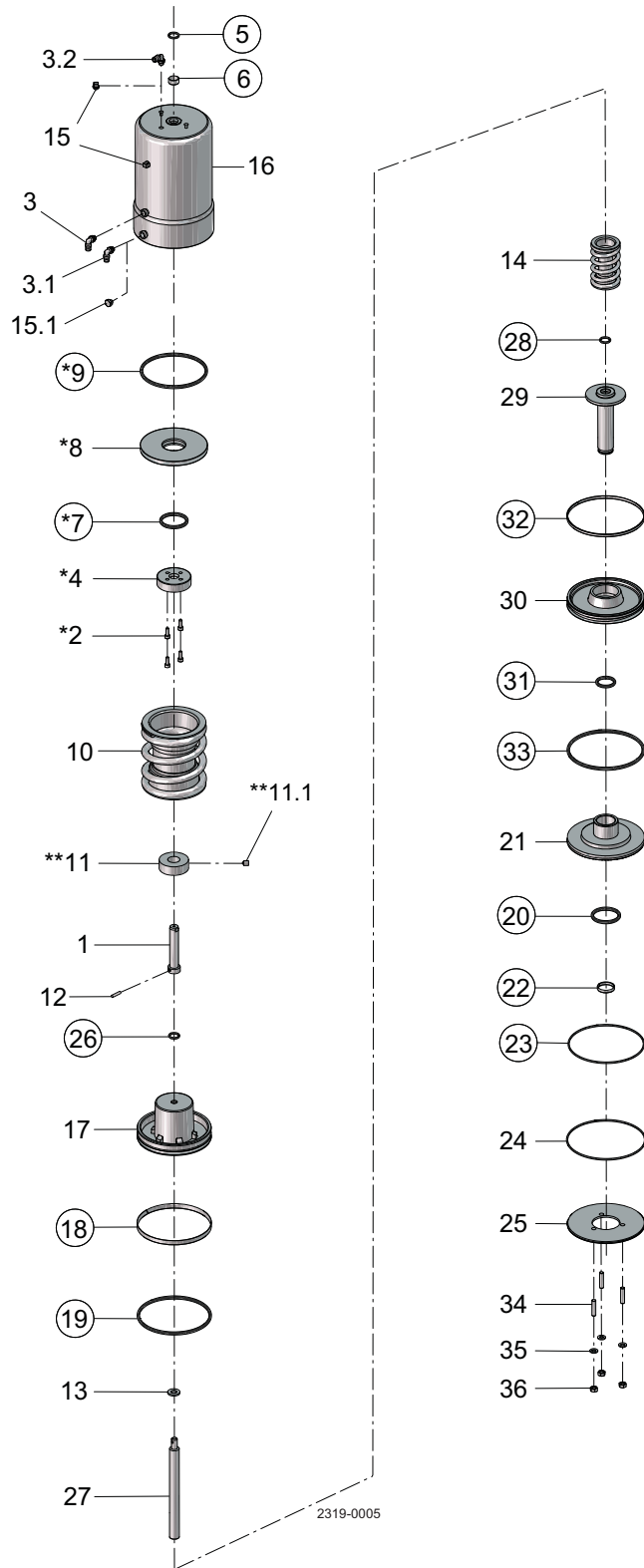

The valve is designed so that internal leakages do not result in the products becoming mixed.

Internal leakage in the valve is externally visible.

Study the instructions carefully.

Always keep spare rubber seals and guide rings in stock. Check the valve for smooth operation after service.

Step 1

Please see drawing when reassembling according to steps 2 to 6 on this page.

Note! The actuator is maintenance free but repairable.

Step 2

1. Fit guide ring (6) and o-ring (5).
-

Step 3

Note! Not on actuator 1½" and 2"

1. Fit o-rings (7 and 9). Place upper piston (8).
 2. Fit stop (4).
 3. Tighten screws (2). (Secure with glue)
-

Step 4

1. Place spring assembly (10).
 2. Fit o-ring (19) and guide ring (18). Mount distance spacer (11) and screw (11.1) (only on 1½" and 2"), main piston (17) and inner stem (27).
-

Step 5

1. Fit spring assembly (14).
 2. Fit o-ring (28) in piston rod, fit o-rings (33 and 31) and guide ring (32) in lower piston and fit o-rings (20, 22 and 23) in bottom.
 3. Fit piston rod (29), lower piston (30) and bottom (21).
 4. Mount the three parts.
-

Step 6

1. Fit retaining ring (24).
2. Fit cover disk (25).
3. Mount intermediate piece (37) on actuator.
4. Fit and tighten nuts (36) and washers (35).

6 Maintenance

The valve is designed so that internal leakages do not result in the products becoming mixed.

Internal leakage in the valve is externally visible.

Study the instructions carefully.

Always keep spare rubber seals and guide rings in stock. Check the valve for smooth operation after service.

Placement of external sensor and sensor type

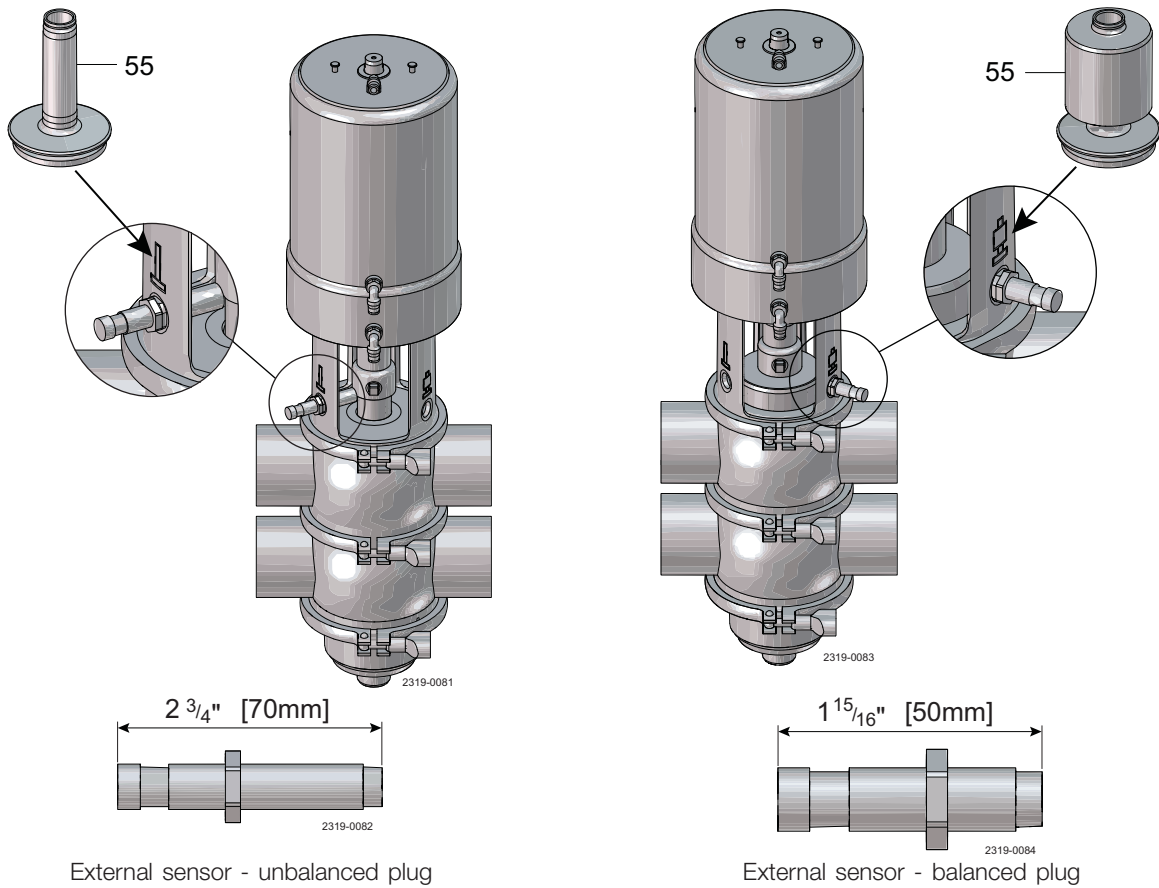

7.1 Technical data

Data	
Max. product pressure	145 psi
Min. product pressure	Full vacuum
Recommended min. pressure for SpiralClean	29 psi
Temperature range	23°F - 257°F (Depending on rubber quality)
Air pressure	116 psi
Materials	
Product wetted steel parts	Acid-resistant steel AISI 316
Other steel parts	Stainless steel AISI 304
Product wetted parts	EPDM, HNBR, NBR or FPM
Other seals	CIP seals: EPDM
Actuator seals	NBR
Surface finish	Internal bright (polished) Ra < 0.8 (32 μm)/external matt (blasted Ra < 1.6/64μm) Internal/external bright (internal polished) Ra < 0.8 (32 μm)

Note!

The Ra-values are only for the internal surface.

Recommended minimum pressure for SpiralClean: 30 psi/flow rate 4.2 gpm

Formula to estimate CIP flow during seat lift (for liquids with comparable viscosity and density to water)

$$Q = C_v \cdot \sqrt{\Delta p}$$

Q = CIP - flow (gpm)

Cv = Cv value from the above table

Δp = CIP pressure (psi)

Assumption: density = 1

Size	1½"	2"	½"	3"	4"	6"
Cv-value - upper seat-lift [gpm/psi]	2.9	2.9	4.3	4.3	5.3	6.3
Cv-value - lower seat-lift [gpm/psi]	2.2	2.2	3.6	3.6	4.9	6.1
Air consumption - upper seat-lift *[cubic inches]	12	12	24	24	38	38
Air consumption - lower seat-lift *[cubic inches]	6.7	6.7	8	8	13	13
Air consumption - main movement *[cubic inches]	52	52	99	99	170	170
Cv-value SpiralClean - spindle CIP [gpm/psi]	0.14	0.14	0.14	0.14	0.14	0.14
Cv-value SpiralClean - external CIP of leakage chamber [gpm/psi]	0.29	0.29	0.34	0.34	0.34	0.34

For further information concerning cleaning of the valve, please see section 4.2 Recommended cleaning, step 5, 6, 7 & 8.

Noise

5¼ Ft above the exhaust the noise level of a valve actuator will be approximately 77db(A) without noise damper and approximately 72 db(A) with damper - Measured at 102 psi air-pressure.

8 Parts list and service kits

For spare parts please refer to spare parts catalogue.

8.1 Actuator

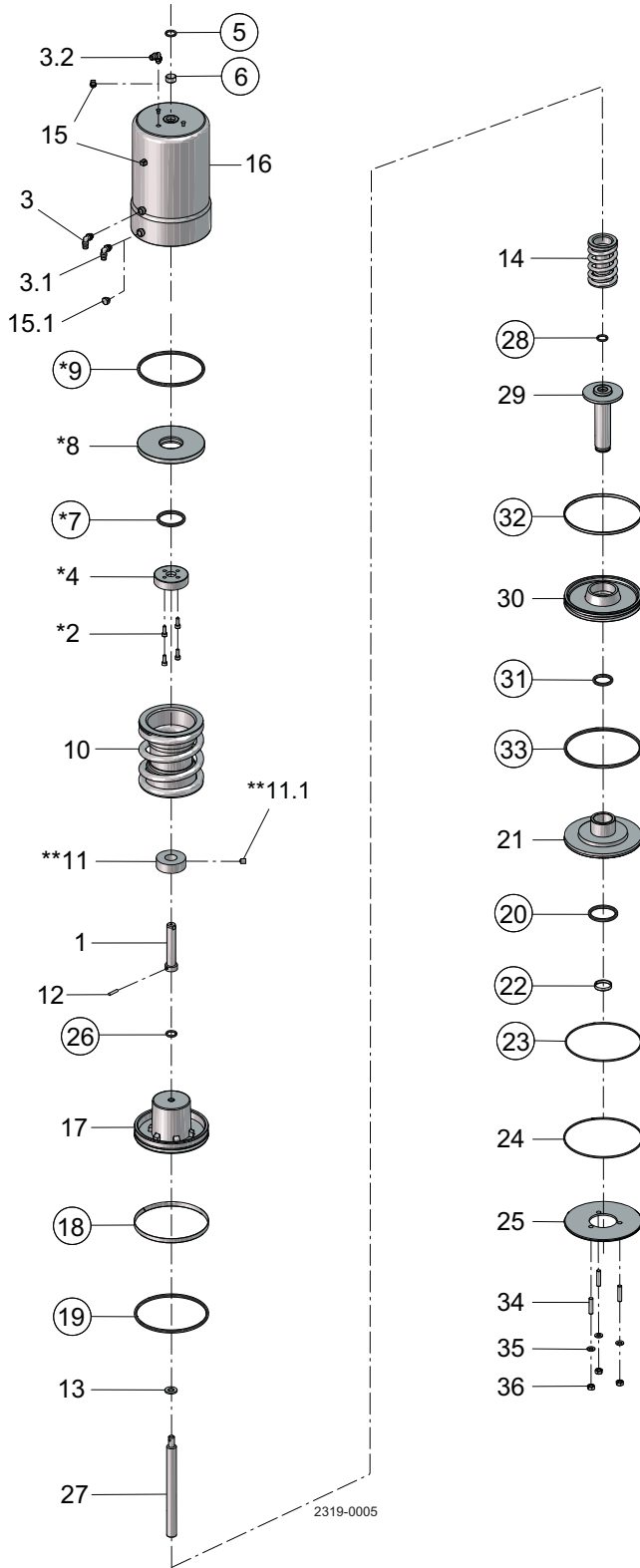

- = acuator service kit
- * = not used in actuator 1½" - 2"
- ** = not used in actuator 2½", 3", 4 and 6"

8 Parts list and service kits

For spare parts please refer to spare parts catalogue.

Parts list

Pos.	Qty	Denomination
1	1	Upper stem
2	4	Screw
3	1	Air fitting blue
3.1	1	Air fitting red
3.2	1	Air fitting yellow
4	1	Stop for upper piston
5	1	O-ring, NBR
6	1	Guide ring, Turcite
7	1	O-ring, NBR
8	1	Upper piston
9	1	O-ring, NBR
10	1	Spring assembly
11	1	Distance spacer
11.1	1	Screw
12	1	Pin
13	1	Washer
14	1	Spring assembly
15	2	Plug
15.1	1	Plug
17	1	Main piston
18	1	Guide ring, Turcite
19	1	O-ring, NBR
20	1	O-ring, NBR
21	1	Bottom
22	1	Guide ring, Turcite
23	1	O-ring, NBR
24	1	Retaining ring
25	1	Cover disk
26	1	O-ring, NBR
27	1	Inner stem
28	1	O-ring
29	1	Piston rod
30	1	Lower piston
31	1	O-ring, NBR
32	1	Guide ring, Turcite
33	1	O-ring, NBR
34	3	Bolt
35	3	Washer
36	3	Nut

Service kits

Denomination	1½"	2"	2½"	3"	4"	6"
	Seat ø53.3	Seat ø53.3	Seat ø81.3	Seat ø81.3	Seat ø100.3	Seat ø115.3

Service kits

Actuator service kit	9611-92-6414	9611-92-6414	9611-92-6415	9611-92-6415	9611-92-6416	9611-92-6416
----------------------	-------	--------------	--------------	--------------	--------------	--------------	--------------

8 Parts list and service kits

For spare parts please refer to spare parts catalogue.

8.2 Plug setup overview

Plug setup 3

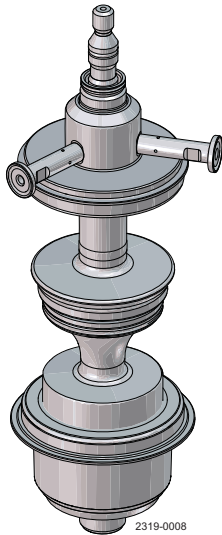

Upper: Unbalanced with SpiralClean OD spindle
Lower: Balanced (blue bottom)
See page 70

Plug setup 4

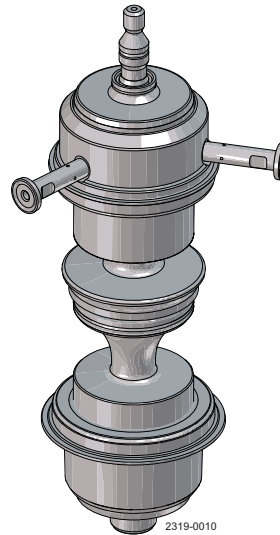

Upper: Balanced with SpiralClean OD balancer
Lower: Balanced (blue bottom)
See page 74

Plug setup 5

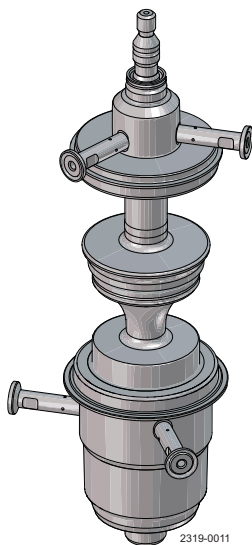

Upper: Unbalanced with SpiralClean OD spindle
Lower: Balanced with SpiralClean OD balancer (blue bottom)
See page 78

Plug setup 6

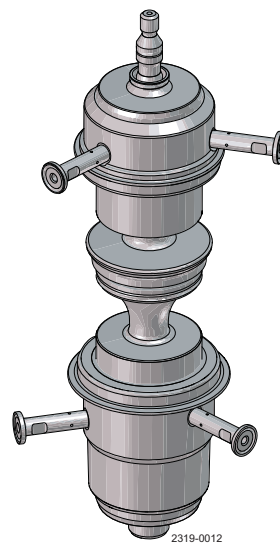

Upper: Balanced with SpiralClean OD balancer
Lower: Balanced with SpiralClean OD balancer (blue bottom)
See page 82

For spare parts please refer to spare parts catalogue.

Plug setup 11

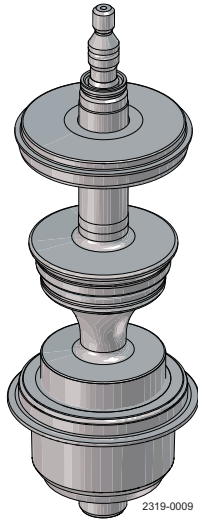

Upper: Unbalanced
Lower: Balanced (blue bottom)
See page 86

Plug setup 12

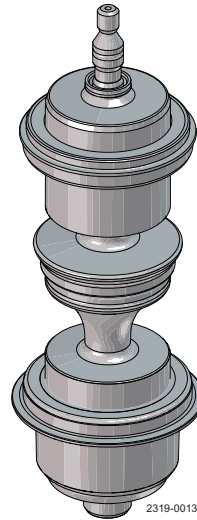

Upper: Balanced
Lower: Balanced (blue bottom)
See page 90

Plug setup 13

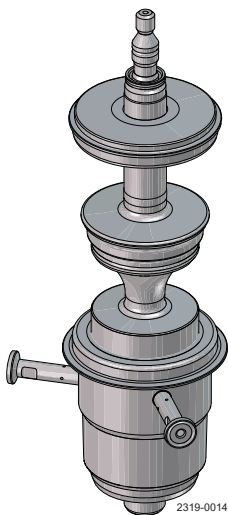

Upper: Unbalanced
Lower: Balanced with SpiralClean OD balancer (blue bottom)
See page 94

Plug setup 14

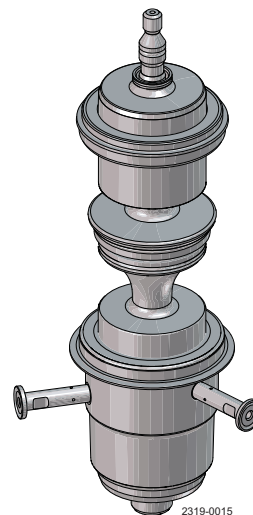

Upper: Balanced
Lower: Balanced with SpiralClean OD balancer (blue bottom)
See page 98

For spare parts please refer to spare parts catalogue.

Plug setup 17

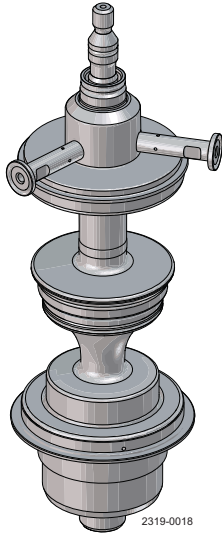

Upper: Unbalanced with SpiralClean OD spindle
Lower: Flush OD Balancer (steel bottom)
See page 102

Plug setup 18

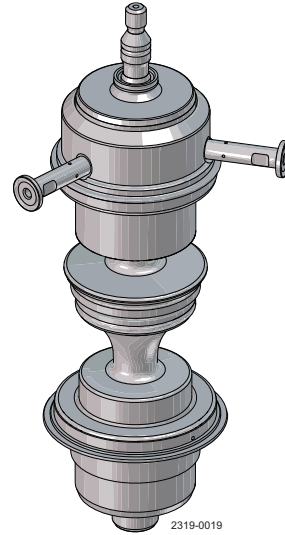

Upper: Balanced with SpiralClean OD balancer
Lower: Flush OD Balancer (steel bottom)
See page 106

Plug setup 19

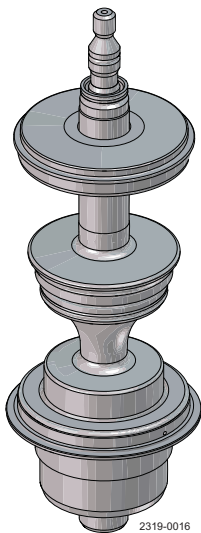

Upper: Unbalanced
Lower: Flush OD Balancer (steel bottom)
See page 110

Plug setup 20

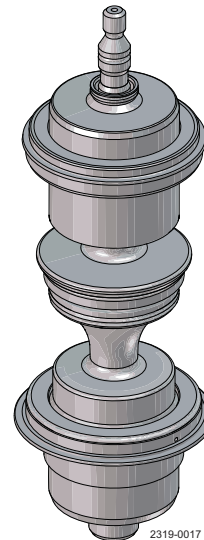

Upper: Balanced
Lower: Flush OD Balancer (steel bottom)
See page 114

8 Parts list and service kits

For spare parts please refer to spare parts catalogue.

8.3 Plug setup 3

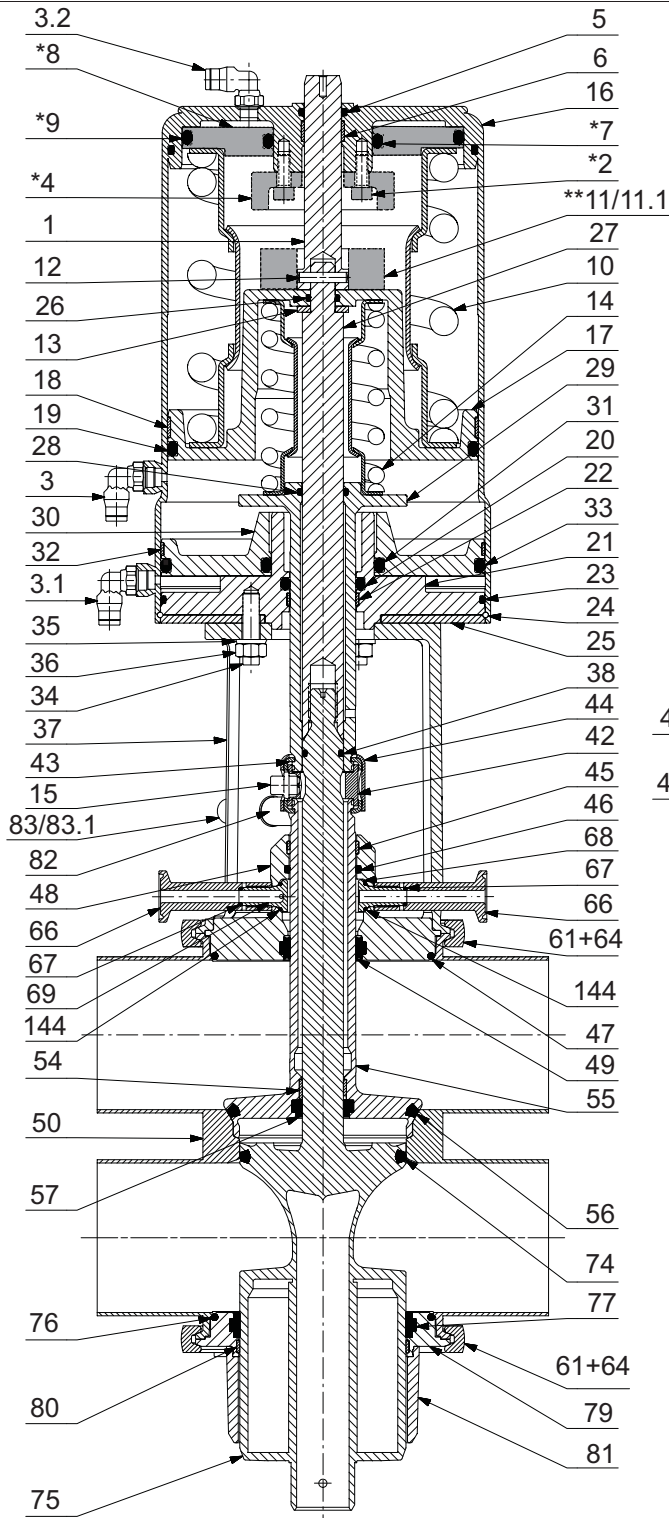

without SpiralClean in leakage chamber

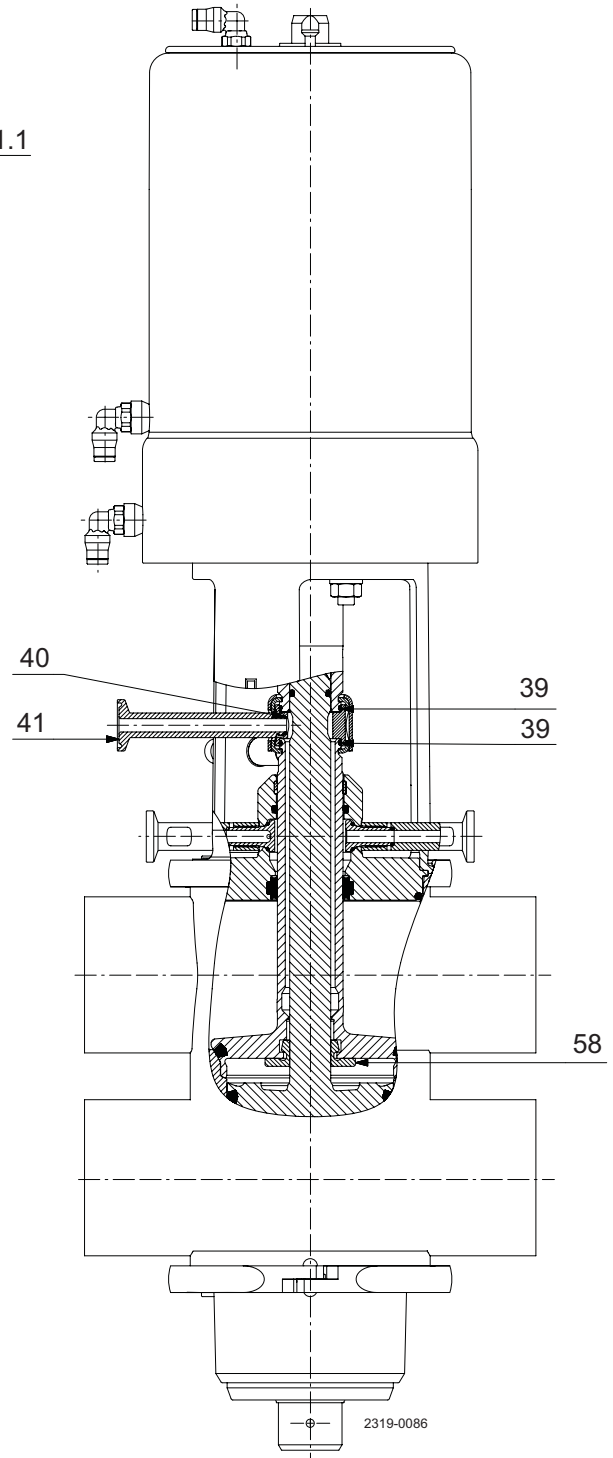

with SpiralClean in leakage chamber

- = Parts not used in all actuators
- * = Not used in 1½" and 2"
- ** = Not used in 2½", 3", 4" and 6"

8 Parts list and service kits

For spare parts please refer to spare parts catalogue.

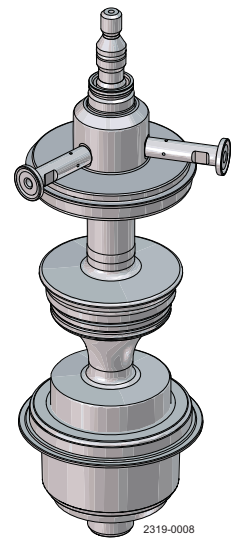
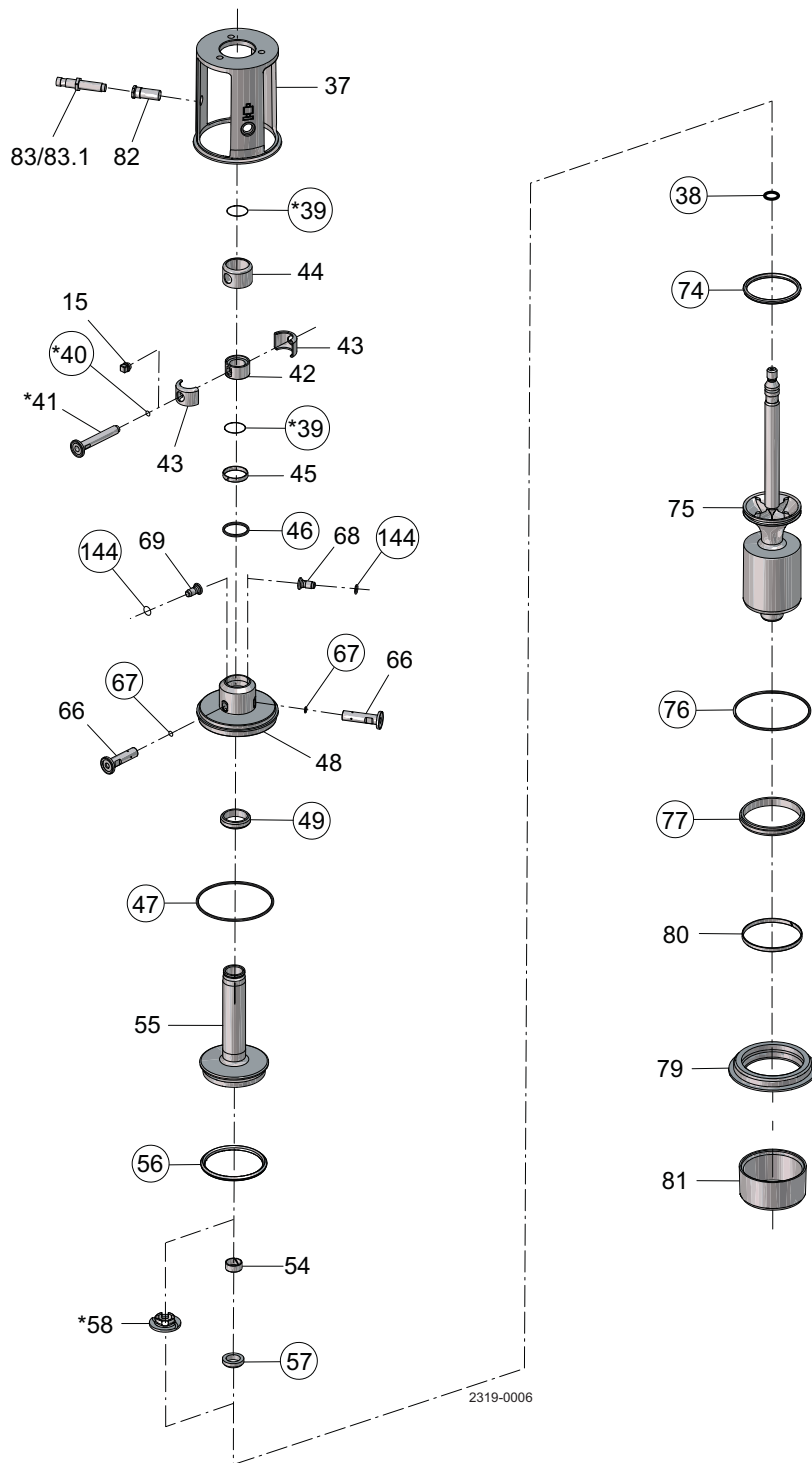

8 Parts list and service kits

For spare parts please refer to spare parts catalogue.

Parts list

Pos.	Qty	Denomination
15	1	Plug
37	1	Intermediate piece
38	1	O-ring
39	2	O-ring
40	1	O-ring
41	1	Flushing tube
42	1	Spindle liner
43	2	Clamp
44	1	Lock
45	1	Guide ring
46	1	O-ring
47	1	O-ring
48	1	Upper sealing element
49	1	Lip seal
52	1	O-ring
54	1	Guide ring
55	1	Upper plug
56	1	Seal ring
57	1	Lip seal
58	1	Spray nozzle
66	2	Flushing tube
67	2	O-ring
68	1	Drain
69	1	Nozzle
74	1	Seal ring
75	1	Lower plug
76	1	O-ring
77	1	Lip seal
79	1	Lower sealing element
80	1	Guide ring
81	1	Cover
82	1	Bolt for indication
83	1	Sensor for indication
83.1	1	Cable for sensor for indication
144	2	O-ring

Service kits

Denomination	2" seat ø53.3	2½" seat ø81.3	3" seat ø81.3	4" seat ø100.3	6" seat ø115.3
Service kit, EPDM	9611-92-8001	9611-92-8005	9611-92-8005	9611-92-8009	9611-92-8013
Service kit, NBR	9611-92-8002	9611-92-8006	9611-92-8006	9611-92-8010	9611-92-8014
Service kit, FPM	9611-92-8003	9611-92-8007	9611-92-8007	9611-92-8011	9611-92-8015
Service kit, HNBR	9611-92-8004	9611-92-8008	9611-92-8008	9611-92-8012	9611-92-8016

For mixed size housings, the service kit is determined by the smallest size connection on the valve.

One exception is any housing with 6" connections will always refer to the 6" service kits listed below:

Service kit, EPDM	9611-92-8125	9611-92-8129	9611-92-8129	9611-92-8133
Service kit, NBR	9611-92-8126	9611-92-8130	9611-92-8130	9611-92-8134
Service kit, FPM	9611-92-8127	9611-92-8131	9611-92-8131	9611-92-8135
Service kit, HNBR	9611-92-8128	9611-92-8132	9611-92-8132	9611-92-8136

8 Parts list and service kits

For spare parts please refer to spare parts catalogue.

8.4 Plug setup 4

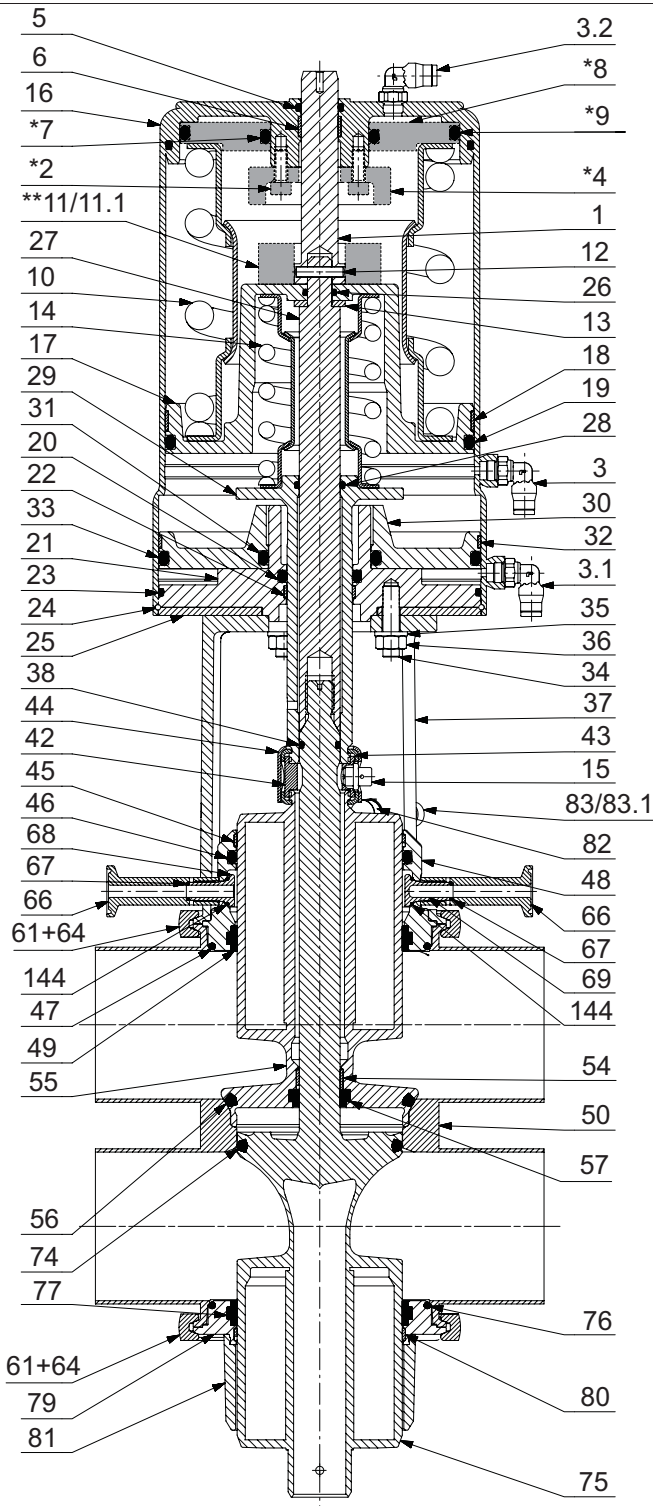

without SpiralClean in leakage chamber

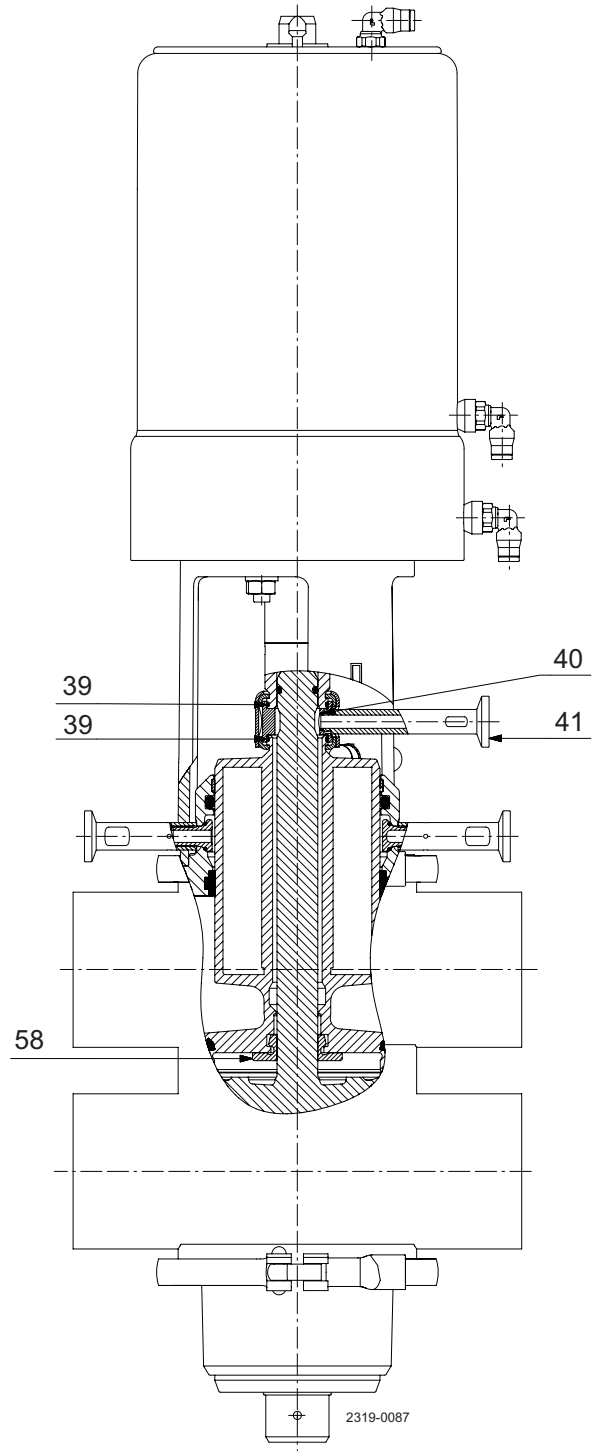

with SpiralClean in leakage chamber

- = Parts not used in all actuators
- * = Not used in 1½" and 2"
- ** = Not used in 2½", 3", 4" and 6"

8 Parts list and service kits

For spare parts please refer to spare parts catalogue.

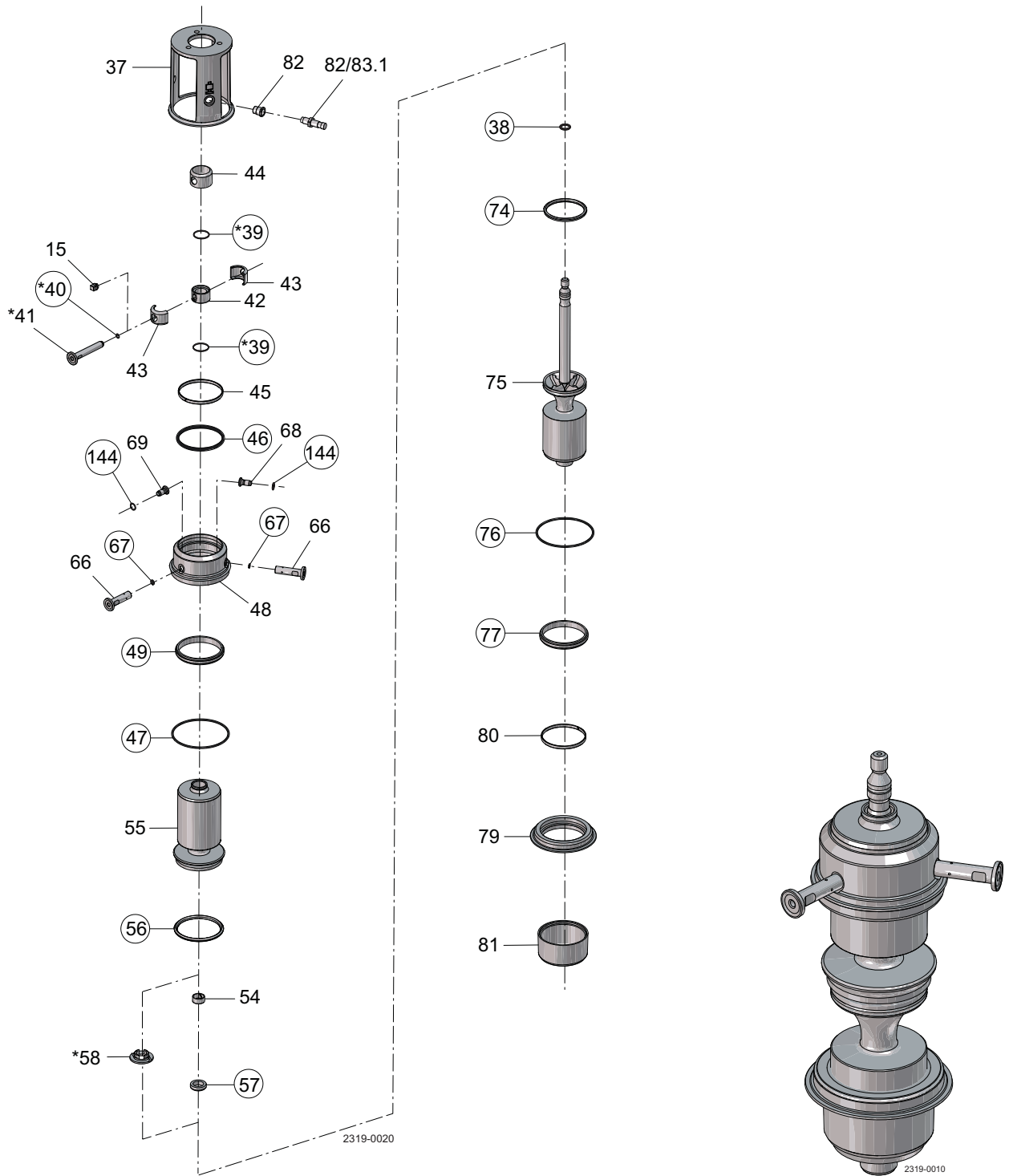

8 Parts list and service kits

For spare parts please refer to spare parts catalogue.

Parts list

Pos.	Qty	Denomination
15	1	Plug
37	1	Intermediate piece
38	1	O-ring
39	2	O-ring
40	1	O-ring
41	1	Flushing tube
42	1	Spindle liner
43	2	Clamp
44	1	Lock
45	1	Guide ring
46	1	O-ring
47	1	O-ring
48	1	Upper sealing element
49	1	Lip seal
52	1	O-ring
54	1	Guide ring
55	1	Upper plug
56	1	Seal ring
57	1	Lip seal
58	1	Spray nozzle
66	2	Flushing tube
67	2	O-ring
68	1	Drain
69	1	Nozzle
74	1	Seal ring
75	1	Lower plug
76	1	O-ring
77	1	Lip seal
79	1	Lower sealing element
80	1	Guide ring
81	1	Cover
82	1	Bolt for indication
83	1	Sensor for indication
83.1	1	Cable for sensor for indication
144	2	O-ring

Service kits

Denomination	1½"	2"	2½"	3"	4"	6"
	Seat ø53.3	Seat ø53.3	Seat ø81.3	Seat ø81.3	Seat ø100.3	Seat ø115.3
Service kit, EPDM	9611-92-8017	9611-92-8021	9611-92-8025	9611-92-8025	9611-92-8029	9611-92-8033
Service kit, NBR	9611-92-8018	9611-92-8022	9611-92-8026	9611-92-8026	9611-92-8030	9611-92-8034
Service kit, FPM	9611-92-8019	9611-92-8023	9611-92-8027	9611-92-8027	9611-92-8031	9611-92-8035
Service kit, HNBR	9611-92-8020	9611-92-8024	9611-92-8028	9611-92-8028	9611-92-8032	9611-92-8036

For mixed size housings, the service kit is determined by the smallest size connection on the valve.

One exception is any housing with 6" connections will always refer to the 6" service kits listed below:

Service kit, EPDM	9611-92-8137	9611-92-8141	9611-92-8145	9611-92-8145	9611-92-8149
Service kit, NBR	9611-92-8138	9611-92-8142	9611-92-8146	9611-92-8146	9611-92-8150
Service kit, FPM	9611-92-8139	9611-92-8143	9611-92-8147	9611-92-8147	9611-92-8151
Service kit, HNBR	9611-92-8140	9611-92-8144	9611-92-8148	9611-92-8148	9611-92-8152

8 Parts list and service kits

For spare parts please refer to spare parts catalogue.

8.5 Plug setup 5

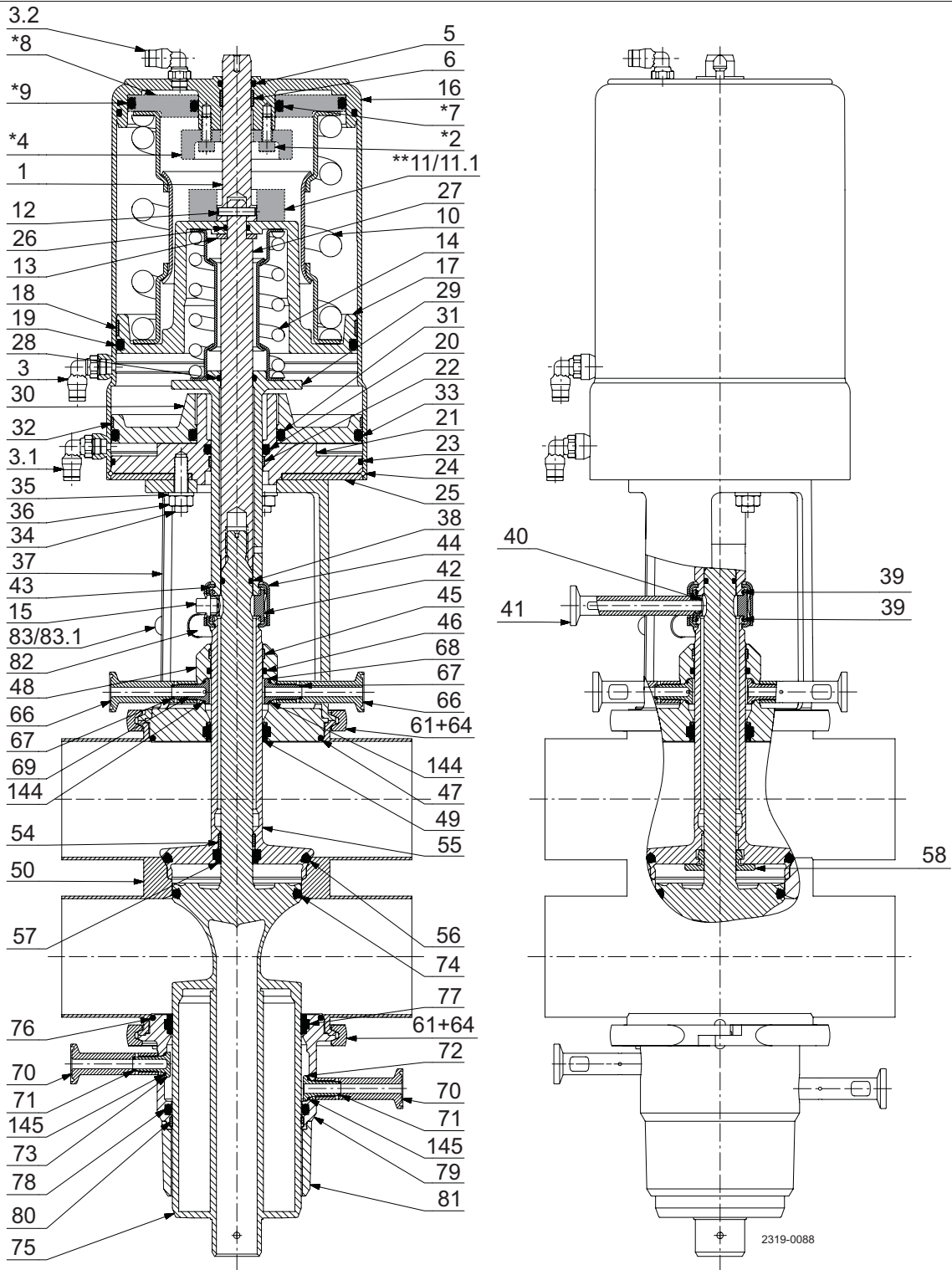

without SpiralClean in leakage chamber

with SpiralClean in leakage chamber

- = Parts not used in all actuators
- * = Not used in 1½" and 2"
- ** = Not used in 2½", 3", 4" and 6"

8 Parts list and service kits

For spare parts please refer to spare parts catalogue.

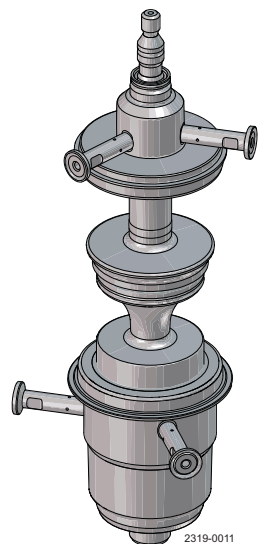
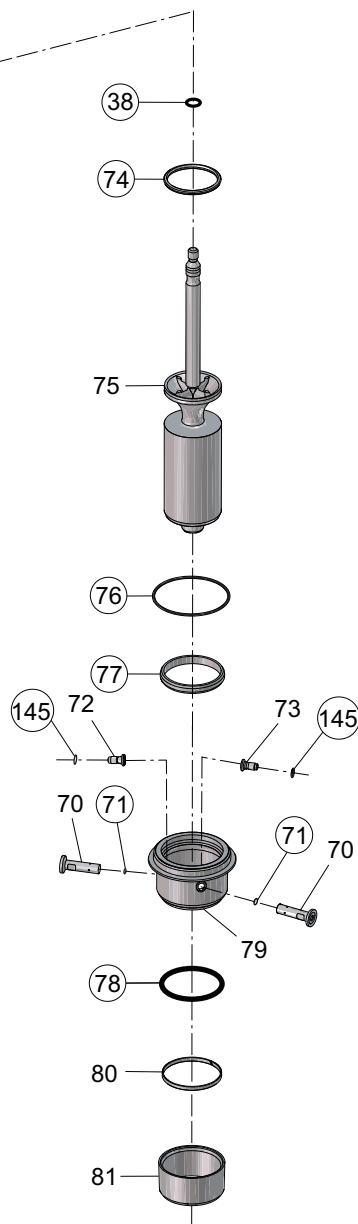
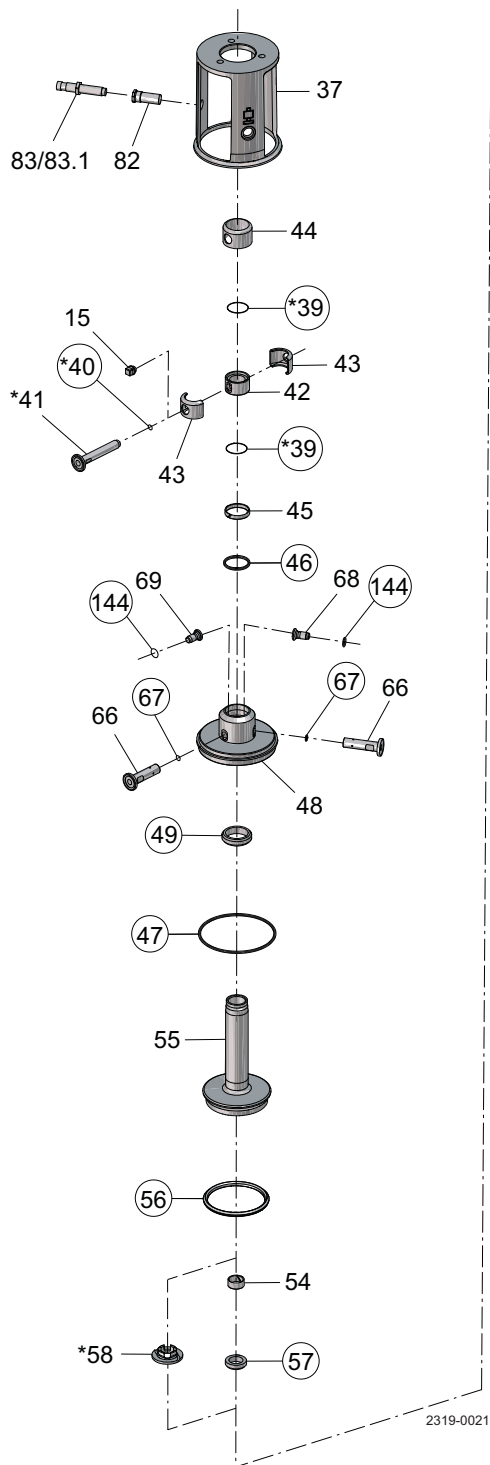

○ = wear parts

* = with SpiralClean in leakage chamber

8 Parts list and service kits

For spare parts please refer to spare parts catalogue.

Parts list

Pos.	Qty	Denomination
15	1	Plug
37	1	Intermediate piece
38	1	O-ring
39	2	O-ring
40	1	O-ring
41	1	Flushing tube
42	1	Spindle liner
43	2	Clamp
44	1	Lock
45	1	Guide ring
46	1	O-ring
47	1	O-ring
48	1	Upper sealing element
49	1	Lip seal
52	1	O-ring
54	1	Guide ring
55	1	Upper plug
56	1	Seal ring
57	1	Lip seal
58	1	Spray nozzle
66	2	Flushing tube
67	2	O-ring
68	1	Drain
69	1	Nozzle
70	2	Flushing tube
71	2	O-ring
72	1	Drain
73	1	Nozzle
74	1	Seal ring
75	1	Lower plug
76	1	O-ring
77	1	Lip seal
78	1	O-ring
79	1	Lower sealing element
80	1	Guide ring
81	1	Cover
82	1	Bolt for indication
83	1	Sensor for indication
83.1	1	Cable for sensor for indication
144	2	O-ring
145	2	O-ring

Service kits

Denomination	2" Seat ø53.3	2½" Seat ø81.3	3" Seat ø81.3	4" Seat ø100.3	6" Seat ø115.3
Service kit, EPDM	9611-92-8037	9611-92-8041	9611-92-8041	9611-92-8045	9611-92-8049
Service kit, NBR	9611-92-8038	9611-92-8042	9611-92-8042	9611-92-8046	9611-92-8050
Service kit, FPM	9611-92-8039	9611-92-8043	9611-92-8043	9611-92-8047	9611-92-8051
Service kit, HNBR	9611-92-8040	9611-92-8044	9611-92-8044	9611-92-8048	9611-92-8052

For mixed size housings, the service kit is determined by the smallest size connection on the valve.

One exception is any housing with 6" connections will always refer to the 6" service kits listed below:

Service kit, EPDM	9611-92-8153	9611-92-8157	9611-92-8157	9611-92-8161
Service kit, NBR	9611-92-8154	9611-92-8158	9611-92-8158	9611-92-8162
Service kit, FPM	9611-92-8155	9611-92-8159	9611-92-8159	9611-92-8163
Service kit, HNBR	9611-92-8156	9611-92-8160	9611-92-8160	9611-92-8164

8 Parts list and service kits

For spare parts please refer to spare parts catalogue.

8.6 Plug setup 6

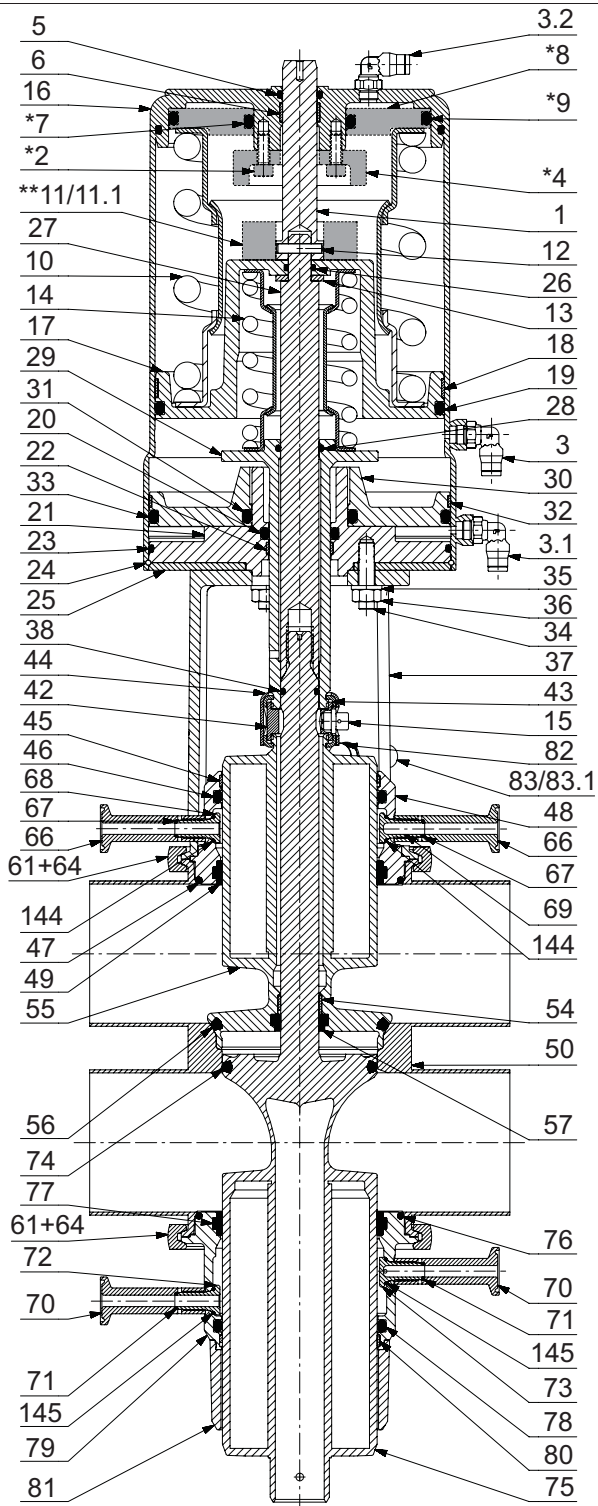

without SpiralClean in leakage chamber

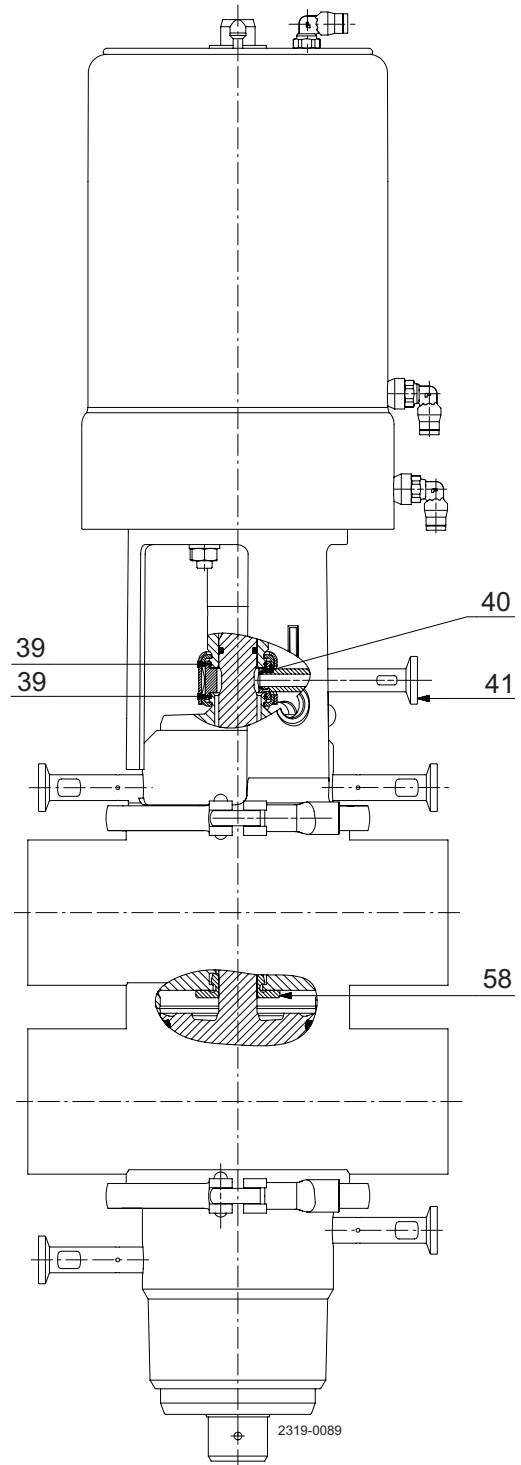

with SpiralClean in leakage chamber

- = Parts not used in all actuators
- * = Not used in 1½" and 2"
- ** = Not used in 2½", 3", 4" and 6"

8 Parts list and service kits

For spare parts please refer to spare parts catalogue.

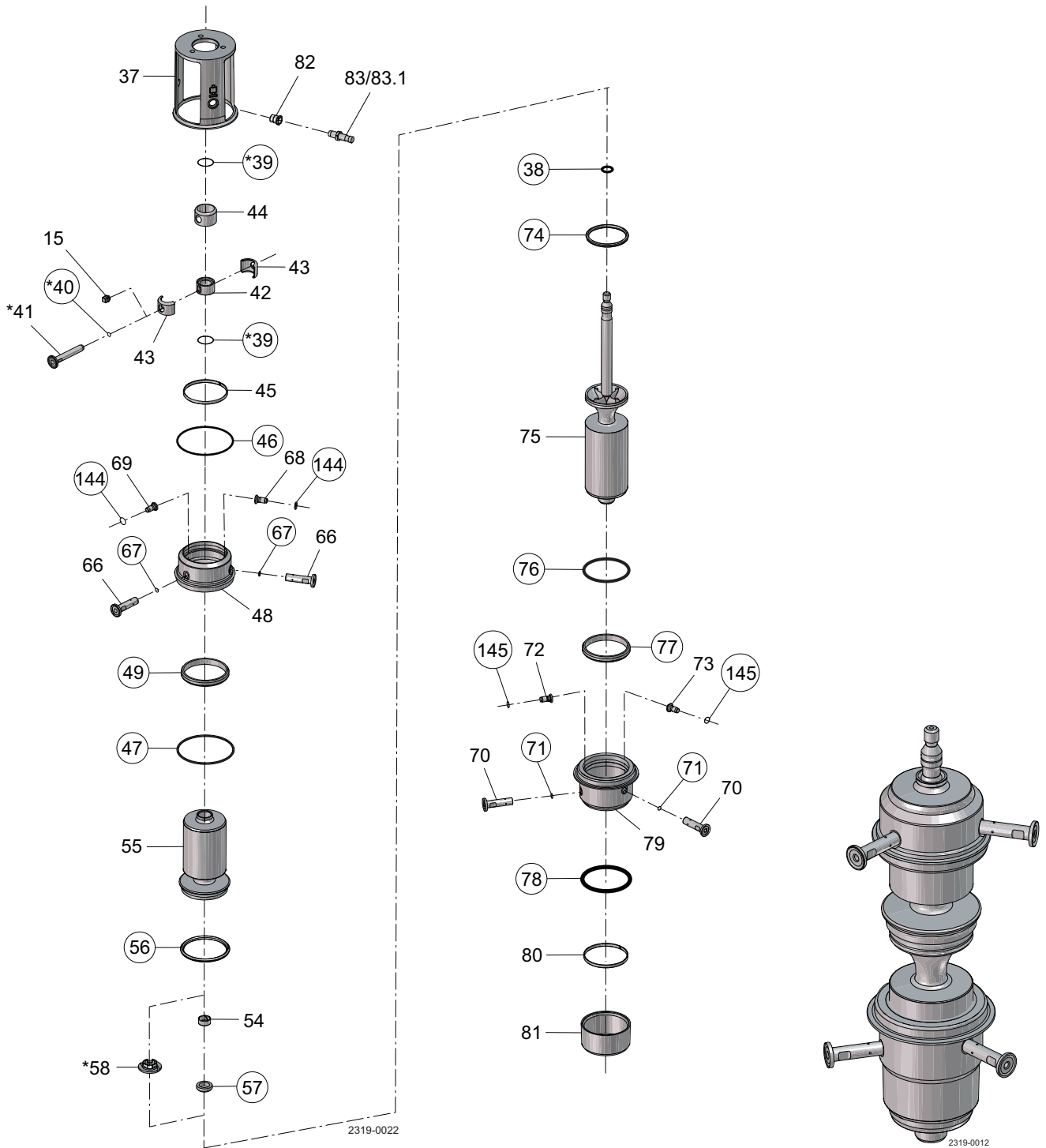

8 Parts list and service kits

For spare parts please refer to spare parts catalogue.

Parts list

Pos.	Qty	Denomination
15	1	Plug
37	1	Intermediate piece
38	1	O-ring
39	2	O-ring
40	1	O-ring
41	1	Flushing tube
42	1	Spindle liner
43	2	Clamp
44	1	Lock
45	1	Guide ring
46	1	O-ring
47	1	O-ring
48	1	Upper sealing element
49	1	Lip seal
52	1	O-ring
54	1	Guide ring
55	1	Upper plug
56	1	Seal ring
57	1	Lip seal
58	1	Spray nozzle
66	2	Flushing tube
67	2	O-ring
68	1	Drain
69	1	Nozzle
70	2	Flushing tube
71	2	O-ring
72	1	Drain
73	1	Nozzle
74	1	Seal ring
75	1	Lower plug
76	1	O-ring
77	1	Lip seal
78	1	O-ring
79	1	Lower sealing element
80	1	Guide ring
81	1	Cover
82	1	Bolt for indication
83	1	Sensor for indication
83.1	1	Cable for sensor for indication
144	2	O-ring
145	2	O-ring

Service kits

Denomination	1½" Seat ø53.3	2" Seat ø53.3	2½" Seat ø81.3	3" Seat ø81.3	4" Seat ø100.3	6" Seat ø115.3
Service kit, EPDM	9611-92-8053	9611-92-8057	9611-92-8061	9611-92-8061	9611-92-8065	9611-92-8069
Service kit, NBR	9611-92-8054	9611-92-8058	9611-92-8062	9611-92-8062	9611-92-8066	9611-92-8070
Service kit, FPM	9611-92-8055	9611-92-8059	9611-92-8063	9611-92-8063	9611-92-8067	9611-92-8071
Service kit, HNBR	9611-92-8056	9611-92-8060	9611-92-8064	9611-92-8064	9611-92-8068	9611-92-8072

For mixed size housings, the service kit is determined by the smallest size connection on the valve.

One exception is any housing with 6" connections will always refer to the 6" service kits listed below:

Service kit, EPDM	9611-92-8165	9611-92-8169	9611-92-8173	9611-92-8173	9611-92-8177
Service kit, NBR	9611-92-8166	9611-92-8170	9611-92-8174	9611-92-8174	9611-92-8178
Service kit, FPM	9611-92-8167	9611-92-8171	9611-92-8175	9611-92-8175	9611-92-8179
Service kit, HNBR	9611-92-8168	9611-92-8172	9611-92-8176	9611-92-8176	9611-92-8180

8 Parts list and service kits

For spare parts please refer to spare parts catalogue.

8.7 Plug setup 11

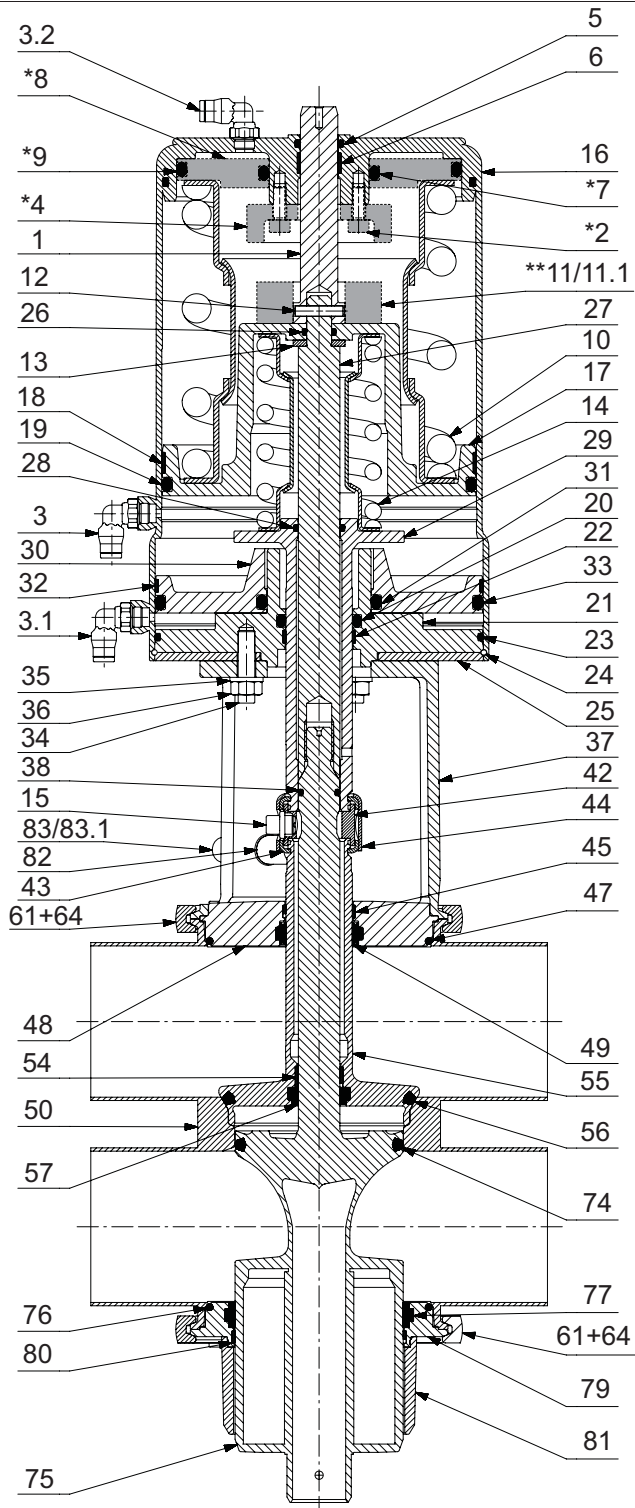

without SpiralClean in leakage chamber

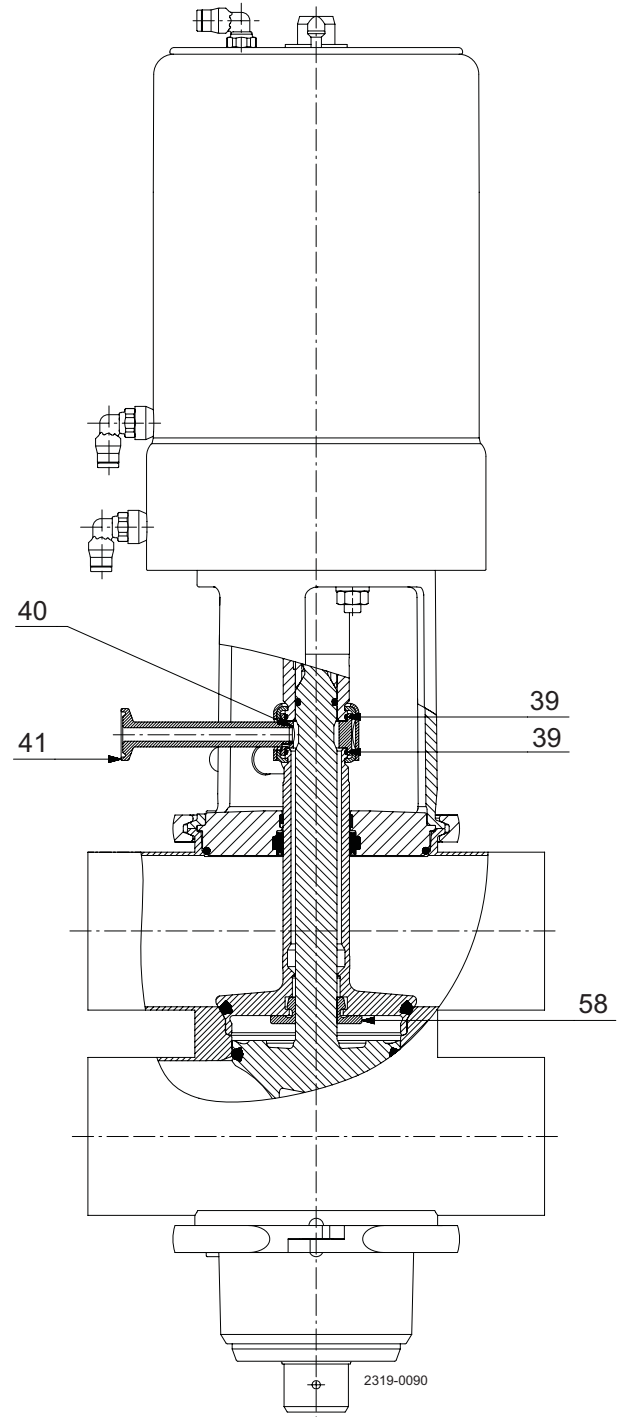

with SpiralClean in leakage chamber

- = Parts not used in all actuators
- * = Not used in 1½" and 2"
- ** = Not used in 2½", 3", 4" and 6"

8 Parts list and service kits

For spare parts please refer to spare parts catalogue.

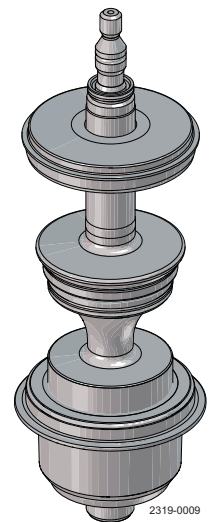
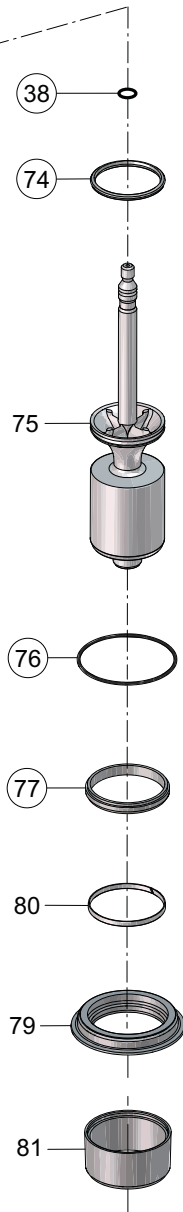
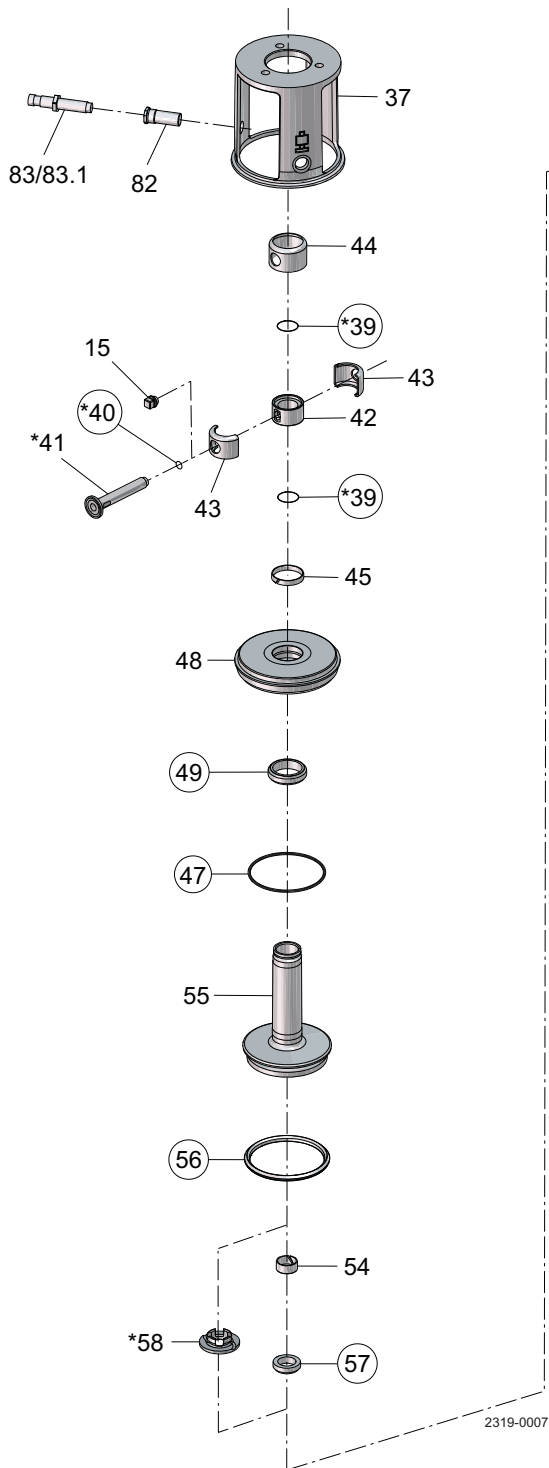

○ = wear parts

* = with SpiralClean in leakage chamber

8 Parts list and service kits

For spare parts please refer to spare parts catalogue.

Parts list

Pos.	Qty	Denomination
15	1	Plug
37	1	Intermediate piece
38	1	O-ring
39	2	O-ring
40	1	O-ring
41	1	Flushing tube
42	1	Spindle liner
43	2	Clamp
44	1	Lock
45	1	Guide ring
47	1	O-ring
48	1	Upper sealing element
49	1	Lip seal
52	1	O-ring
54	1	Guide ring
55	1	Upper plug
56	1	Seal ring
57	1	Lip seal
58	1	Spray nozzle
74	1	Seal ring
75	1	Lower plug
76	1	O-ring
77	1	Lip seal
79	1	Lower sealing element
80	1	Guide ring
81	1	Cover
82	1	Bolt for indication
83	1	Sensor for indication
83.1	1	Cable for sensor for indication

Service kits

Denomination	2" Seat ø53.3	2½" Seat ø81.3	3" Seat ø81.3	4" Seat ø100.3	6" Seat ø115.3
Service kit, EPDM	9611-92-8073	9611-92-8077	9611-92-8077	9611-92-8081	9611-92-8085
Service kit, NBR	9611-92-8074	9611-92-8078	9611-92-8078	9611-92-8082	9611-92-8086
Service kit, FPM	9611-92-8075	9611-92-8079	9611-92-8079	9611-92-8083	9611-92-8087
Service kit, HNBR	9611-92-8076	9611-92-8080	9611-92-8080	9611-92-8084	9611-92-8088

For mixed size housings, the service kit is determined by the smallest size connection on the valve.

One exception is any housing with 6" connections will always refer to the 6" service kits listed below:

Service kit, EPDM	9611-92-8181	9611-92-8185	9611-92-8185	9611-92-8189
Service kit, NBR	9611-92-8182	9611-92-8186	9611-92-8186	9611-92-8190
Service kit, FPM	9611-92-8183	9611-92-8187	9611-92-8187	9611-92-8191
Service kit, HNBR	9611-92-8184	9611-92-8188	9611-92-8188	9611-92-8192

8 Parts list and service kits

For spare parts please refer to spare parts catalogue.

8.8 Plug setup 12

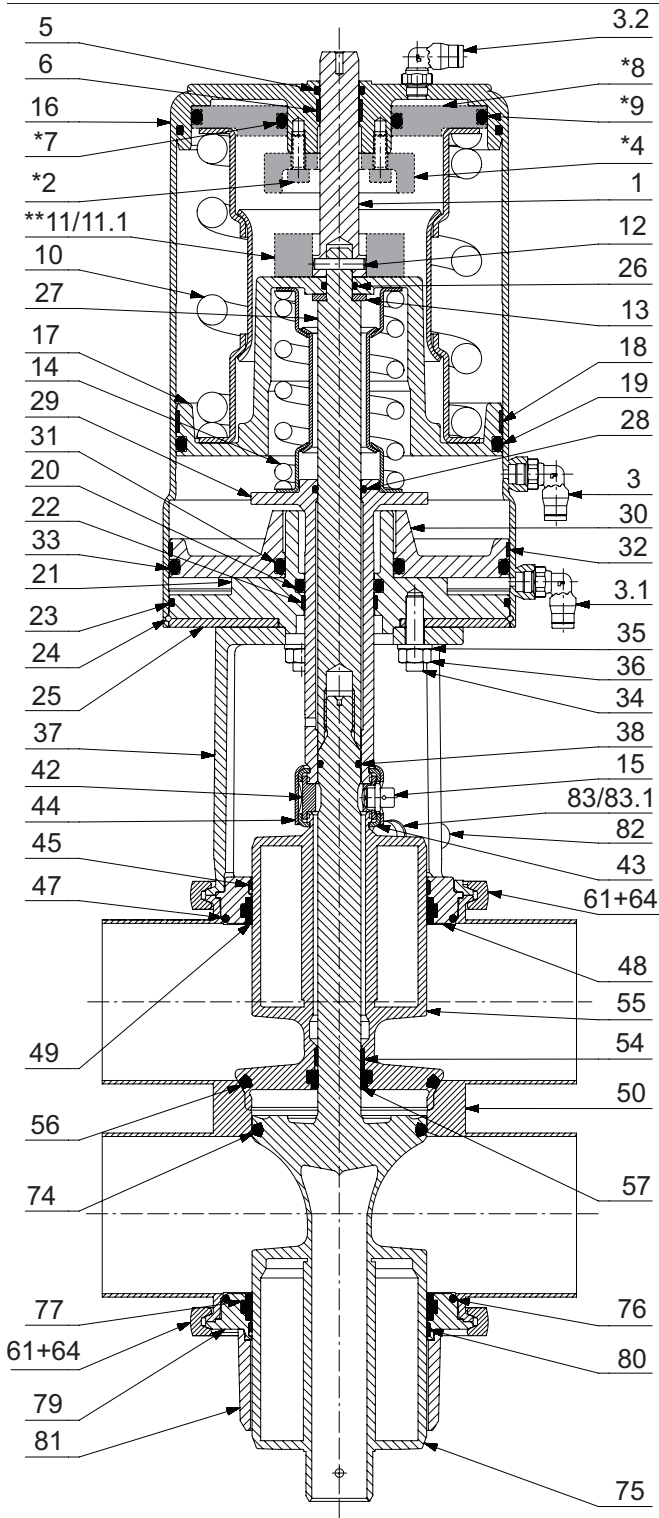

without SpiralClean in leakage chamber

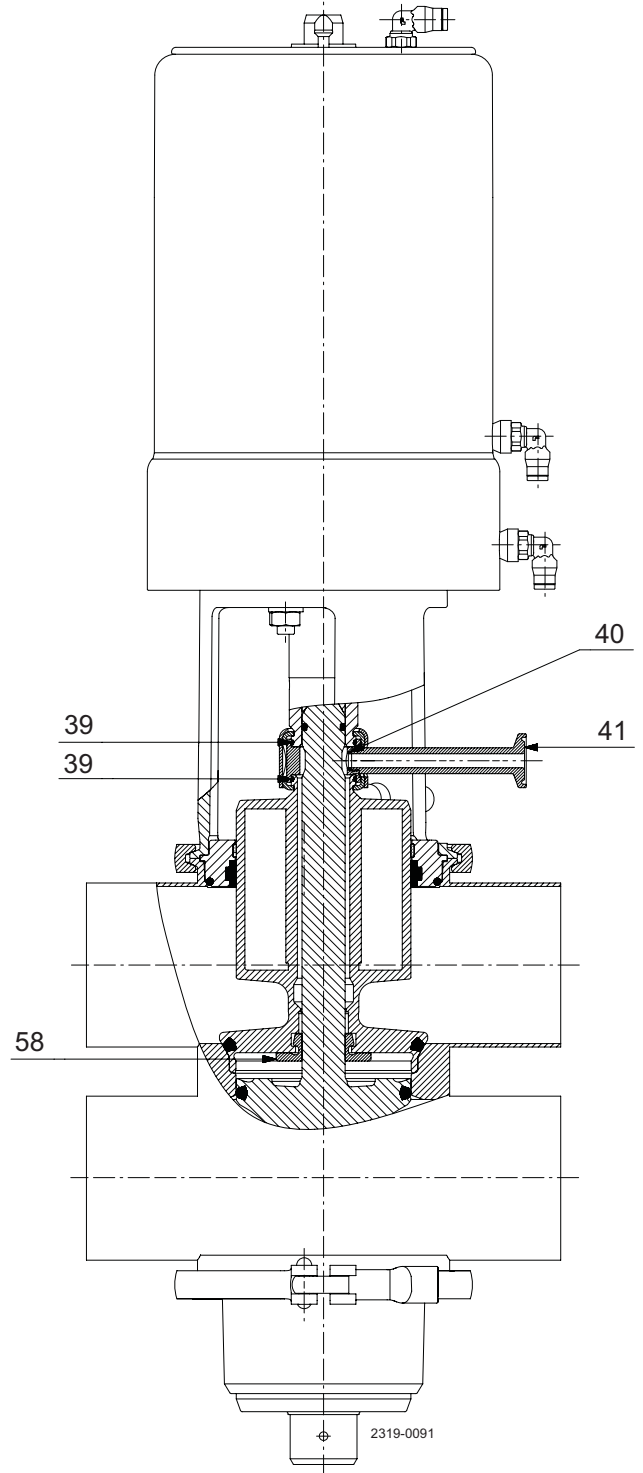

with SpiralClean in leakage chamber

- = Parts not used in all actuators
- * = Not used in 1½" and 2"
- ** = Not used in 2½", 3", 4" and 6"

8 Parts list and service kits

For spare parts please refer to spare parts catalogue.

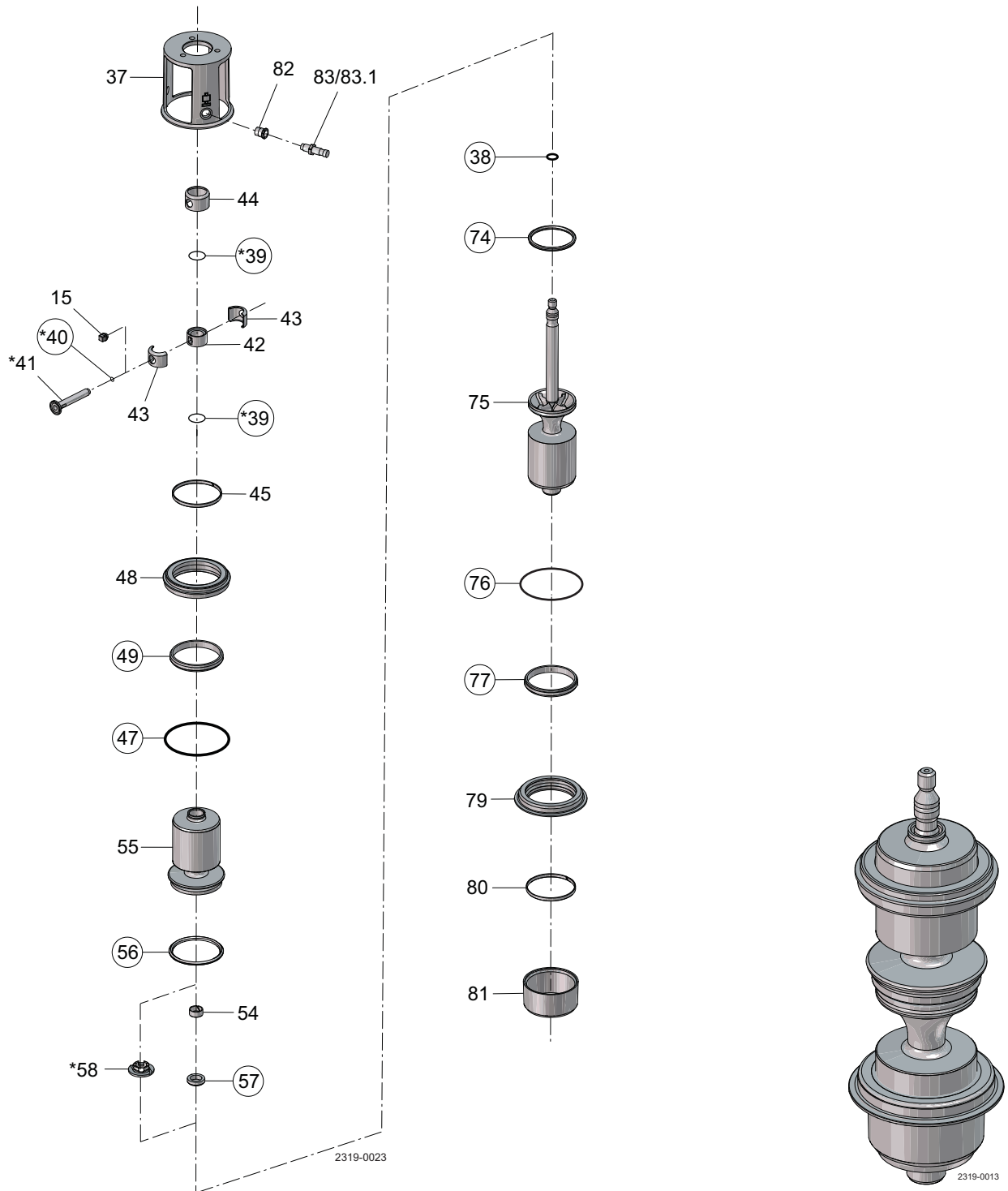

8 Parts list and service kits

For spare parts please refer to spare parts catalogue.

Parts list

Pos.	Qty	Denomination
15	1	Plug
37	1	Intermediate piece
38	1	O-ring
39	2	O-ring
40	1	O-ring
41	1	Flushing tube
42	1	Spindle liner
43	2	Clamp
44	1	Lock
45	1	Guide ring
47	1	O-ring
48	1	Upper sealing element
49	1	Lip seal
52	1	O-ring
54	1	Guide ring
55	1	Upper plug
56	1	Seal ring
57	1	Lip seal
58	1	Spray nozzle
74	1	Seal ring
75	1	Lower plug
76	1	O-ring
77	1	Lip seal
79	1	Lower sealing element
80	1	Guide ring
81	1	Cover
82	1	Bolt for indication
83	1	Sensor for indication
83.1	1	Cable for sensor for indication

Service kits

Denomination	1½" Seat ø53.3	2" Seat ø53.3	2½" Seat ø81.3	3" Seat ø81.3	4" Seat ø100.3	6" Seat ø115.3
Service kit, EPDM	9611-92-8089	9611-92-8093	9611-92-8097	9611-92-8097	9611-92-8101	9611-92-8105
Service kit, NBR	9611-92-8090	9611-92-8094	9611-92-8098	9611-92-8098	9611-92-8102	9611-92-8106
Service kit, FPM	9611-92-8091	9611-92-8095	9611-92-8099	9611-92-8099	9611-92-8103	9611-92-8107
Service kit, HNBR	9611-92-8092	9611-92-8096	9611-92-8100	9611-92-8100	9611-92-8104	9611-92-8108

For mixed size housings, the service kit is determined by the smallest size connection on the valve.

One exception is any housing with 6" connections will always refer to the 6" service kits listed below:

Service kit, EPDM	9611-92-8193	9611-92-8197	9611-92-8201	9611-92-8201	9611-92-8205
Service kit, NBR	9611-92-8194	9611-92-8198	9611-92-8202	9611-92-8202	9611-92-8206
Service kit, FPM	9611-92-8195	9611-92-8199	9611-92-8203	9611-92-8203	9611-92-8207
Service kit, HNBR	9611-92-8196	9611-92-8200	9611-92-8204	9611-92-8204	9611-92-8208

8 Parts list and service kits

For spare parts please refer to spare parts catalogue.

8.9 Plug setup 13

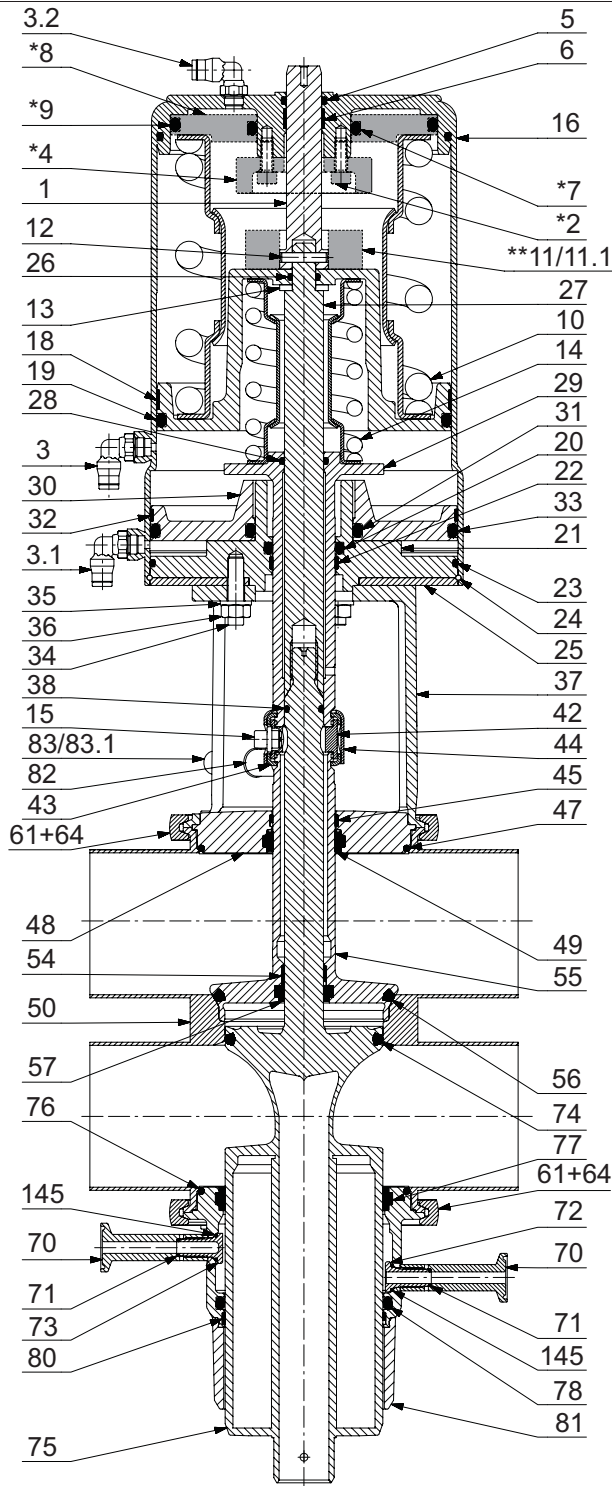

without SpiralClean in leakage chamber

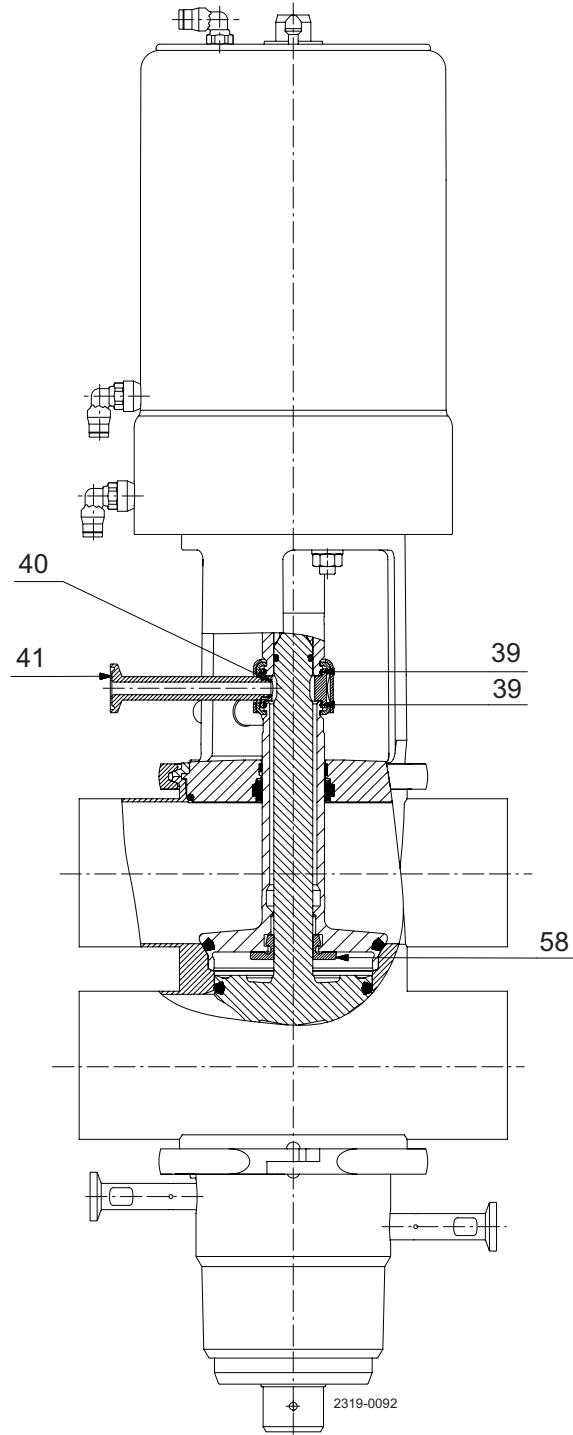

with SpiralClean in leakage chamber

■ = Parts not used in all actuators

* = Not used in 1½" and 2"

** = Not used in 2½", 3", 4" and 6"

8 Parts list and service kits

For spare parts please refer to spare parts catalogue.

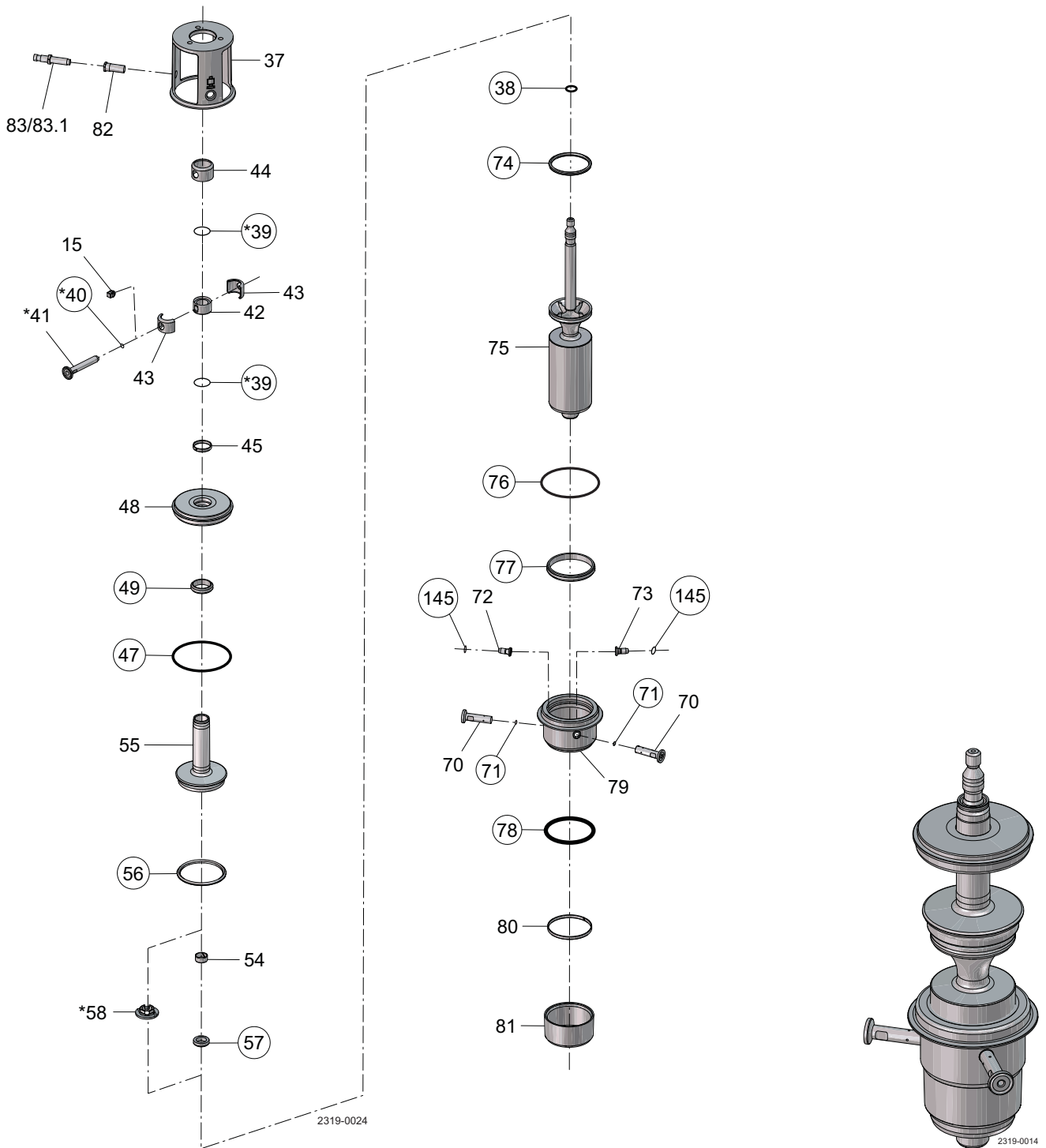

○ = wear parts

* = with SpiralClean in leakage chamber

2319-0014

8 Parts list and service kits

For spare parts please refer to spare parts catalogue.

Parts list

Pos.	Qty	Denomination
15	1	Plug
37	1	Intermediate piece
38	1	O-ring
39	2	O-ring
40	1	O-ring
41	1	Flushing tube
42	1	Spindle liner
43	2	Clamp
44	1	Lock
45	1	Guide ring
47	1	O-ring
48	1	Upper sealing element
49	1	Lip seal
52	1	O-ring
54	1	Guide ring
55	1	Upper plug
56	1	Seal ring
57	1	Lip seal
58	1	Spray nozzle
70	2	Flushing tube
71	2	O-ring
72	1	Drain
73	1	Nozzle
74	1	Seal ring
75	1	Lower plug
76	1	O-ring
77	1	Lip seal
78	1	O-ring
79	1	Lower sealing element
80	1	Guide ring
81	1	Cover
82	1	Bolt for indication
83	1	Sensor for indication
83.1	1	Cable for sensor for indication
145	2	O-ring

Service kits

Denomination	2"	2½"	3"	4"	6"
	Seat ø53.3	Seat ø81.3	Seat ø81.3	Seat ø100.3	Seat ø115.3
Service kit, EPDM	9611-92-8109	9611-92-8113	9611-92-8113	9611-92-8117	9611-92-8121
Service kit, NBR	9611-92-8110	9611-92-8114	9611-92-8114	9611-92-8118	9611-92-8122
Service kit, FPM	9611-92-8111	9611-92-8115	9611-92-8115	9611-92-8119	9611-92-8123
Service kit, HNBR	9611-92-8112	9611-92-8116	9611-92-8116	9611-92-8120	9611-92-8124

For mixed size housings, the service kit is determined by the smallest size connection on the valve.

One exception is any housing with 6" connections will always refer to the 6" service kits listed below:

Service kit, EPDM	9611-92-8209	9611-92-8213	9611-92-8213	9611-92-8217
Service kit, NBR	9611-92-8210	9611-92-8214	9611-92-8214	9611-92-8218
Service kit, FPM	9611-92-8211	9611-92-8215	9611-92-8215	9611-92-8219
Service kit, HNBR	9611-92-8212	9611-92-8216	9611-92-8216	9611-92-8220

8 Parts list and service kits

For spare parts please refer to spare parts catalogue.

8.10 Plug setup 14

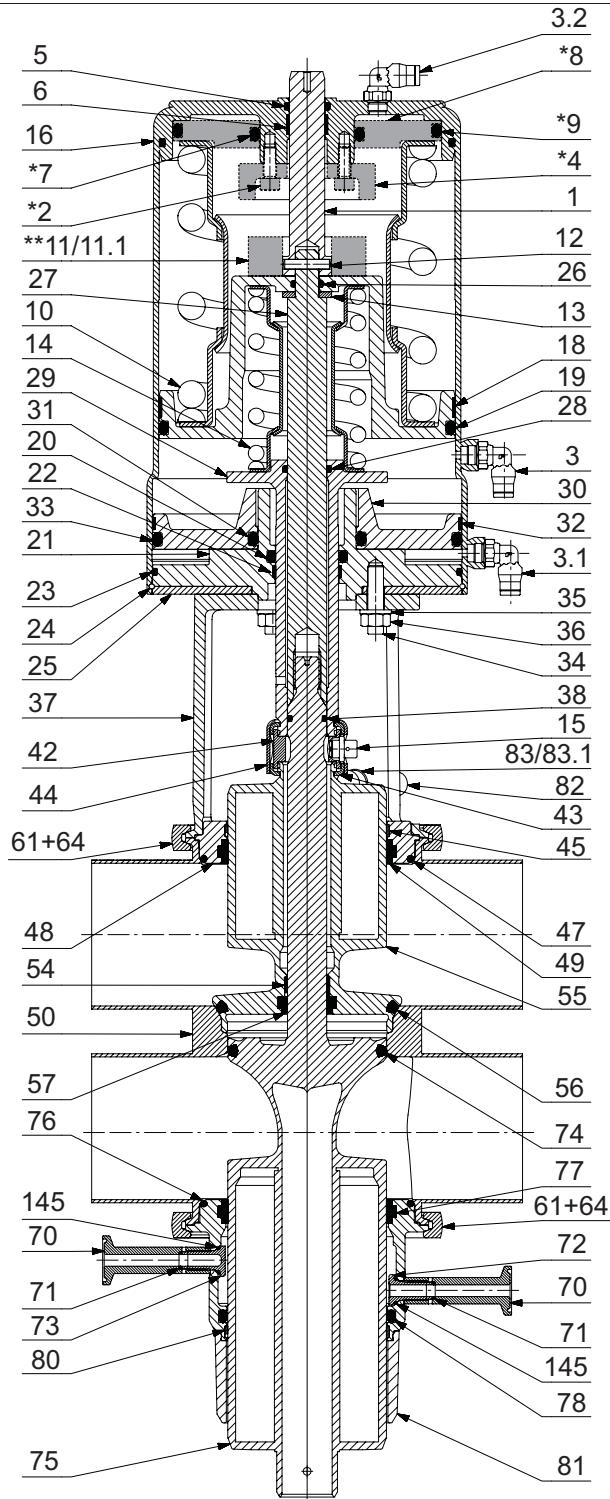

without SpiralClean in leakage chamber

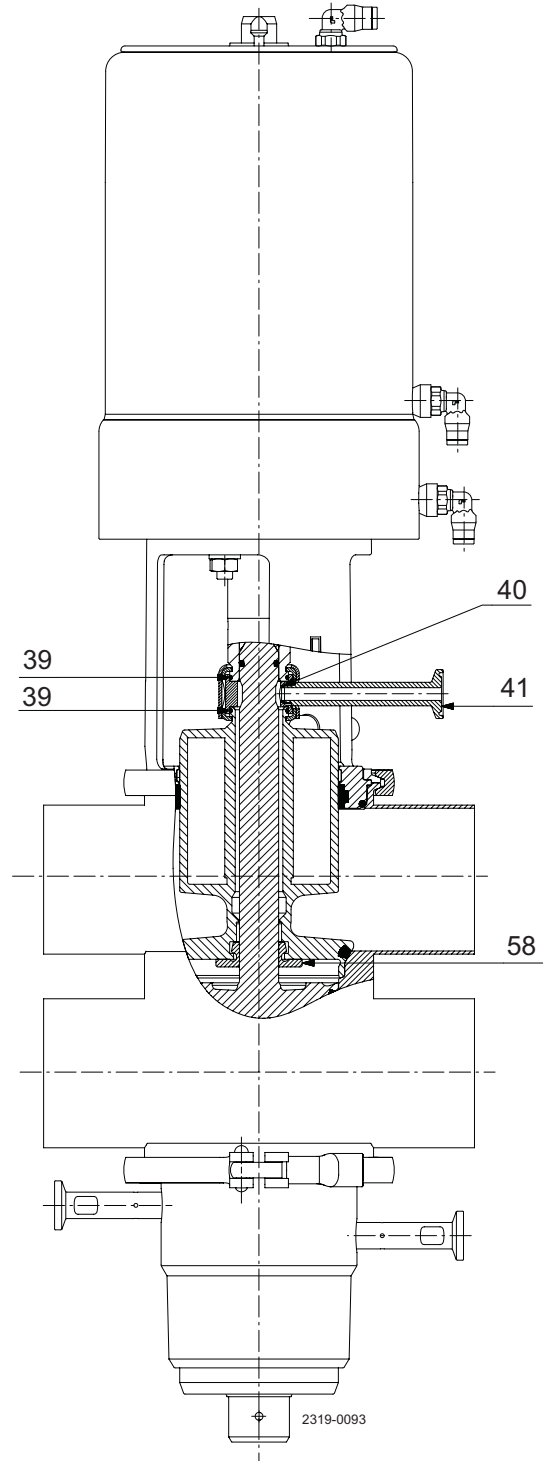

with SpiralClean in leakage chamber

- = Parts not used in all actuators
- * = Not used in 1½" and 2"
- ** = Not used in 2½", 3", 4" and 6"

8 Parts list and service kits

For spare parts please refer to spare parts catalogue.

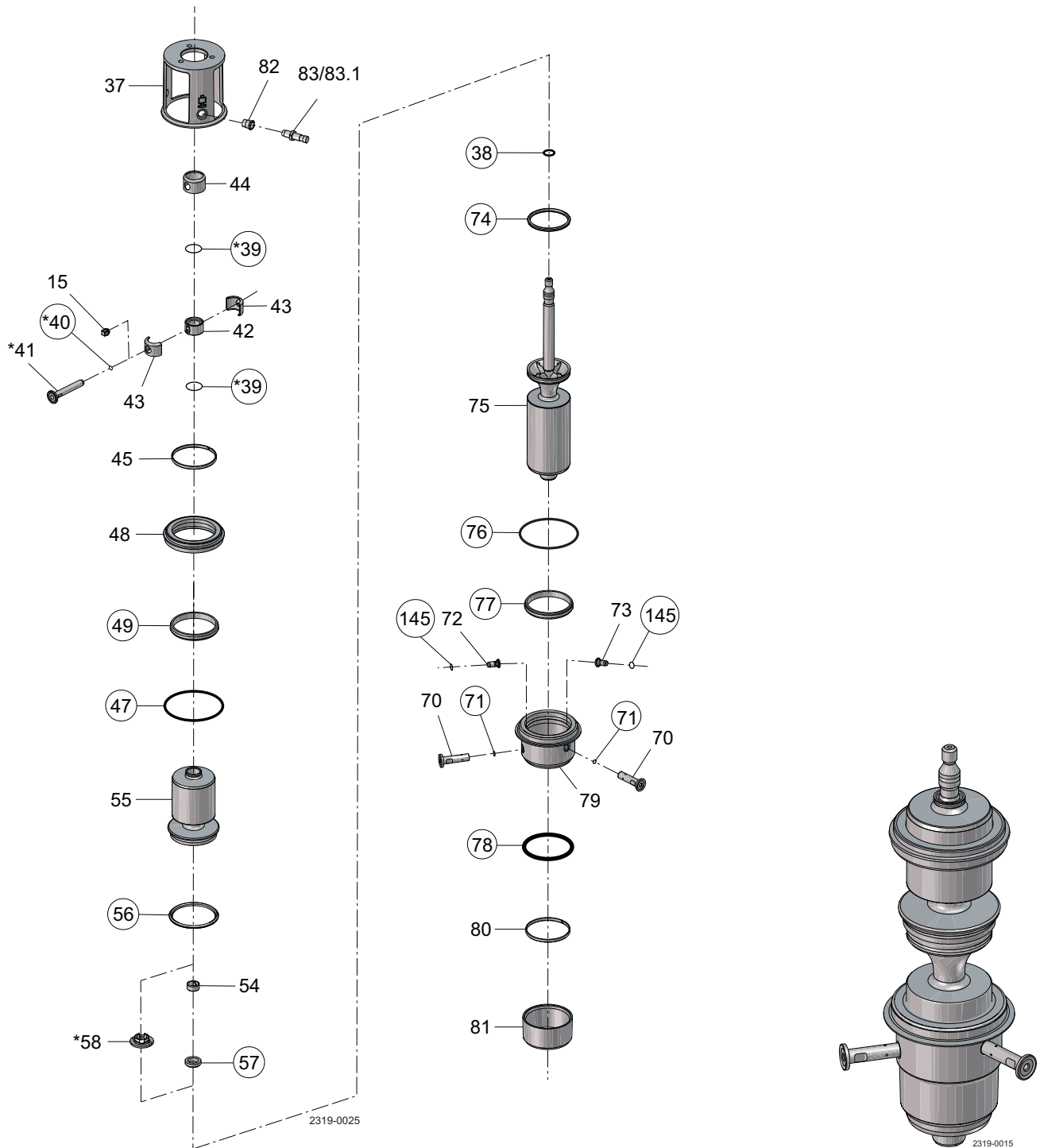

○ = wear parts

* = with SpiralClean in leakage chamber

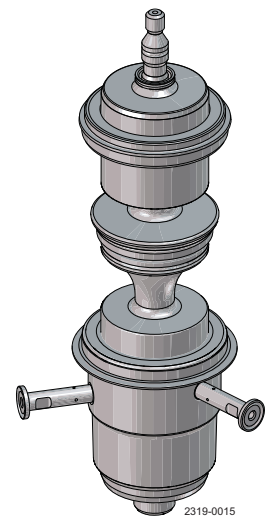

8 Parts list and service kits

For spare parts please refer to spare parts catalogue.

Parts list

Pos.	Qty	Denomination
15	1	Plug
37	1	Intermediate piece
38	1	O-ring
39	2	O-ring
40	1	O-ring
41	1	Flushing tube
42	1	Spindle liner
43	2	Clamp
44	1	Lock
45	1	Guide ring
47	1	O-ring
48	1	Upper sealing element
49	1	Lip seal
52	1	O-ring
54	1	Guide ring
55	1	Upper plug
56	1	Seal ring
57	1	Lip seal
58	1	Spray nozzle
70	2	Flushing tube
71	2	O-ring
72	1	Drain
73	1	Nozzle
74	1	Seal ring
75	1	Lower plug
76	1	O-ring
77	1	Lip seal
78	1	O-ring
79	1	Lower sealing element
80	1	Guide ring
81	1	Cover
82	1	Bolt for indication
83	1	Sensor for indication
83.1	1	Cable for sensor for indication
145	2	O-ring

Service kits

Denomination	1½"	2"	2½"	3"	4"	6"
	Seat ø53.3	Seat ø53.3	Seat ø81.3	Seat ø81.3	Seat ø100.3	Seat ø115.3
Service kit, EPDM	9611-92-8017	9611-92-8021	9611-92-8025	9611-92-8025	9611-92-8029	9611-92-8033
Service kit, NBR	9611-92-8018	9611-92-8022	9611-92-8026	9611-92-8026	9611-92-8030	9611-92-8034
Service kit, FPM	9611-92-8019	9611-92-8023	9611-92-8027	9611-92-8027	9611-92-8031	9611-92-8035
Service kit, HNBR	9611-92-8020	9611-92-8024	9611-92-8028	9611-92-8028	9611-92-8032	9611-92-8036

For mixed size housings, the service kit is determined by the smallest size connection on the valve.

One exception is any housing with 6" connections will always refer to the 6" service kits listed below:

Service kit, EPDM	9611-92-8137	9611-92-8141	9611-92-8145	9611-92-8145	9611-92-8149
Service kit, NBR	9611-92-8138	9611-92-8142	9611-92-8146	9611-92-8146	9611-92-8150
Service kit, FPM	9611-92-8139	9611-92-8143	9611-92-8147	9611-92-8147	9611-92-8151
Service kit, HNBR	9611-92-8140	9611-92-8144	9611-92-8148	9611-92-8148	9611-92-8152

8 Parts list and service kits

For spare parts please refer to spare parts catalogue.

8.11 Plug setup 17

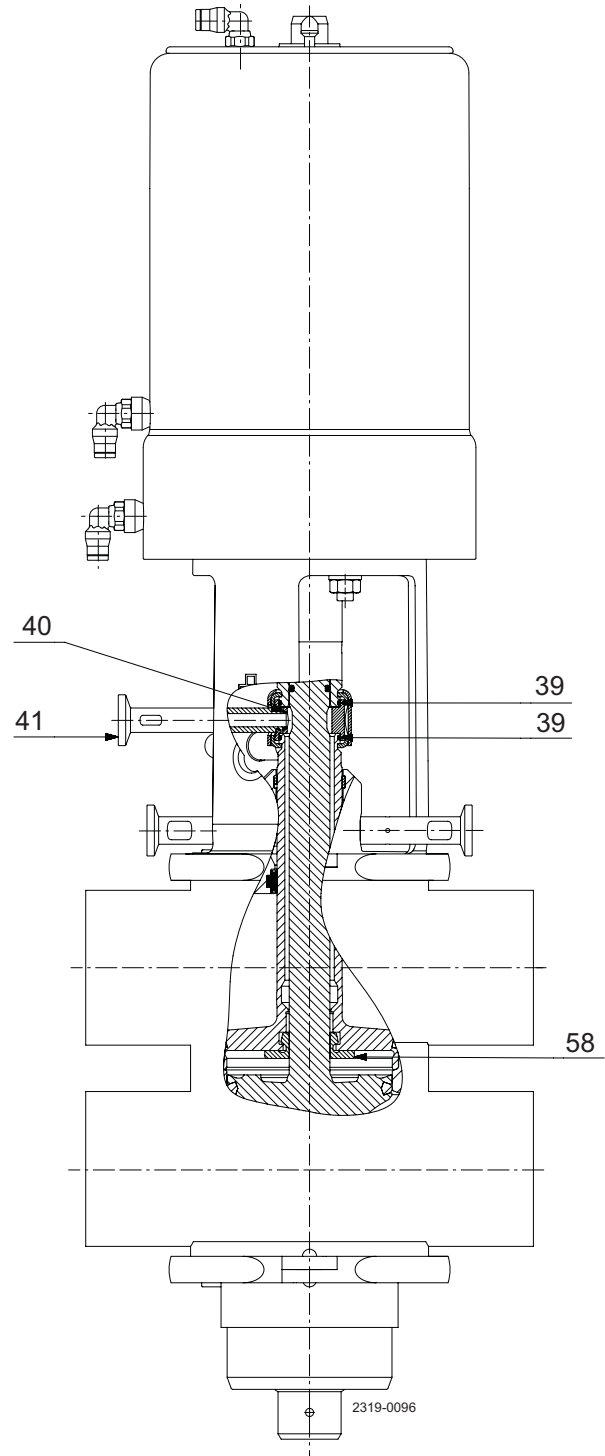
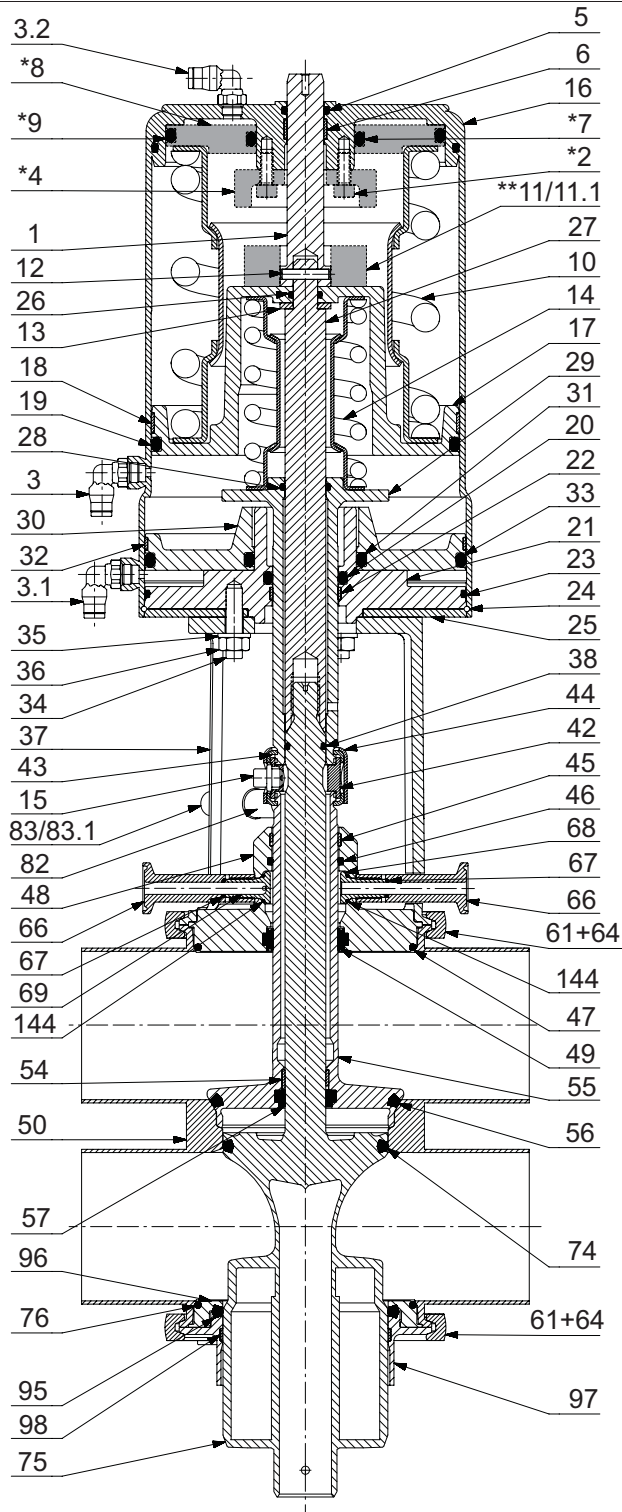

8 Parts list and service kits

For spare parts please refer to spare parts catalogue.

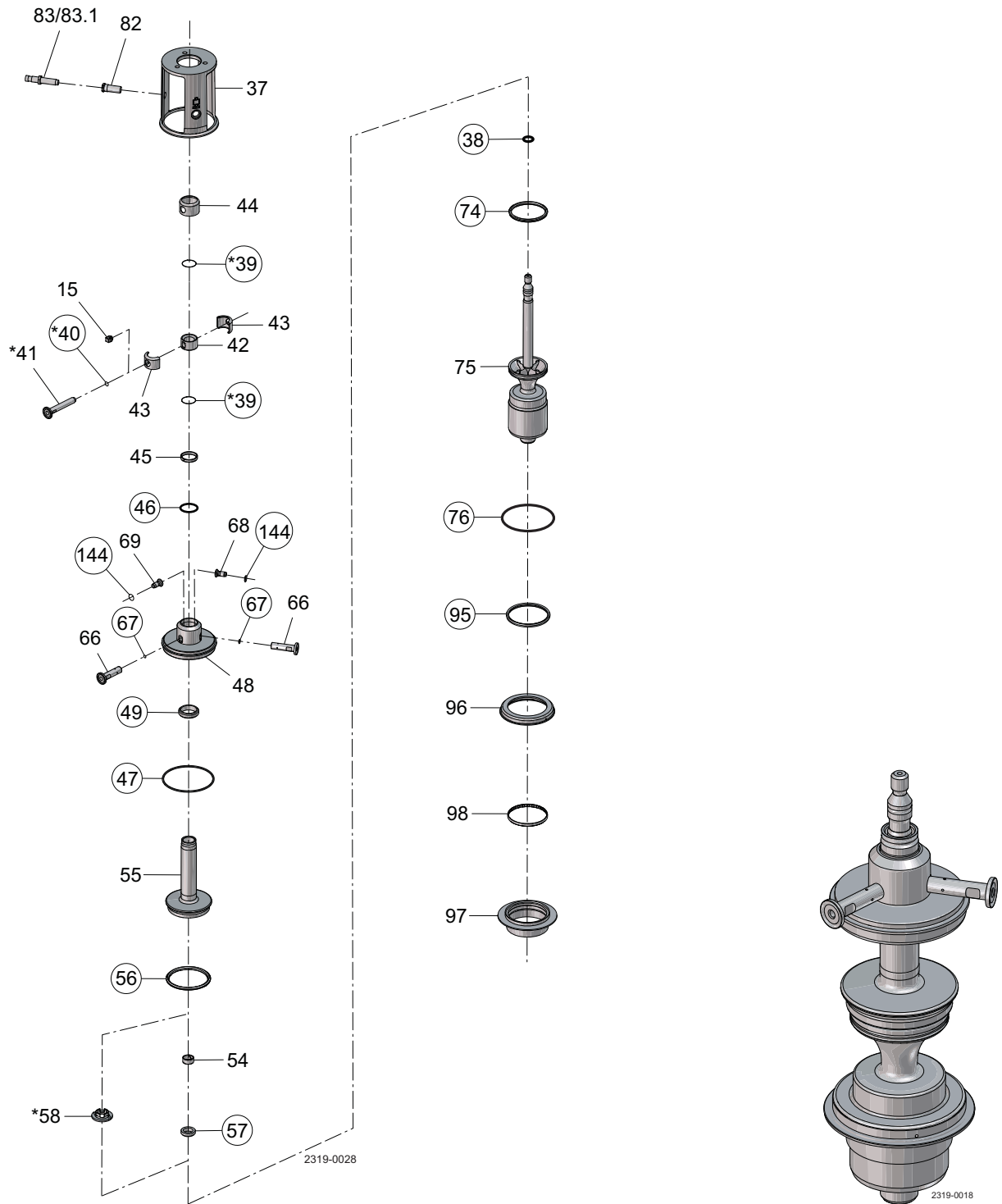

8 Parts list and service kits

For spare parts please refer to spare parts catalogue.

Parts list

Pos.	Qty	Denomination
15	1	Plug
37	1	Intermediate piece
38	1	O-ring
39	2	O-ring
40	1	O-ring
41	1	Flushing tube
42	1	Spindle liner
43	2	Clamp
44	1	Lock
45	1	Guide ring
46	1	O-ring
47	1	O-ring
48	1	Upper sealing element
49	1	Lip seal
52	1	O-ring
54	1	Guide ring
55	1	Upper plug
56	1	Seal ring
57	1	Lip seal
58	1	Spray nozzle
66	2	Flushing tube
67	2	O-ring
68	1	Drain
69	1	Nozzle
74	1	Seal ring
75	1	Lower plug
76	1	O-ring
82	1	Bolt for indication
83	1	Sensor for indication
83.1	1	Cable for sensor for indication
95	1	Special lip seal
96	1	Lower sealing element
97	1	Lower sealing element
98	1	Guide ring, Turcite
144	2	O-ring

Service kits

Denomination	2" Seat ø53.3	2½" Seat ø81.3	3" Seat ø81.3	4" Seat ø100.3	6" Seat ø115.3
Service kit, EPDM	9611-92-8221	9611-92-8225	9611-92-8225	9611-92-8229	9611-92-8233
Service kit, NBR	9611-92-8222	9611-92-8226	9611-92-8226	9611-92-8230	9611-92-8234
Service kit, FPM	9611-92-8223	9611-92-8227	9611-92-8227	9611-92-8231	9611-92-8235
Service kit, HNBR	9611-92-8224	9611-92-8228	9611-92-8228	9611-92-8232	9611-92-8236

For mixed size housings, the service kit is determined by the smallest size connection on the valve.

One exception is any housing with 6" connections will always refer to the 6" service kits listed below:

Service kit, EPDM	9611-92-8293	9611-92-8297	9611-92-8297	9611-92-8301
Service kit, NBR	9611-92-8294	9611-92-8298	9611-92-8298	9611-92-8302
Service kit, FPM	9611-92-8295	9611-92-8299	9611-92-8299	9611-92-8303
Service kit, HNBR	9611-92-8296	9611-92-8300	9611-92-8300	9611-92-8304

8 Parts list and service kits

For spare parts please refer to spare parts catalogue.

8.12 Plug setup 18

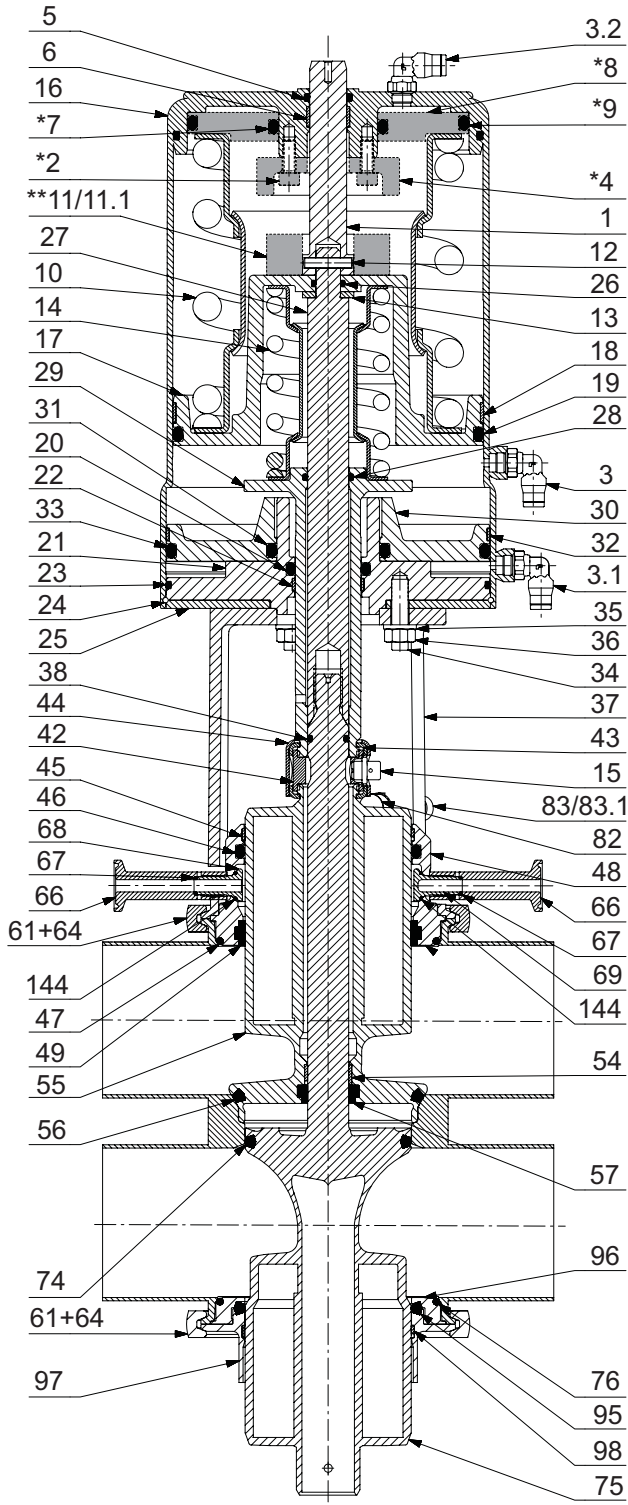

without SpiralClean in leakage chamber

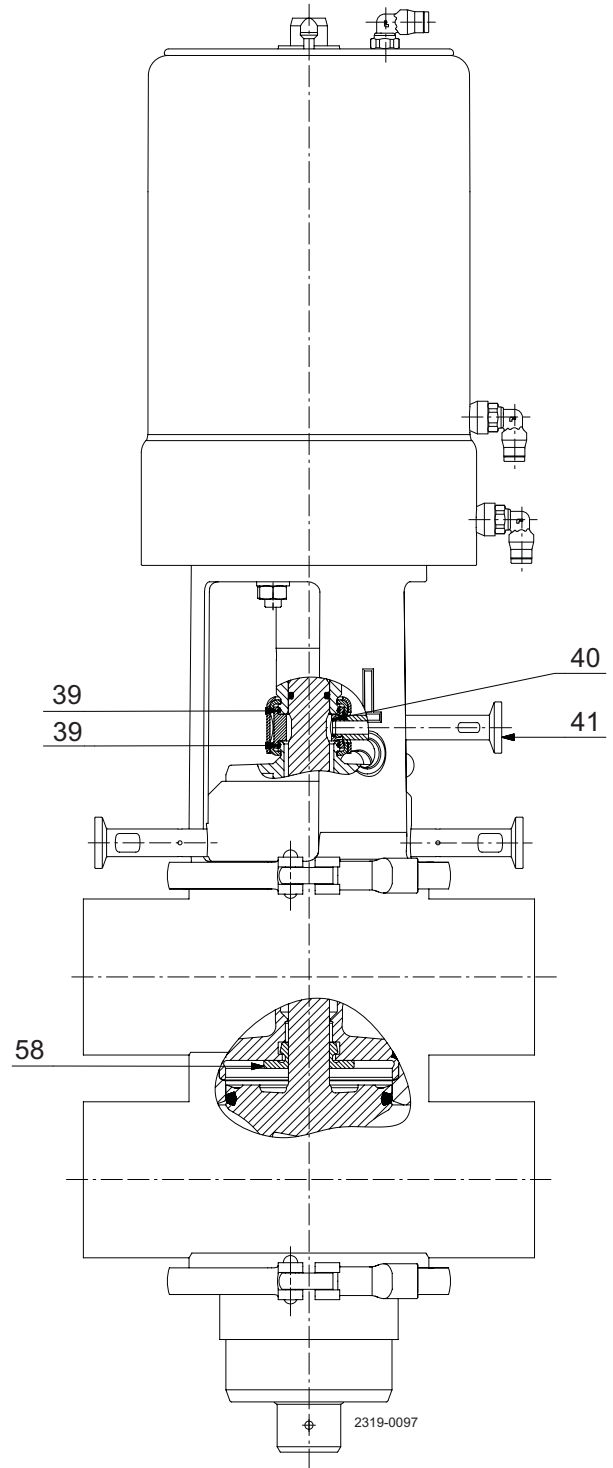

with SpiralClean in leakage chamber

- = Parts not used in all actuators
- * = Not used in 1½" and 2"
- ** = Not used in 2½", 3", 4" and 6"

8 Parts list and service kits

For spare parts please refer to spare parts catalogue.

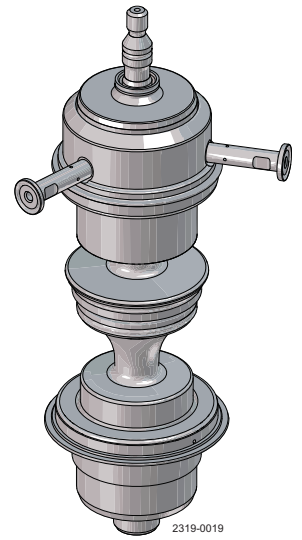
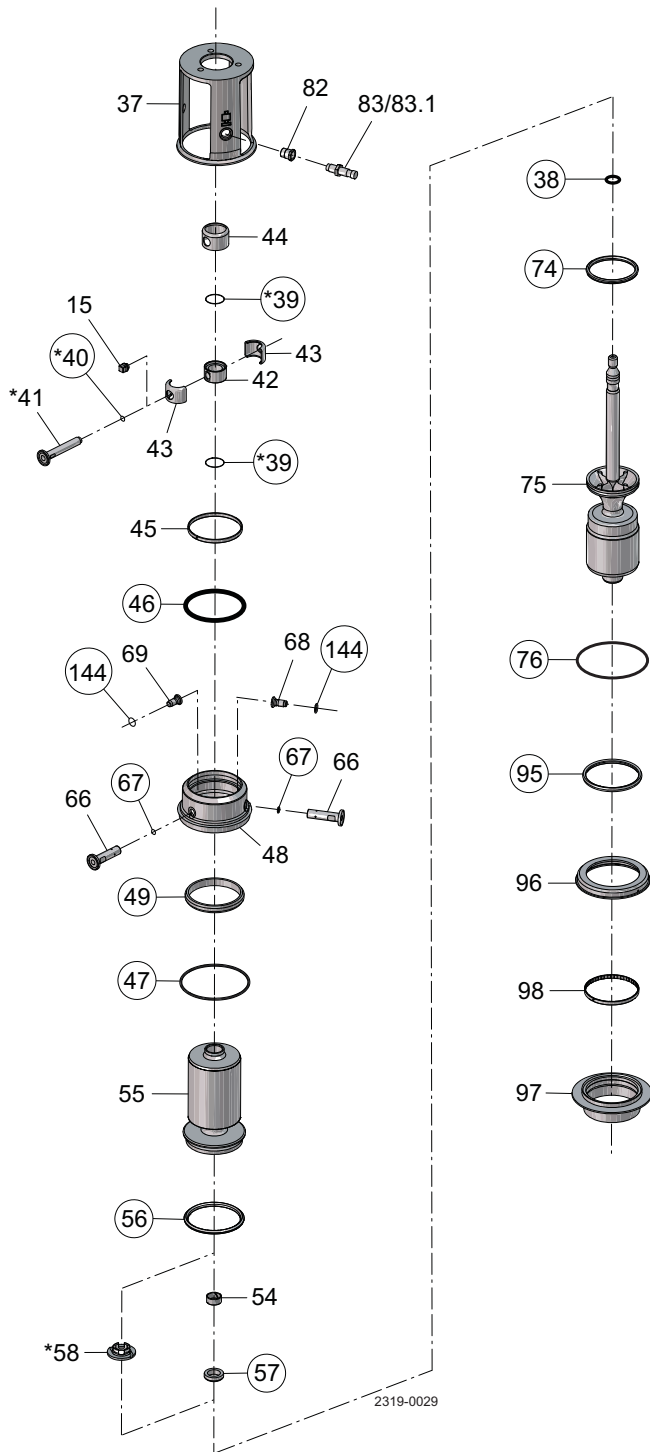

○ = wear parts

* = with SpiralClean in leakage chamber

8 Parts list and service kits

For spare parts please refer to spare parts catalogue.

Parts list

Pos.	Qty	Denomination
15	1	Plug
37	1	Intermediate piece
38	1	O-ring
39	2	O-ring
40	1	O-ring
41	1	Flushing tube
42	1	Spindle liner
43	2	Clamp
44	1	Lock
45	1	Guide ring
46	1	O-ring
47	1	O-ring
48	1	Upper sealing element
49	1	Lip seal
52	1	O-ring
54	1	Guide ring
55	1	Upper plug
56	1	Seal ring
57	1	Lip seal
58	1	Spray nozzle
66	2	Flushing tube
67	2	O-ring
68	1	Drain
69	1	Nozzle
74	1	Seal ring
75	1	Lower plug
76	1	O-ring
82	1	Bolt for indication
83	1	Sensor for indication
83.1	1	Cable for sensor for indication
95	1	Special lip seal
96	1	Lower sealing element
97	1	Lower sealing element
98	1	Guide ring, Turcite
144	2	O-ring

Service kits

Denomination	1½" Seat ø53.3	2" Seat ø53.3	2½" Seat ø81.3	3" Seat ø81.3	4" Seat ø100.3	6" Seat ø115.3
Service kit, EPDM	9611-92-8237	9611-92-8241	9611-92-8245	9611-92-8245	9611-92-8249	9611-92-8253
Service kit, NBR	9611-92-8238	9611-92-8242	9611-92-8246	9611-92-8246	9611-92-8250	9611-92-8254
Service kit, FPM	9611-92-8239	9611-92-8243	9611-92-8247	9611-92-8247	9611-92-8251	9611-92-8255
Service kit, HNBR	9611-92-8240	9611-92-8244	9611-92-8248	9611-92-8248	9611-92-8252	9611-92-8256

For mixed size housings, the service kit is determined by the smallest size connection on the valve.
One exception is any housing with 6" connections will always refer to the 6" service kits listed below:

Service kit, EPDM	9611-92-8305	9611-92-8309	9611-92-8313	9611-92-8313	9611-92-8317
Service kit, NBR	9611-92-8306	9611-92-8310	9611-92-8314	9611-92-8314	9611-92-8318
Service kit, FPM	9611-92-8307	9611-92-8311	9611-92-8315	9611-92-8315	9611-92-8319
Service kit, HNBR	9611-92-8308	9611-92-8312	9611-92-8316	9611-92-8316	9611-92-8320

8 Parts list and service kits

For spare parts please refer to spare parts catalogue.

8.13 Plug setup 19

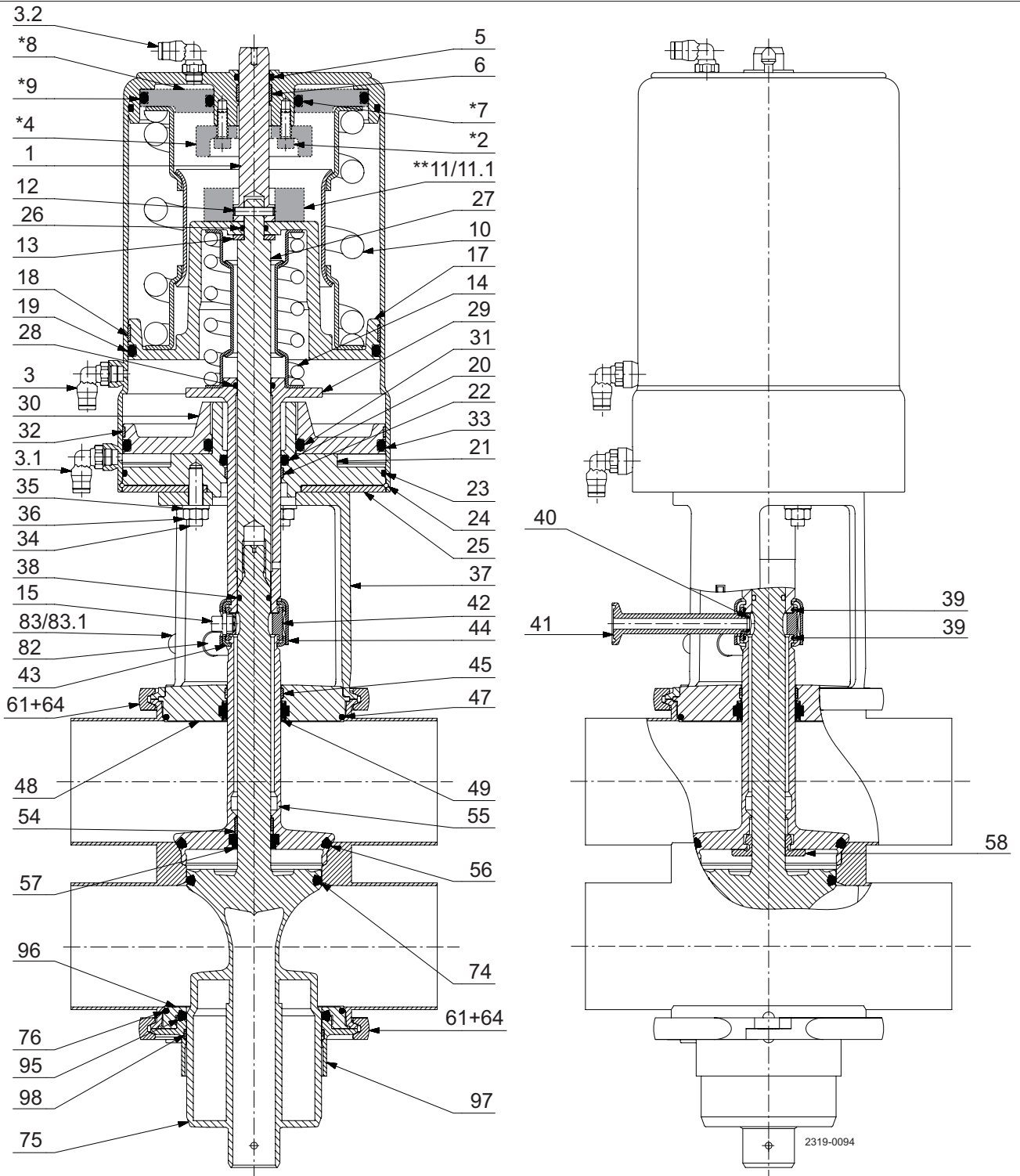

without SpiralClean in leakage chamber

with SpiralClean in leakage chamber

- = Parts not used in all actuators
- * = Not used in 1½" and 2"
- ** = Not used in 2½", 3", 4" and 6"

8 Parts list and service kits

For spare parts please refer to spare parts catalogue.

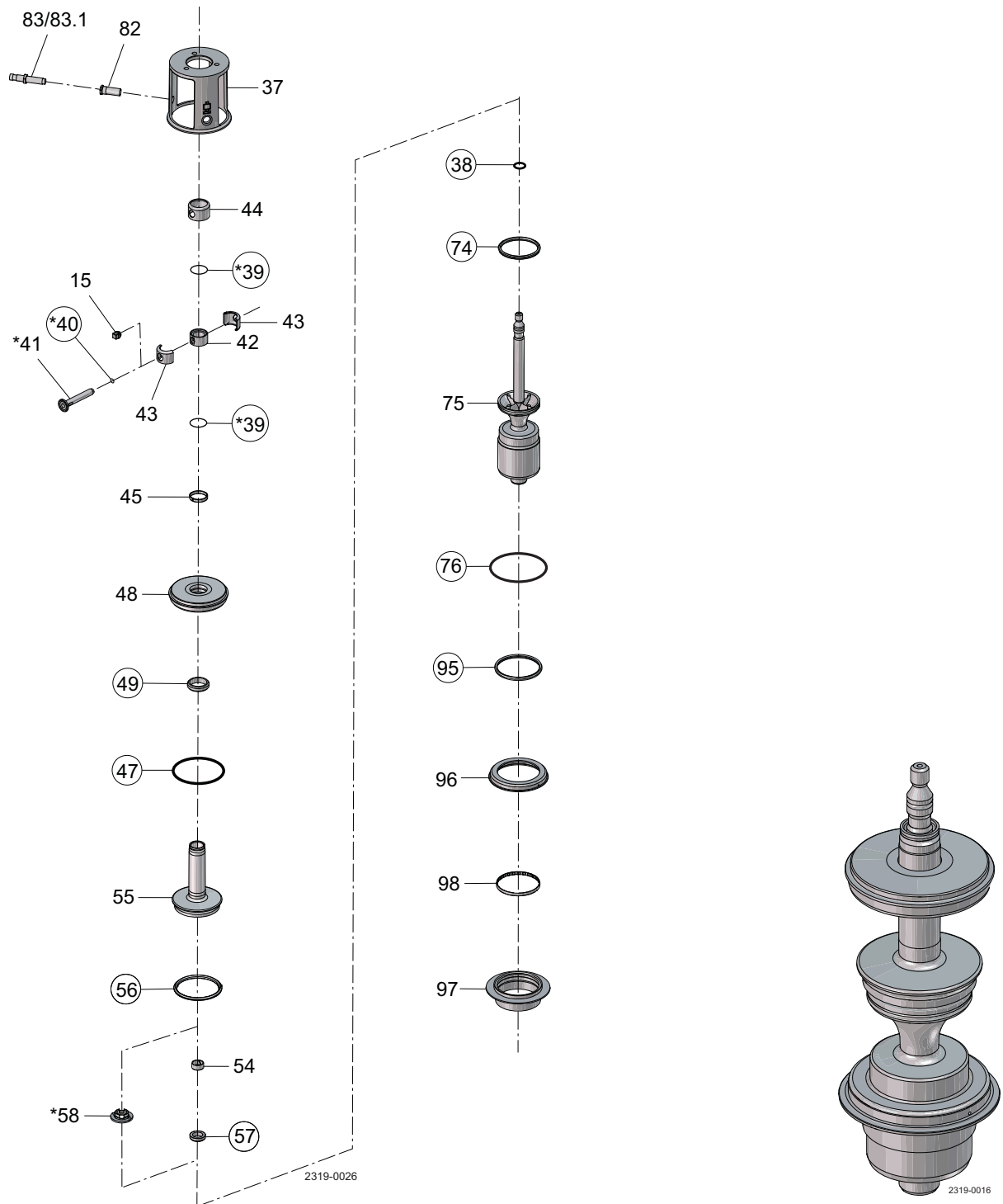

○ = wear parts

* = with SpiralClean in leakage chamber

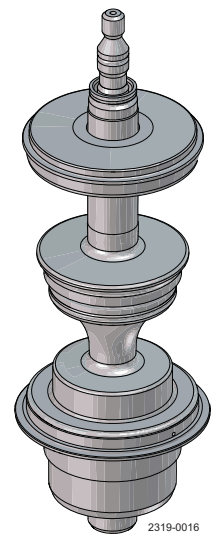

8 Parts list and service kits

For spare parts please refer to spare parts catalogue.

Parts list

Pos.	Qty	Denomination
15	1	Plug
37	1	Intermediate piece
38	1	O-ring
39	2	O-ring
40	1	O-ring
41	1	Flushing tube
42	1	Spindle liner
43	2	Clamp
44	1	Lock
45	1	Guide ring
47	1	O-ring
48	1	Upper sealing element
49	1	Lip seal
52	1	O-ring
54	1	Guide ring
55	1	Upper plug
56	1	Seal ring
57	1	Lip seal
58	1	Spray nozzle
74	1	Seal ring
75	1	Lower plug
76	1	O-ring
82	1	Bolt for indication
83	1	Sensor for indication
83.1	1	Cable for sensor for indication
95	1	Special lip seal
96	1	Lower sealing element, upper part
97	1	Lower sealing element, lower part
98	1	Guide ring, Turcite

Service kits

Denomination	2" Seat ø53.3	2½" Seat ø81.3	3" Seat ø81.3	4" Seat ø100.3	6" Seat ø115.3
Service kit, EPDM	9611-92-8257	9611-92-8261	9611-92-8261	9611-92-8265	9611-92-8269
Service kit, NBR	9611-92-8258	9611-92-8262	9611-92-8262	9611-92-8266	9611-92-8270
Service kit, FPM	9611-92-8259	9611-92-8263	9611-92-8263	9611-92-8267	9611-92-8271
Service kit, HNBR	9611-92-8260	9611-92-8264	9611-92-8264	9611-92-8268	9611-92-8272

For mixed size housings, the service kit is determined by the smallest size connection on the valve.

One exception is any housing with 6" connections will always refer to the 6" service kits listed below:

Service kit, EPDM	9611-92-8321	9611-92-8325	9611-92-8325	9611-92-8329
Service kit, NBR	9611-92-8322	9611-92-8326	9611-92-8326	9611-92-8330
Service kit, FPM	9611-92-8323	9611-92-8327	9611-92-8327	9611-92-8331
Service kit, HNBR	9611-92-8324	9611-92-8328	9611-92-8328	9611-92-8332

8 Parts list and service kits

For spare parts please refer to spare parts catalogue.

8.14 Plug setup 20

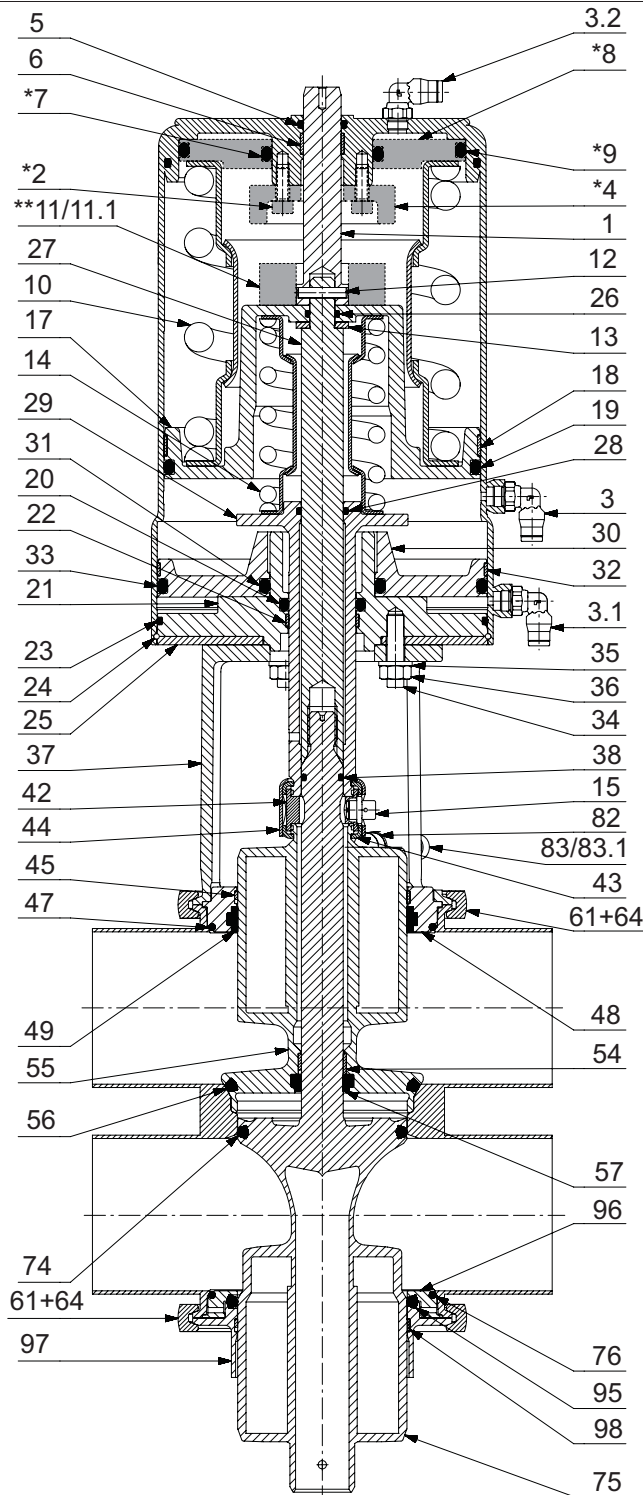

without SpiralClean in leakage chamber

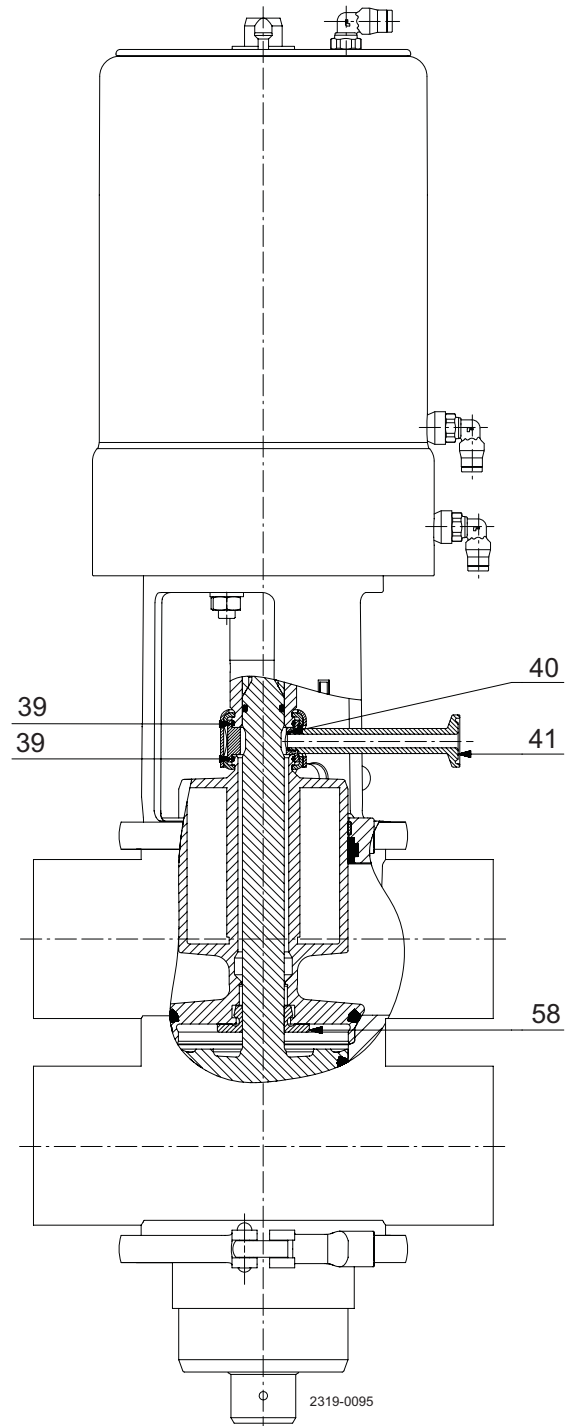

with SpiralClean in leakage chamber

■ = Parts not used in all actuators

* = Not used in 1½" and 2"

** = Not used in 2½", 3", 4" and 6"

8 Parts list and service kits

For spare parts please refer to spare parts catalogue.

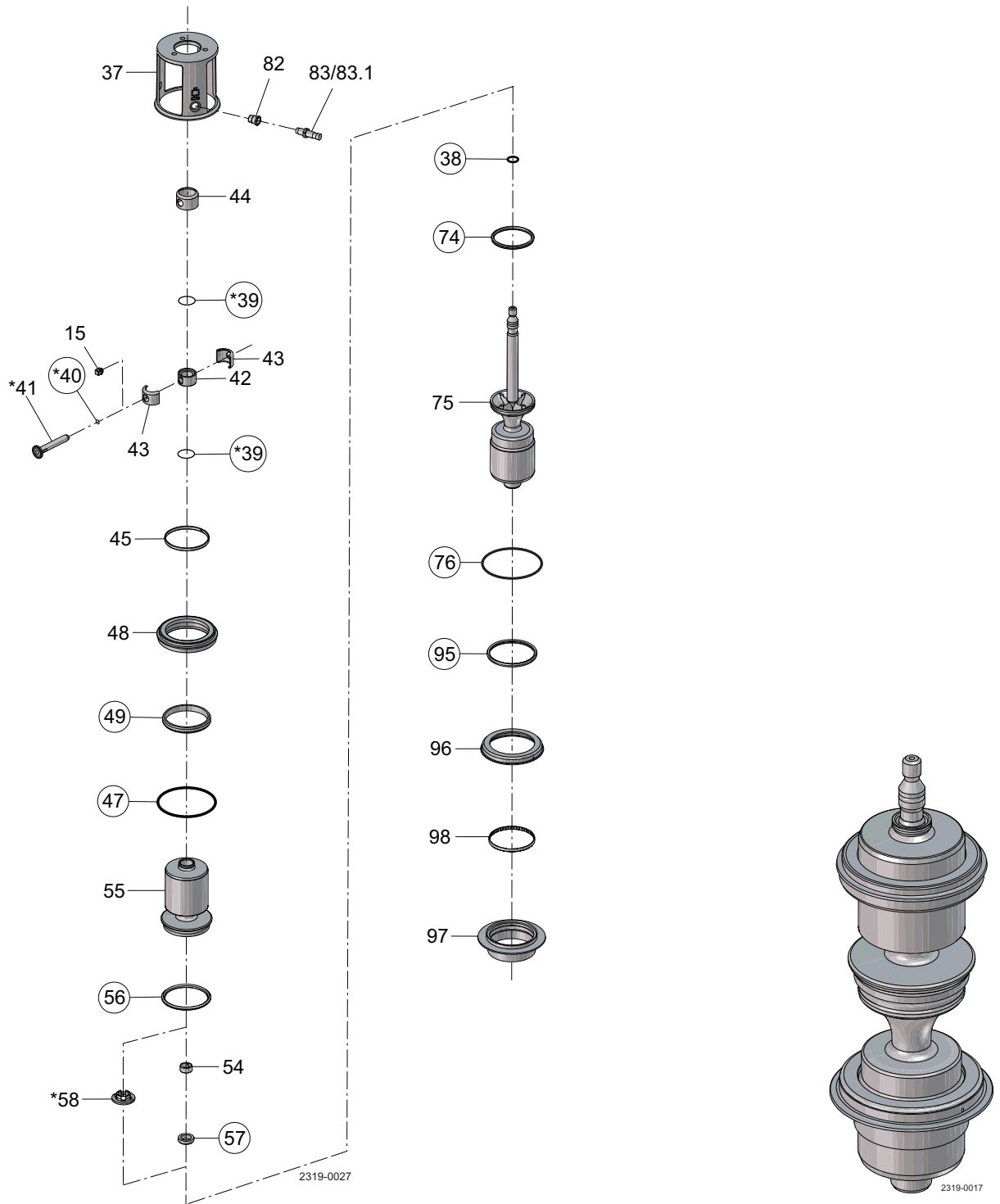

8 Parts list and service kits

For spare parts please refer to spare parts catalogue.

Parts list

Pos.	Qty	Denomination
15	1	Plug
37	1	Intermediate piece
38	1	O-ring
39	2	O-ring
40	1	O-ring
41	1	Flushing tube
42	1	Spindle liner
43	2	Clamp
44	1	Lock
45	1	Guide ring
47	1	O-ring
48	1	Upper sealing element
49	1	Lip seal
52	1	O-ring
54	1	Guide ring
55	1	Upper plug
56	1	Seal ring
57	1	Lip seal
58	1	Spray nozzle
75	1	Lower plug
76	1	O-ring
82	1	Bolt for indication
83	1	Sensor for indication
83.1	1	Cable for sensor for indication
95	1	Special lip seal
96	1	Lower sealing element, upper part
97	1	Lower sealing element, lower part
98	1	Guide ring, Turcite

Service kits

Denomination	1½"	2"	2½"	3"	4"	6"
	Seat ø53.3	Seat ø53.3	Seat ø81.3	Seat ø81.3	Seat ø100.3	Seat ø115.3
Service kit, EPDM	9611-92-8273	9611-92-8277	9611-92-8281	9611-92-8281	9611-92-8285	9611-92-8289
Service kit, NBR	9611-92-8274	9611-92-8278	9611-92-8282	9611-92-8282	9611-92-8286	9611-92-8290
Service kit, FPM	9611-92-8275	9611-92-8279	9611-92-8283	9611-92-8283	9611-92-8287	9611-92-8291
Service kit, HNBR	9611-92-8276	9611-92-8280	9611-92-8284	9611-92-8284	9611-92-8288	9611-92-8292

For mixed size housings, the service kit is determined by the smallest size connection on the valve.

One exception is any housing with 6" connections will always refer to the 6" service kits listed below:

Service kit, EPDM	9611-92-8333	9611-92-8337	9611-92-8341	9611-92-8341	9611-92-8345
Service kit, NBR	9611-92-8334	9611-92-8338	9611-92-8342	9611-92-8342	9611-92-8346
Service kit, FPM	9611-92-8335	9611-92-8339	9611-92-8343	9611-92-8343	9611-92-8347
Service kit, HNBR	9611-92-8336	9611-92-8340	9611-92-8344	9611-92-8344	9611-92-8348

8 Parts list and service kits

For spare parts please refer to spare parts catalogue.

8.15 Valve body

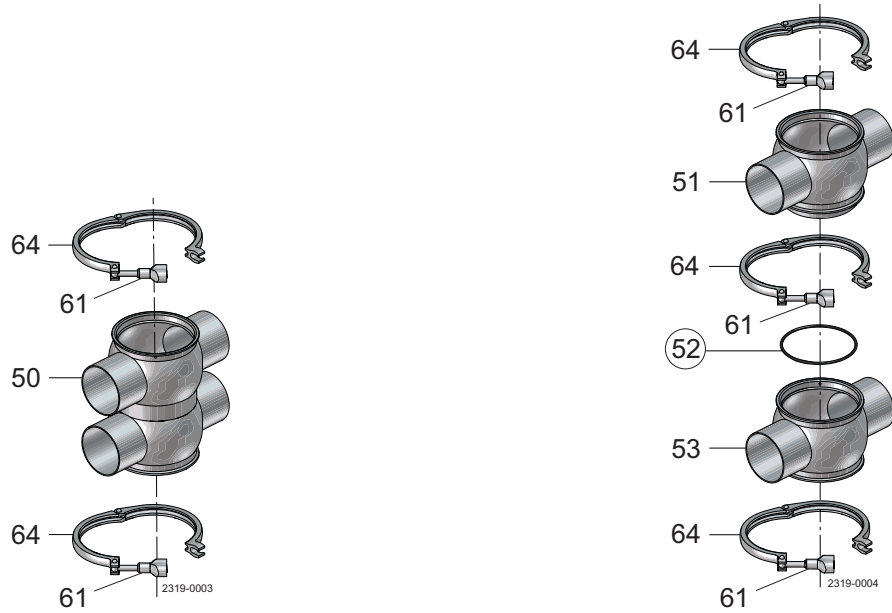

Body combination - welded bodies

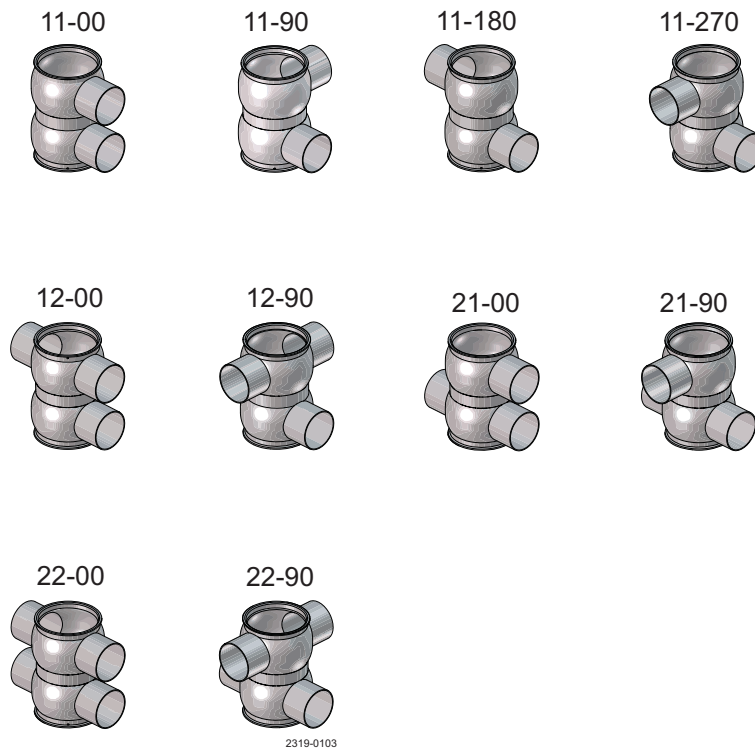

For spare parts please refer to spare parts catalogue.

Parts list

Pos.	Qty	Denomination
50	1	Valve body
51	1	Valve body, upper
52	1	O-ring
53	1	Valve body, lower
61	2	Wingnut
64	2	Clamp without nut

8 Parts list and service kits

For spare parts please refer to spare parts catalogue.

8.16 Axial installation tool (upper plug)

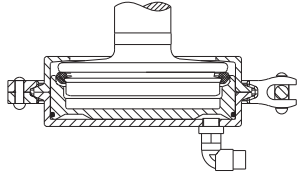
Item No.	Item No.	Item No.	Item No.	
1½" + 2" Seat ø53.3	2½" + 3" Seat ø81.3	4" Seat ø100.3	6" Seat ø115.3	Tool for axial sealing, upper plug
9613050501	9613050502	9613050508	9613050503	 TD 449-033

For spare parts please see spare parts catalogue.

8 Parts list and service kits

For spare parts please refer to spare parts catalogue.

8.17 Radial installation tool (lower plug)

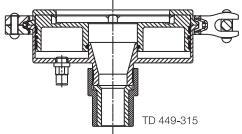
Item No.	Item No.	Item No.	Item No.	
1½" + 2" Seat ø53.3	2½" + 3" Seat ø81.3	4" Seat ø100.3	6" Seat ø115.3	Tool for radial sealing, lower plug
9613426001	9613426002	9613426003	9613426004	 TD 449-315

For spare parts please see spare parts catalogue.

How to contact Alfa Laval

Contact details for all countries are continually updated on our website.

Please visit www.alfalaval.com to access the information directly.

© Alfa Laval Corporate AB

This document and its contents is owned by Alfa Laval Corporate AB and protected by laws governing intellectual property and thereto related rights. It is the responsibility of the user of this document to comply with all applicable intellectual property laws. Without limiting any rights related to this document, no part of this document may be copied, reproduced or transmitted in any form or by any means (electronic, mechanical, photocopying, recording, or otherwise), or for any purpose, without the expressed permission of Alfa Laval Corporate AB. Alfa Laval Corporate AB will enforce its rights related to this document to the fullest extent of the law, including the seeking of criminal prosecution.