

Instruction Manual



Anderson Instrument Co., Inc.
156 Auriesville Road
Fultonville, NY 12072
Phone: 800-833-0081
www.anderson-negele.com

ANDERSON-NEGELE

RODEM[®]
PROCESS EQUIPMENT
www.rodem.com 800-543-7312

Instrument Model Number _____

Instrument Serial Number _____

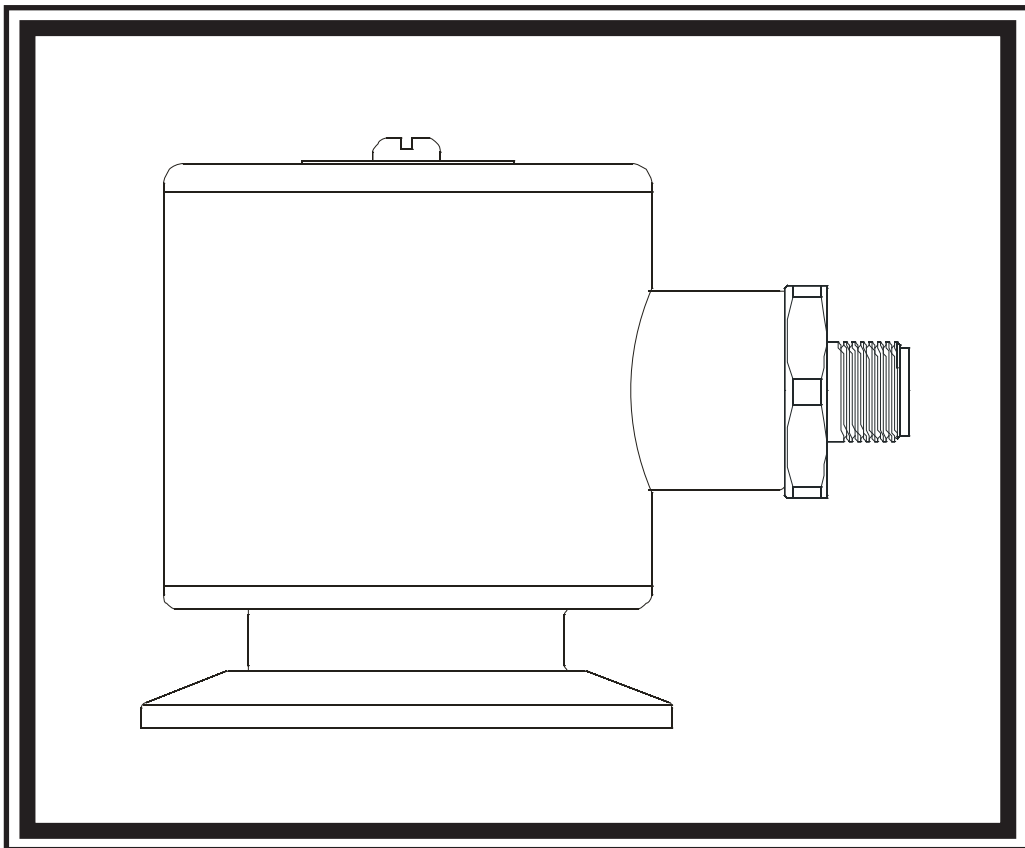

HB Series Mini Level Sensor

Form Number AIC2006
© May 1998
Revised: 6/14
Supersedes: 5/14

Section 1 - Ordering Matrix

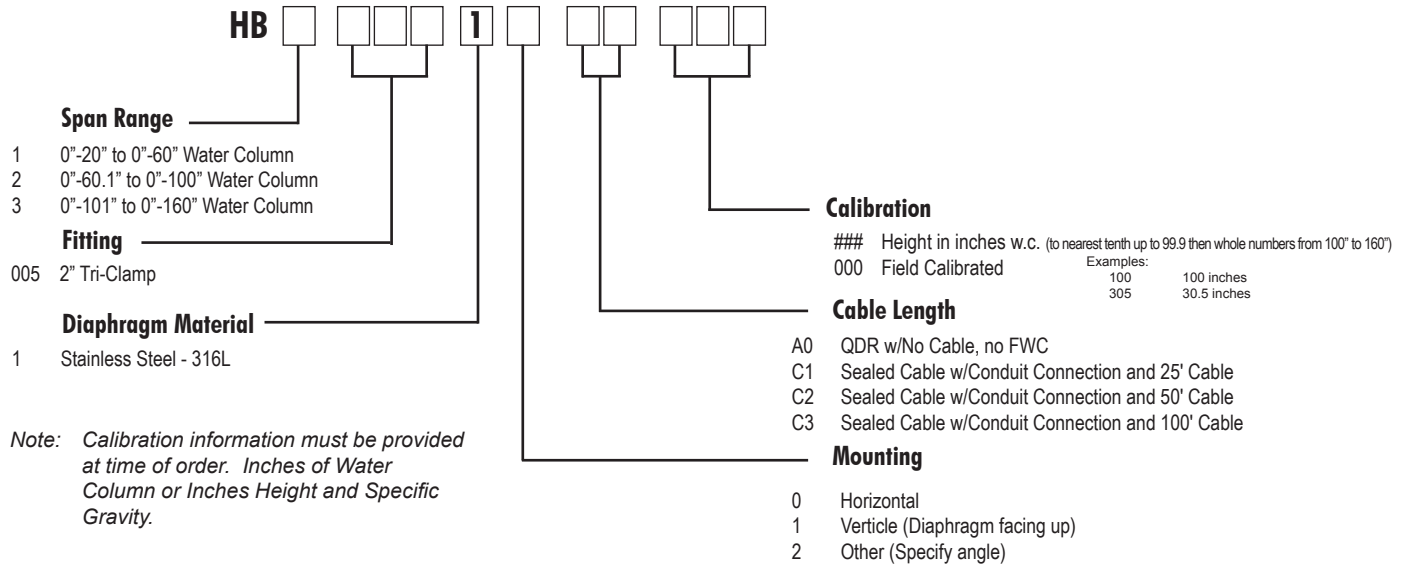

Section 2 - Specifications

Environmental Specifications

Ambient Operating Temperature Range: 40°F to 120°F (4°C to 49°C)
 Storage Temperature Range: -40°F to 250°F (-40°C to 121°C)
 Humidity: 0 to 95% RH, condensing

Material / Construction

Housing: 304 Stainless Steel, R_a 40 maximum finish
 Wetted Parts: 316L Stainless Steel, R_a 25 maximum finish
 Process Connection: 2" Tri-Clamp

Approvals & Documentation

Ratings: NEMA 4X/IP-66, IP-67 3A Authorized Models equipped with optional conduit connector must be installed with conduit to maintain

Standards: Designed and manufactured to sound engineering practices in accordance with Article 3.3 of the PED 97/23/EC
 CSA B51-03
 CRN# CSA0F9754.5C

Operating Specifications

Range: HB1 0-20" to 0-60" Water Column
 HB2 0-60.1" to 0-100" Water Column
 HB3 0-101" to 0-160" Water Column
 2.5 times Upper Range Limit

Over-Range Capacity: 200 uSec

Response Time: Factory calibrated to ±0.2% of Upper Range Limit (URL) Stabilized at 75°F (24°C)

Accuracy: 32°F to 250°F (0°C to 121°C)
 Compensated 32°F to 200°F (0°C to 93°C)

Process Temperature Limits: Within ±2.0"/100°F over the compensated process and ambient operational temperature range

Temperature Stability:

Power / Signal / Electrical

Voltage: 12-40 VDC
 Load Impedance: 1400 ohms (max) @ 40 VDC
 Output: 4-20 mA DC, 2-wire
 Electrical Connection: Standard - 5 pin M12
 Pins 1 & 2 Active

Figure 1 Dimensions

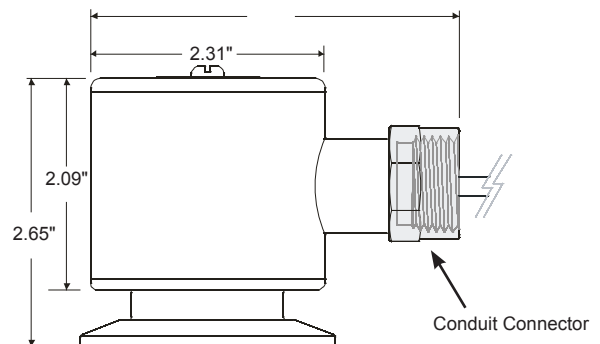
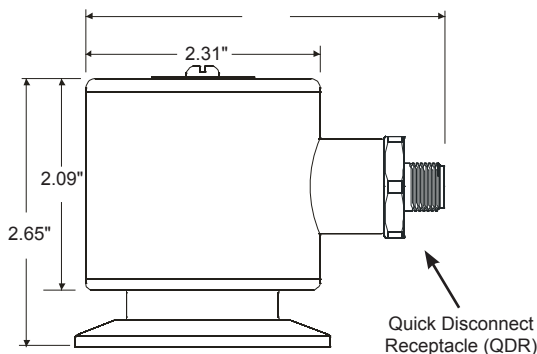

Recommended Cable: Shielded 5 pin M12 molded cordset
 Pins 1 & 2 Active, Shield must connect to cordset nut

Optional: Sealed Cable with 1/2" NPT Conduit Connection

Section 3 Description

The *HB Series Mini-Level Transmitter* is an integral unit designed to measure static head pressure (level) in *Pasteurization Loop Balance Tanks* and small *Open Atmosphere Sanitary Storage Vessels*. The unit converts head pressure exerted by the product into a proportional 4-20 mA DC signal. This signal may feed instrumentation such as controllers or digital indicators. The all stainless sealed design meets the demands of damp or wet applications, and may be directly washed down during normal cleanup. Units are typically shipped pre-calibrated from the Factory, with provisions provided for field calibration via onboard adjustment potentiometers (Pots).

Section 4 Wiring

A 12 to 40 VDC loop power source is required for operation of the HB transmitter. If below 24 VDC, it is recommended that a regulated supply be utilized.

HB mini level transmitters are provided with either the standard M12 5 pin quick disconnect receptacle or with a 1/2" NPT conduit connector option that includes a sealed four conductor, foil shielded sealed cable connection.

Anderson recommends Molded cord-set P/N 42117H0025, 0050, 0100 for lengths 25ft, 50ft or 100ft. This is a premium molded cord-set designed to meet both the electrical and environmental requirements of the HB. Commercially available cord-sets may be used as long as shielding is connected to the attachment nut.

For HB ordered with the conduit connection option conduit must be installed to meet environmental protection rating. Conductor assignments as follows:.

RED	=	Loop (+) connection
BLACK	=	Loop (-) connection
GREEN	=	Not Used
WHITE	=	Not Used
GROUND	=	Attached at sensor

NOTE: If it becomes necessary to splice cable connections, be sure all joints are properly soldered and sealed from moisture. As copper easily becomes contaminated from typical cleaning solutions, poor quality connections will eventually affect 4-20 mA signal output of the transmitter.

Figure 2 Wiring Diagram

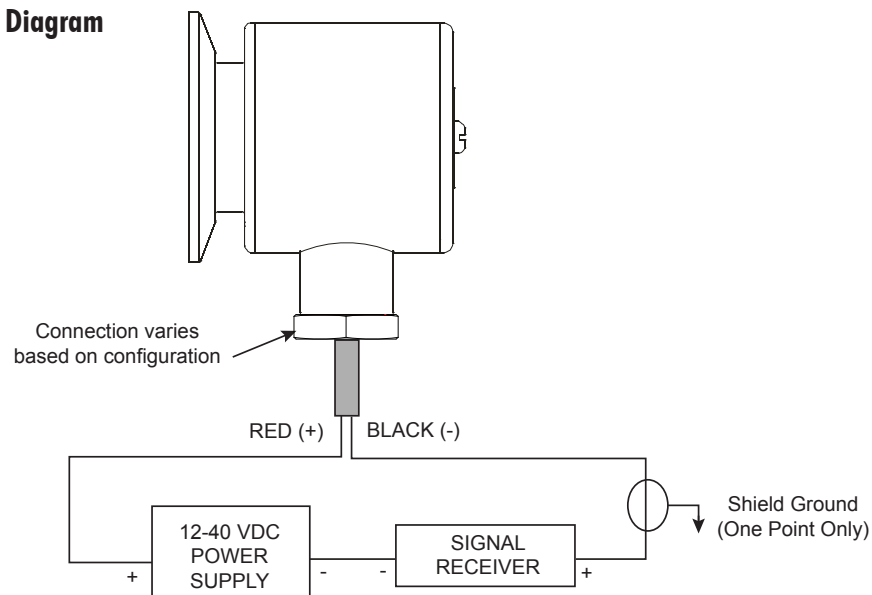

Section 5 Transmitter Electronic Zero Calibration

Upon installation, and at typical six month intervals, a Zero calibration adjustment must be performed. The required procedure is as follows:

Tools required: Digital Multimeter (Known accurate)
Fine - straight bladed screwdriver

NOTE: Must be performed with the sensor installed in the vessel, with appropriate loop power applied.

Be sure vessel is drained to a level at or below the sensor. The transmitter should be wired to the receiver at this point. To prevent possibly shorting receiver inputs, it is recommended that loop power be shut off while making test equipment connections. At the receiver, remove the (-) BLACK transmitter lead. Connect the (+) RED meter lead to the transmitter lead just removed. Connect the (-) BLACK meter lead to the resulting empty terminal in the receiver. The digital multimeter should be set in the mA DC mode. At this point, apply loop power again taking note of the resulting meter reading. You should see 4.00 mA registering on the meter display. If not, remove the screw at the end of the sensor labeled "ZERO". Using the fine screwdriver, adjust the internal potentiometer until a reading of 4.00 mA is achieved. Once complete, replace the protective screw over the Zero potentiometer. Remove test equipment and install transmitter (-) BLACK lead back to receiver. Again, it is recommended that loop power be shut off while disconnecting equipment to prevent shorting of the receiver inputs.

Figure 3 Zero Adjustments

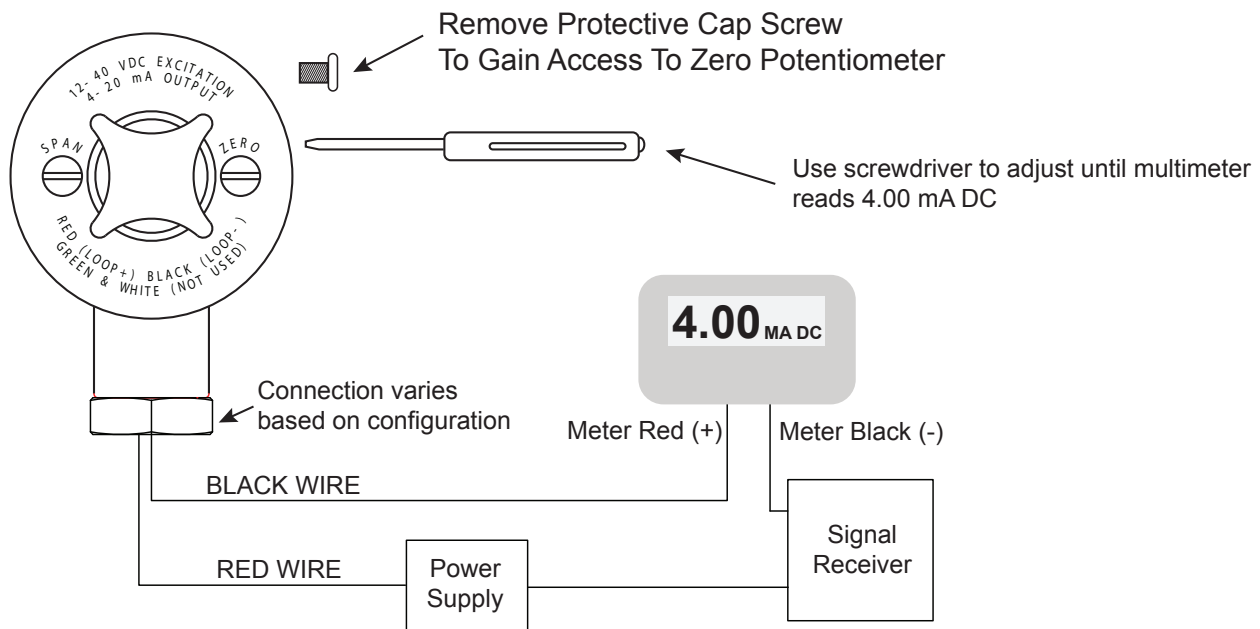

Section 6 Calibration Ranges and Adjustments

The HB series transmitter is typically supplied pre-calibrated from the factory. Calibration data is located on the information stamping on the side housing:

CAL. RANGE: XXXXXXXXX (Factory Calibrated Range In Inches Of Water Column)

Calibration checks may be performed in the field using known accurate pressure test equipment. Typical devices read out directly in Inches of Water Column where 27.7" Water Column equals 1 psig. As the required calibration pressures are very low, it is recommended that a test gauge having a direct Inches Water Column scale be used. This will give the greatest resolution. In some instances, it may be required to alter calibration, or perform calibration of the transmitter in the field. Keep in mind that two ranges exist. A transmitter supplied in the lower range cannot be re-spanned to operate in the higher range, and vice versa. Calibration adjustments within the same base range are allowed. The procedure for adjustment is as follows:

Calibration Using Pressure Simulator

- Be sure sensor is properly wired to loop power - remove Zero and Span protective cap screws
- Attach multimeter as in Figure 3 (Readout in mA DC)
- Attach pressure calibration equipment
- Orient sensor as close as possible to position as if it were installed in vessel
- Perform ZERO potentiometer adjustment with NO pressure on transmitter (Meter to read 4.00 mA)
- Apply test pressure to transmitter
- Perform SPAN potentiometer adjustment on transmitter (Meter to read 20.00 mA)
- Replace sensor into vessel
- Perform ZERO potentiometer adjustment with NO pressure on transmitter (Meter to read 4.00 mA)
- Zero and Span are non-interactive - calibration is complete - replace protective cap screws

Calibration Using Product in Vessel

- Be sure sensor is properly wired to loop power - remove Zero and Span protective cap screws
- Attach multimeter as in Figure 3 (Readout in mA DC)
- Perform ZERO potentiometer adjustment with NO product on transmitter (Meter to read 4.00 mA)
- Fill tank to capacity with PRODUCT
- Perform SPAN potentiometer adjustment on transmitter (Meter to read 20.00 mA)
- Zero and Span are non-interactive - calibration is complete - replace protective cap screws

Calibration Using Water in Vessel

Specific Gravity = (Pounds Per Gallon for Product / 8.345)

- Calibration with water in a vessel that will hold another product requires Specific Gravity correction
- Determine Specific Gravity, or calculate if Pounds Per Gallon provided
- Correct for Specific Gravity: $[(16.00 \text{ mA} / \text{Specific Gravity}) + 4.00 \text{ mA}] = \text{Expected mA Signal}$
- Be sure sensor is properly wired to loop power - remove Zero and Span protective cap screws
- Attach multimeter as in Figure 3 (Readout in mA DC)
- Perform ZERO potentiometer adjustment with NO product on transmitter (Meter to read 4.00 mA)
- Fill tank to capacity with WATER
- Perform SPAN potentiometer adjustment on transmitter (Meter to read result of calculation performed above)
- Zero and Span are non-interactive - calibration is complete - replace protective cap screws

Contact Anderson Instrument Technical Services for further assistance

Please have Model and Serial number available

Warranty and Return Statement

These products are sold by The Anderson Instrument Company (Anderson) under the warranties set forth in the following paragraphs. Such warranties are extended only with respect to a purchase of these products, as new merchandise, directly from Anderson or from an Anderson distributor, representative or reseller, and are extended only to the first buyer thereof who purchases them other than for the purpose of resale.

Warranty

These products are warranted to be free from functional defects in materials and workmanship at the time the products leave the Anderson factory and to conform at that time to the specifications set forth in the relevant Anderson instruction manual or manuals, sheet or sheets, for such products for a period of one year.

THERE ARE NO EXPRESSED OR IMPLIED WARRANTIES WHICH EXTEND BEYOND THE WARRANTIES HEREIN AND ABOVE SET FORTH. ANDERSON MAKES NO WARRANTY OF MERCHANTABILITY OR FITNESS FOR A PARTICULAR PURPOSE WITH RESPECT TO THE PRODUCTS.

Limitations

Anderson shall not be liable for any incidental damages, consequential damages, special damages, or any other damages, costs or expenses excepting only the cost or expense of repairs or replacement as described above.

Products must be installed and maintained in accordance with Anderson instructions. Users are responsible for the suitability of the products to their application. There is no warranty against damage resulting from corrosion, misapplication, improper specifications or other operating condition beyond our control. Claims against carriers for damage in transit must be filed by the buyer.

This warranty is void if the purchaser uses non-factory approved replacement parts and supplies or if the purchaser attempts to repair the product themselves or through a third party without Anderson authorization.

Returns

Anderson's sole and exclusive obligation and buyer's sole and exclusive remedy under the above warranty is limited to repairing or replacing (at Anderson's option), free of charge, the products which are reported in writing to Anderson at its main office indicated below.

Anderson is to be advised of return requests during normal business hours and such returns are to include a statement of the observed deficiency. The buyer shall pre-pay shipping charges for products returned and Anderson or its representative shall pay for the return of the products to the buyer.

An RMA (Return Merchandise Authorization) must be obtained from Anderson Customer Service before returning merchandise.

Approved returns should be sent to:

Anderson Instrument Co., Inc.
156 Auriesville Rd.
Fultonville, NY 12072

ATTN: Repairs

Write RMA number on outside of package