

# Instruction Manual



ANDERSON-NEGELE

Anderson Instrument Co. Inc.  
156 Auriesville Road  
Fultonville, NY 12072  
1-800-833-0081  
Fax 518-922-8997  
[www.anderson-negele.com](http://www.anderson-negele.com)

**RODEM**<sup>®</sup>  
PROCESS EQUIPMENT  
[www.rodem.com](http://www.rodem.com) 800-543-7312

Instrument Model Number \_\_\_\_\_

Instrument Serial Number \_\_\_\_\_



## **MODEL RSP SANITARY ELECTRONIC PRESSURE TRANSMITTER**

Form Number AIC3529  
© Sept. 1994 ~ Rev. 10/02

---

## **Table of Contents**

	<b>Page Number</b>
<b>SECTION 1 - INTRODUCTION</b>	<b>3</b>
1.1 SPECIFICATIONS	3
<b>SECTION 2 - THEORY OF OPERATION</b>	<b>5</b>
<b>SECTION 3 - INSTALLATION</b>	<b>5</b>
<b>SECTION 4 - SENSOR WIRING</b>	<b>6</b>
<b>SECTION 5 - INSTRUMENT WIRING</b>	<b>7</b>
5.1 LOOP POWER	7
<b>SECTION 6 - LIQUID CRYSTAL DISPLAY</b>	<b>8</b>
6.1 LCD INSTALLATION	8
<b>SECTION 7 - MAINTENANCE</b>	<b>8</b>
<b>SECTION 8 - CALIBRATION</b>	<b>9</b>
8.1 CALIBRATION OF TRANSMITTER	9
8.2 CALIBRATION OF LCD DISPLAY	9
<b>SECTION 9 - TROUBLESHOOTING</b>	<b>12</b>
9.1 VOLTAGE CHECK	12
9.2 CURRENT CHECK	12
9.3 MISCELLANEOUS TROUBLESHOOTING	12
<b>SECTION 10 - WARRANTY AND RETURN STATEMENT</b>	<b>13</b>
<b>FIGURES</b>	
1 Dimensional View	3
2 Wiring Terminal Connections	6
3 Loop Power Guidelines	7
4 Loop Diagram	7
5 LCD Display Calibration Adjustments	10

## Section 1 - Introduction

This manual has been designed to assist the end-user with the installation of the Anderson model RSP Sanitary Electronic Pressure Transmitter. When followed properly, your sensor will provide optimum performance with minimum maintenance.

FIGURE 1 - Dimensional View

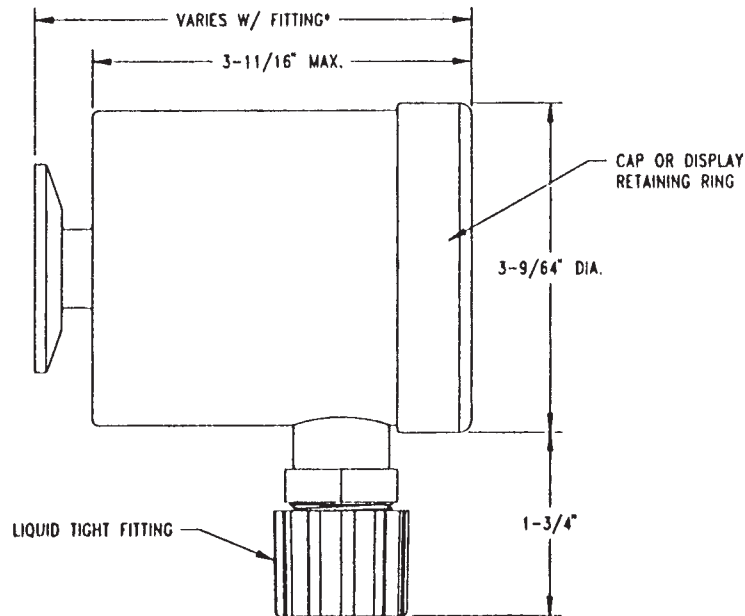

\*SHOWN WITH 1-1/2" TRI-CLAMP

### 1.1 SPECIFICATIONS

Excitation:	9-32 VDC (Absolute), 24 VDC Nominal, regulated or unregulated 14-37 VDC (Absolute) with display
Output:	4-20 mA DC
Loop Resistance:	0-750 ohms at 24 VDC 0-1050 ohms at 30 VDC
Indication:	Optional, 3 1/2 digit, .5" high LCD, cap mounted
Accuracy:	±.5% of span, full scale, for standard ranges, ranges below 0-50 psig ± 1% full scale; all compound and psia ranges, ± 1.5% full scale
Over-Range Rating:	2 times base range
Stability:	± 0.3% of calibrated range/6 months
Storage Temperature:	-40 to 150°F (-40 to 65°C)
Zero and Span Adjustment:	± 10% of range
Repeatability:	± .3%

## PAGE 4

Hysteresis:	± .2%
Process Temp. Range:	20° to 225°F (up to 300°F if horizontal mount)
Process Temp. Effect:	Less than 0,2% of full scale output/10°F change
Ambient Temp. Operating Range:	0° to 120°F (-17.8° to 48.9°C)
Storage Temperature:	-40° to 149°C (-40° to 65°C)
Mounting:	Direct connection
Housing Material:	304 Stainless Steel
Wetted Parts: optional	316L Stainless Steel standard; Hasteloy "C" diaphragm
Surface Finish (wetted parts):	$R_a$ = 25 microinches (.6 microns) for standard finish; $R_a$ max = 8 microinches (.2 microns) for electropolished fittings (specify when ordering)
Recommended Cable:	18-24 AWG, foil shielded, and PVC coated. (3/16" - 1/4" O.D. insulation)
Wiring Connection:	Screw Terminal; Accessible via removable screw cap conduit housing

---

## **Section 2 - Theory of Operation**

The Anderson RSP Pressure Transmitter can be utilized for applications in which a process variable of pressure must be converted to an electronic signal. This unit utilizes an internal pressure transducer to convert the process measurement into a corresponding mV signal. The mV signal then passes through custom linearization and conditioning circuitry. The resulting signal is an industry standard 4-20 mA. This mA signal is factory set over the specified range of the unit. From here the signal may be sent to an Anderson Digital Display, Microprocessor based controller, chart recorder, or customer supplied instrumentation. In addition, the RSP may be supplied with an integral LCD display for readout directly at the process.

---

## **Section 3 - Installation**

The physical installation is the most important concern with regards to promoting sensor reliability. Sensors must be installed in such a way that the housing and cable are not subject to physical abuse. In addition, moisture or moist air must not be allowed to enter the sensor housing or cable.

*NOTE: The installer assumes responsibility for preventing water or water-vapor from entering the sensor housing.*

Your new RSP transmitter is supplied with a conduit housing. If mounted horizontally, the conduit connection should point downward. Also, to prevent entry of excessive moisture, it is highly recommended that flexible conduits not be connected directly to the sensor. If conduit is to be run to the sensor, it is preferable that the watertight connector provided with each sensor not be removed from the sensor. Instead, run the flexible conduit as near to the sensor as possible and utilize a seal-tight connector at the end of the conduit. Allow a short amount of cable to run between the sensor and the flexible conduit. This isolates the sensor housing from the conduit system and any moisture it may contain. If the conduit is connected directly to the sensor, the chances are high that the sensor will eventually fail due to excessive water or water vapor entry into the housing.

*NOTE: It is recommended that a sensor "ZERO" be performed at time of installation. Refer to section 8.1, page 9 for information on this procedure.*

## Section 4 - Sensor Wiring

Anderson recommends a cable of 24 gauge, 4 conductor, shielded (Belden #9534) or equivalent. Four conductor cable is utilized because of its roundness, which provides a suitable seal when used with seal-tight connectors, strain reliefs and rubber grommets. Irregular shaped cable does not allow for a watertight seal.

If utilizing customer supplied cable, select a round cable with 22-24 AWG wire and a shield. In order for the Anderson provided seal-tight connector to seal on the cable, the O.D. of the cable must be between 3/16" and 1/4". If smaller cable is utilized, a different neoprene bushing must be used (must be customer supplied).

If an alternate seal-tight type connector is going to be used, be absolutely certain that the rubber bushing will adequately seal on the cable. Do not use a connector intended for power cable (large inside diameter) if the sensor cable is only 1/4". Be sure to use Teflon thread tape when attaching the new seal-tight connector.

Wiring to the conduit housing sensors is accomplished as follows:

1. Remove the housing cap to expose the wiring terminal block.
2. Insert the cable through the seal-tight connector, stripping back approximately 2 inches of sheathing to expose the wires.
3. Two wires will be utilized for connections at the transmitter end of the loop. Normal color codes being RED (Loop +) and BLACK (Loop -). Trim off all unused wires, including the bare shield ground wire. To prevent a GROUND LOOP condition, be sure the shield material and the shield ground wire do not touch the sensor housing. Use an insulator such as electrical tap or heat shrink tubing if necessary.
4. Strip the tips of the remaining wires back approximately 3/8 of an inch and twist strands (tinning is highly recommended).
5. Using Figure 2, make the proper connections to the wiring terminal strip (located inside the conduit housing)

Figure 2 - Wiring Terminal Connections

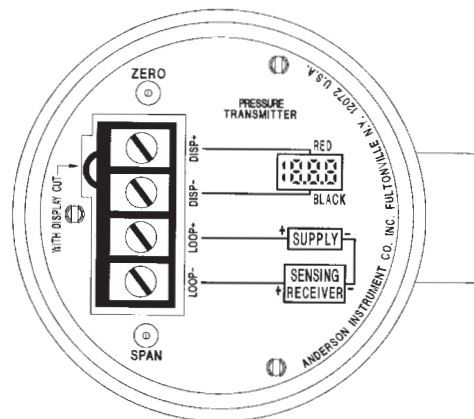

SHOWN WITH CAP/DISPLAY REMOVED

## Section 5 - Instrument Wiring

With the proper wiring connections made at the sensor end of the loop, it is now time to make final connections at the instrument end of the loop. The RSP may feed instruments such as Anderson digital display, microprocessor based controllers, chart recorders, or customer supplied instrumentation.

### 5.1 LOOP POWER

The Anderson RSP requires loop power for operation. Ratings are as follows:

Standard RSP Transmitter: 9-32 VDC (Absolute), 24 VDC Nominal, regulated or unregulated

RSP Transmitter with LCD Display: 14-37 VDC (Absolute), 24 VDC Nominal, regulated or unregulated

As inherent resistance associated with cable length and signal receiver input may affect operation of the transmitter, Figure 3 shows some guidelines for loop power required.

FIGURE 3 - Loop Power Guidelines

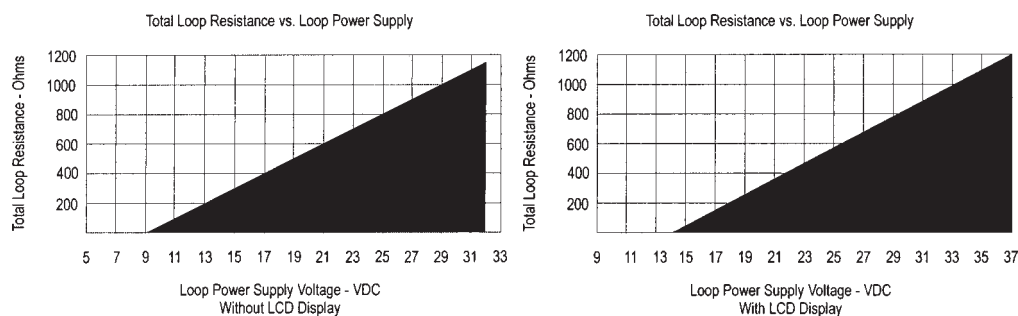

Please consult the Installation/Service Manual that was provided with your receiver for specific wiring instruction. Most Anderson receiver (displays, chart recorders, etc.) are capable of supplying loop power. Typical wiring would be as follows:

Figure 4 - Loop Diagram

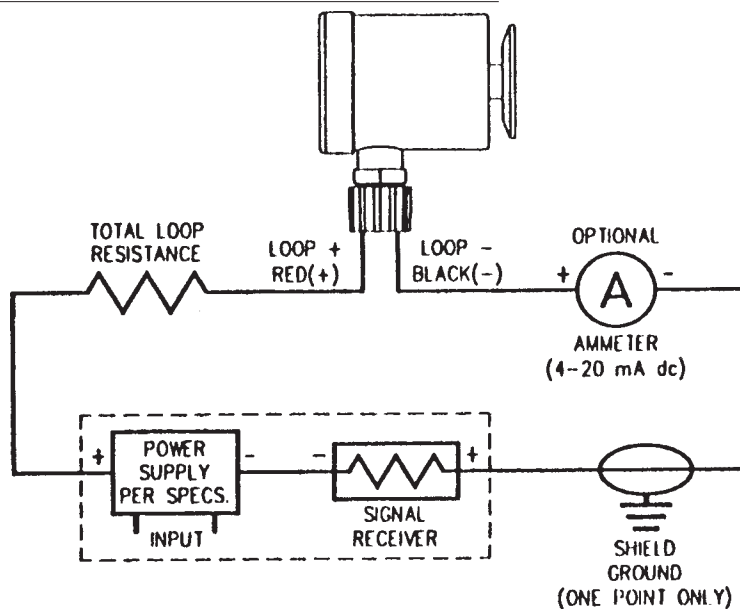

---

## **Section 6 - Liquid Crystal Display**

The RSP transmitter is available from the factory, or field upgradeable, with an integral LCD process display. The display is supplied from the factory pre-calibrated to the specified parameters.

NOTE: Although re-calibration may be performed, no alteration to the decimal point location may be made - this is a factory set function.

---

### **6.1 LCD INSTALLATION**

Installation of an LCD Process Display into an already existing RSP transmitter is as follows:

1. To prevent possible damage to the transmitter or receiver, it is recommended that all power be disconnected before proceeding.
2. Remove the conduit cap from the sensor. If upgrading a RSP in the field, you will be supplied with a new conduit cap (hole in center).
3. To the left of the wiring terminal block will be a small YELLOW wire loop. It has an arrow pointing to it stating "WITH DISPLAY CUT". Cut this loop, making sure the two ends don't come in contact with each other or anything else.
4. Insert the LCD RED wire into the (DISP +) terminal and tighten.
5. Insert the LCD BLACK wire into the (DISP -) terminal and tighten.
6. Slide the LCD display into the end of the conduit housing, orienting for proper position.
7. Secure the new cap provided.
8. Apply power to the system.,
9. At this point, check to be sure you are getting a proper reading. If the display is not active, immediately power down the loop and check your connections. If you feel the display is not reading properly, it may be necessary to perform calibration to the transmitter. Refer to Section 8 - Calibration.

---

## **Section 7 - Maintenance**

Anderson electronic sensors require very little maintenance, if any. We suggest that the sensor be inspected at 6 month intervals to ensure that they are not being physically abused, moisture is not entering the housing, and that the wiring is sound.



## Section 8 - Calibration

If you feel that the output of the RSP transmitter is not correct, calibration of the unit may be required. Section 8.1 illustrates the proper procedures for calibration of the transmitter, with section 8.2 covering calibration of the LCD display.

Equipment required:

- Pressure source
- Accurate reference gauge
- DC Milliamp Meter (accurate to .01 mA)
- Small straight blade screwdriver
- Calculator
- mA Signal generator (helpful for LCD calibration)

### 8.1 CALIBRATION - TRANSMITTER

Adjustments to the transmitter are made via the "ZERO" and "SPAN" potentiometers. These two adjustments are non-interactive, meaning changing the zero will not change the span. As general maintenance to the unit, a zero check is recommended at approximately 6 month intervals. If your unit is calibrated at a compound range, you will not see 4.00 mA at atmospheric zero. As reference, you may use the following chart to determine if your unit may require calibration (most common ranges are shown).

Sensor Range	Sensor Reads at Atmospheric Zero
0-psig - Positive Pressure	4.00 mA
0 psig - 30" Hg	4.00 mA
30" Hg - 15 psig	11.92 mA
30" Hg - 30 psig	9.26 mA
30" Hg - 60 psig	7.15 mA
30" Hg - 100 psig	6.05 mA

The output of a properly calibrated transmitter may be calculated by using the following formula:

$$\text{mA Output} = 16 \times \frac{(\text{KNOWN VALUE} - \text{LOW END OF RANGE})}{\text{TRANSMITTER SPAN}} + 4$$

*NOTE: The transmitter should be wired in a complete loop at this point, or on a test bench and configured per the diagram shown in Figure 4, page 7. Although no interaction between zero and span occurs, when making adjustments you should be as close to the top and bottom transmitter range as possible. This will ensure the best possible linearity in the final signal output.*

1. Expose the transmitter to a known zero reference point. If transmitter range starts at atmospheric zero, zero adjust at atmospheric zero. If transmitter is a compound range, you should be as close to sensor zero as possible. You must calculate the expected mA signal (use formula proved at start of this section).
2. Remove cap from transmitter.
3. With your meter set to DC mA, connect the RED (Meter +) lead to the (DISP +) terminal. Connect the BLACK (Meter -) lead to the (DISP -) terminal.
4. DO NOT USE THE LCD TO MAKE INITIAL SENSOR ADJUSTMENTS. If the LCD is not in calibration, an error will result in the calibration of the transmitter. The LCD should be calibrated separately. See Section 8.2, page 10 for proper procedures.
5. Adjust the transmitter ZERO potentiometer as shown in Figure 2, page 6, until you either

see 4.00 mA if you are at atmospheric zero, or your expected mA signal for a compound range.

6. Expose the transmitter to a know process variable near the top end of the range.
7. Again, using the formula provided, calculate the mA reading expected.
8. Adjust the transmitter SPAN potentiometer, as shown in Figure 2, page 6, until you see your expected mA output.

*NOTE: For pressure transmitters with compound ranges, the ranges must first be converted to all one type unit of measure. For example, a 30" Hg - 0-30 psig unit may be considered to have a range of -14.7 psig - 0-30 psig and a span of 44.7 psig (2.036" Hg = 1 psi). Be careful not to lose the (-) sign while performing the calculation of the proper reading.*

## 8.2 CALIBRATION OF LCD DISPLAY

*NOTE: Be sure the transmitter is in calibration before attempting to adjust the LCD display. The LCD reading is based on mA output from the transmitter. Therefore, if the transmitter is out of calibration, this error will be reflected in the LCD reading.*

To perform calibration of the LCD display, you must first determine the Zero and Span. This information is on a sticker located on the back of the display. Adjustments are made via Zero and Span potentiometers, see Figure 5 for location. You may use either the RSP transmitter itself to perform calibration of the display, or a 4-20 mA signal simulator.

**Figure 5 - LCD Display Calibration Adjustments**

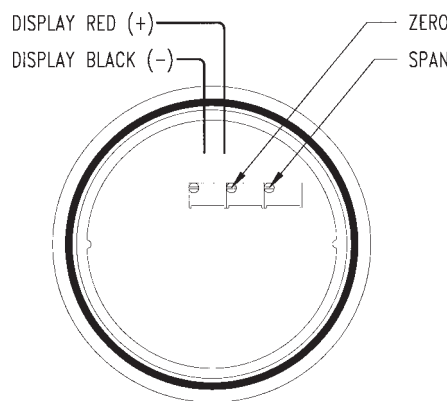

### CALIBRATION OF LCD USING 4-20 mA Simulator

1. Disconnect the LCD display from the transmitter by removing the RED and BLACK wires from their respective terminals.
2. Attach the POSITIVE lead of the simulator to the RED lead of the LCD display, and the NEGATIVE lead of the simulator to the BLACK lead of the LCD display.
3. The simulator should be set to POWERED output mode so that loop power is supplied. If your simulator is not capable of this function, wire to 9 VDC batteries in series with the 4-20 mA simulator and the LCD display.
4. Apply 4.00 mA to the LCD display.
5. Adjust the ZERO potentiometer until the LCD matches the range indicated on the sticker in the spot labeled ZERO CALIBRATION.

6. Apply 20.00 mA to the LCD display.
7. Adjust the SPAN potentiometer until the LCD matches the range indicated on the sticker in the spot labeled SPAN CALIBRATION.
8. The LCD display is now properly calibrated. Re-wire the transmitter at this time.

CALIBRATION OF LCD USING TRANSMITTER/PROCESS

1. To complete this calibration, you must have a pressure source and a known accurate reference. At this point you MUST be certain that the transmitter is in proper calibration. If necessary, start with section 8.1 - Transmitter Calibration, page 9.
2. Expose the transmitter to a known pressure near the LOW end of the calibrated range.
3. Adjust the potentiometer on the back of the LCD display labeled ZERO until the display matches your known reference
4. Expose the transmitter to a known pressure near the HIGH end of the calibrated range.
5. Adjust the potentiometer on the back of the LCD display labeled SPAN until the display matches your known reference
6. The LCD display is now properly calibrated.

---

## **Section 9 - Troubleshooting**

---

### **9.1 VOLTAGE CHECK**

Using a digital multimeter on the DC volts scale and with the sensor connected to the receiver, confirm that the sensor is being provided the correct loop power. Place the RED (Meter +) lead on the (Loop +) terminal, and the BLACK (Meter -) lead on the (Loop -) terminal. You should see between 9-32 VDC for a standard transmitter, and between 14-37 VDC if you have an optional LCD display installed.

---

### **9.2 CURRENT CHECK**

To check the mA loop, be sure the sensor is connected to the receiver. Open the cap on the transmitter to expose the wiring terminals. Using a digital multimeter on the mADC scale, connect the RED (Meter +) lead to the (DISP +) terminal and the BLACK (Meter -) lead to the (DISP -) terminal. You will be reading the mA current loop. A high current flow, approaching 30 mA, indicates a problem with the transmitter (internal source). If no current flow is observed this indicates either an open loop or a problem with the transmitter. To check a transmitter at a know pressure, refer to the Calibration section for information on how to properly calculate the mA output at the known value.

---

### **9.3 MISCELLANEOUS TROUBLESHOOTING**

Symptom	Action
No display on receiver	<ul style="list-style-type: none"> <li>• Check loop for broken wire</li> <li>• Check receiver for power out (loop power)</li> </ul>
Display on receiver reading improperly	<ul style="list-style-type: none"> <li>• Perform calibration check on RSP</li> <li>• Perform calibration check on signal receiver</li> </ul>
Transmitter not operating after LCD removed	<ul style="list-style-type: none"> <li>• Place a wire jumper from (DISP +) terminal to (DISP -) terminal</li> </ul>
When testing Loop, NO current flow detected	<ul style="list-style-type: none"> <li>• Check for broken connections</li> <li>• Check loop wiring (incorrect polarity affects loop)</li> </ul>

Feel free to contact Anderson Technical Services Department at 1-800-833-0081 for further assistance with troubleshooting.

---

## **Section 10 - Warranty and Return Statement**

These products are sold by The Anderson Instrument Company (Anderson) under the warranties set forth in the following paragraphs. Such warranties are extended only with respect to a purchase of these products, as new merchandise, directly from Anderson or from an Anderson distributor, representative or reseller, and are extended only to the first buyer thereof who purchases them other than for the purpose of resale.

### ***Warranty***

These products are warranted to be free from functional defects in materials and workmanship at the time the products leave the Anderson factory and to conform at that time to the specifications set forth in the relevant Anderson instruction manual or manuals, sheet or sheets, for such products for a period of one year.

**THERE ARE NO EXPRESSED OR IMPLIED WARRANTIES WHICH EXTEND BEYOND THE WARRANTIES HEREIN AND ABOVE SET FORTH. ANDERSON MAKES NO WARRANTY OF MERCHANTABILITY OR FITNESS FOR A PARTICULAR PURPOSE WITH RESPECT TO THE PRODUCTS.**

### ***Limitations***

Anderson shall not be liable for any incidental damages, consequential damages, special damages, or any other damages, costs or expenses excepting only the cost or expense of repair or replacement as described above.

Products must be installed and maintained in accordance with Anderson instructions. Users are responsible for the suitability of the products to their application. There is no warranty against damage resulting from corrosion, misapplication, improper specifications or other operating condition beyond our control. Claims against carriers for damage in transit must be filed by the buyer.

This warranty is void if the purchaser uses non-factory approved replacement parts and supplies or if the purchaser attempts to repair the product themselves or through a third party without Anderson authorization.

### ***Returns***

Anderson's sole and exclusive obligation and buyer's sole and exclusive remedy under the above warranty is limited to repairing or replacing (at Anderson's option), free of charge, the products which are reported in writing to Anderson at its main office indicated below.

Anderson is to be advised of return requests during normal business hours and such returns are to include a statement of the observed deficiency. The buyer shall prepay shipping charges for products returned and Anderson or its representative shall pay for the return of the products to the buyer.

Approved returns should be sent to:           ANDERSON INSTRUMENT COMPANY INC.  
156 AURIESVILLE ROAD  
FULTONVILLE, NY 12072 USA

ATT: REPAIR DEPARTMENT

# Notes

# Notes



**ANDERSON-NEGELE**

ANDERSON INSTRUMENT CO., INC • 156 AURIESVILLE RD. • FULTONVILLE, NY 12072 • USA • 800-833-0081 • FAX 518-922-8997  
ANDERSON INSTRUMENT CO. LP • 400 BRITANNIA RD. EAST, UNIT 1 • MISSISSAUGA, ONTARIO L4Z 1X9 • CANADA • 905-568-1440 • FAX 905-568-1652  
NEGELE MESSTECHNIK GmbH (A Division of Anderson) • RAIFFEISENWEG 7 • D-87743 EGG A. D. GÜNZ • GERMANY • +49 (0) 8333/9204-0 • FAX +49 (0) 8333/9204-49

[www.anderson-negele.com](http://www.anderson-negele.com)