



RODEM[®]
PROCESS EQUIPMENT
www.rodem.com 800-543-7312

STERILE AIR

Process Filtration



PROCESS FILTRATION

For over 35 years, Donaldson Process Filtration has provided quality sterile air, culinary steam, and liquid filtration products to process industries around the world. Donaldson innovative filter designs focus on energy efficient operation at high flow rates and are available in a wide variety of materials, micron ratings, and end styles to meet your specific requirements. From pre-filtration to final, and from low capacity to high, when you think purity, think Donaldson.

ABOUT STERILE AIR & GAS

In addition to contaminants such as dust, pollen, water or oil aerosols, and hydrocarbon or other vapors, compressed air can contain bacteria with the potential to spoil product or otherwise cause harm. Sanitary applications in the food, beverage, pharmaceutical, biopharmaceutical, and electronics industries require compressed air that is free of all of the above contaminants. Sterile air filtration products of the highest quality are required to meet the rigid purity specifications for the following:

Carbon Dioxide (CO₂)/Nitrogen

Not only is sterile compressed air required, but many applications in the food, beverage and other industries require certain gases to be filtered to a sterile condition. Examples include carbonation of beverages and nitrogen blanketing of produce packaging.

Tank Ventilation

Storage tanks often contain product that must be shielded from bacterial contamination. As the tanks are alternately filled and drained of their contents, atmospheric air either leaves or enters the head space in the tank. Since atmospheric air contains bacteria, this ventilation air must be filtered when it enters the tank. Sterile tank vent filters will allow air to enter the tank bacteria and particle free.

INDUSTRIES

- Food & Beverage
- Pharmaceutical
- Biopharmaceutical
- Biotechnology
- Electronics/Semiconductor
- Health Care

APPLICATIONS

- PET bottle blowing
- Blanketing/tank pressurization
- Sparge air used in whipped products
- Aseptic processing
- Aseptic packaging
- Incubation tanks
- Maturation tanks
- Motive force to move ingredients
- Tank ventilation



STERILE VS. SANITARY

The terms sterile and sanitary are sometimes used synonymously, but they do have different meanings.

- In process filtration applications, sterile means “free from live bacteria or other microorganisms.” For example, Donaldson P-SRF V sterile air filter elements are used to produce air that is free of bacteria.
- Sanitary, on the other hand, has a somewhat broader meaning. The term relates to health or the protection of health and means “free from elements such as filth or pathogens that endanger health.” Something that is sanitary is characterized by or readily kept in cleanliness. For example, Donaldson 3A certified PG-EG sanitary grade filter housings are designed to be easily kept in a state of cleanliness, allowing them to be free of the filth or pathogens that can endanger health.

In summary, sterile is a condition while sanitary is a characteristic.

HOW BIG IS BACTERIA?

In general, bacteria range in size from 0.2 micron to 30 micron.

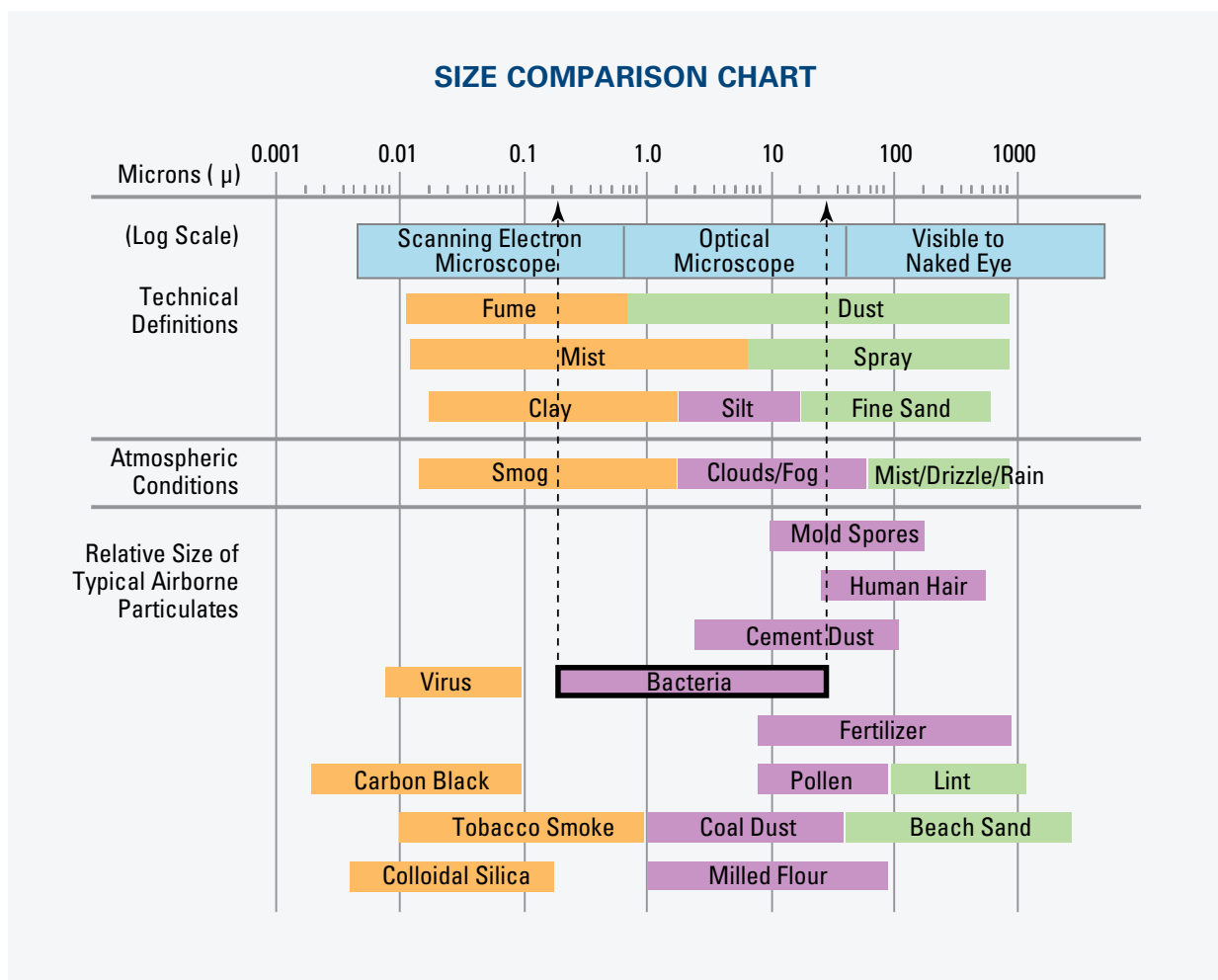

HOW TO MAKE STERILE AIR

The primary purpose of the sterile filter element is to filter out bacteria; therefore, it should be adequately protected with upstream prefiltration to assure its long-term efficiency and effectiveness. As seen in the figure below, a typical point-of-use sterile air filter train consists of:

- A P highly porous sintered polyethylene particulate filter element (25 µm)
- A S polyester microfiber fleece fine coalescing filter element (99.99998% efficiency at 0.01 µm)
- An A activated carbon hydrocarbon vapor filter element (<0.003 PPM residual oil content)
- A P-SRF V sterile air final filter element (99.9999998% efficiency at 0.02 µm)

STERILE AIR

Installation with variable compressed air demand

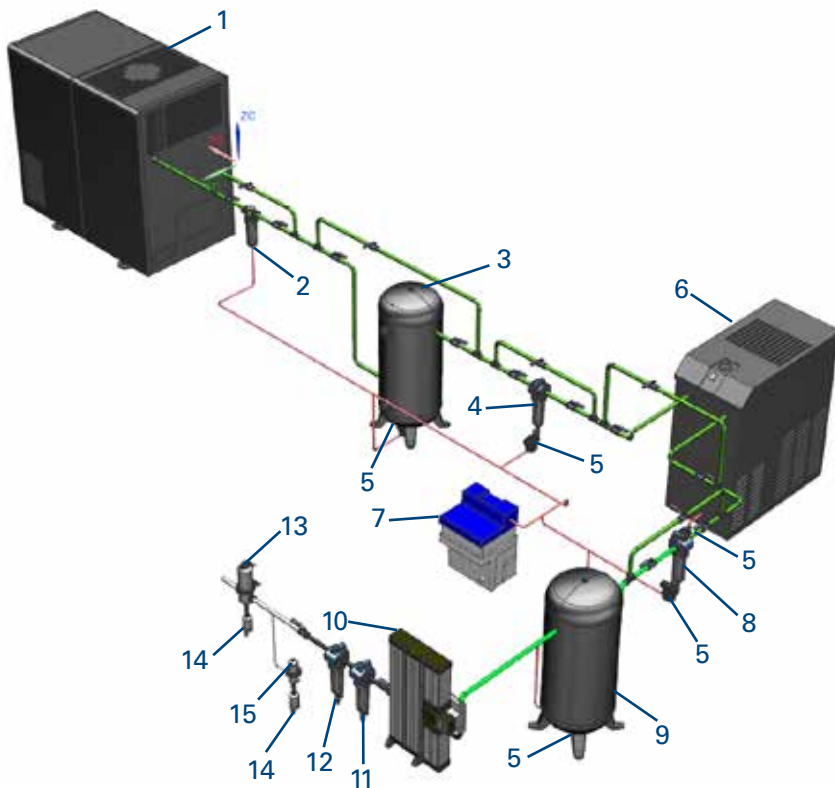

No.	Description
1	Air Compressor with Aftercooler
2	DF-C Cyclone Separator
3	Wet Storage Tank
4	DF Filter with V-Grade Coalescing Filter
5	UFM-D Zero-Loss Condensate Drain
6	Refrigerated Dryer
7	DS Oil/Water Separator
8	DF Filter with M-Grade Coalescing Filter
9	Dry Storage Tank
10	Ultrapac 2000 Dryer
11	DF Filter with S-Grade Particulate Filter
12	DF Filter with A-Grade Carbon Adsorption Filter
13	PG-EG Sanitary Housing with P-SRF V Sterile Filter
14	Condensate Drain
15	P-EG Housing with P-GS 5 µm Steam Filter

STERILIZATION-IN-PLACE (SIP)

In addition to prefiltration to protect the final sterile filter element and improve the overall quality of the sterile air itself, the P-SRF V filter element and PG-EG housing must be routinely sterilized according to application requirements. Captured bacteria can colonize the outer surface of the filter media and begin to migrate through. As shown in the figure above, the P-SRF V/PG-EG filter element assembly can be sterilized in place with steam. The steam itself is filtered through the P-GS sintered stainless steel element in a P-EG housing.

AUTOClave STERILIZATION

If SIP is not in use, filter elements can be sterilized outside of the system in an autoclave according to published procedures.

STERILIZATION PROCEDURES

P-SRF and P-SRF V sterile air filter elements can be sterilized using one of two procedures: 1) sterilize-in-place (SIP) or 2) autoclave. Both elements can withstand up to 100 sterilization cycles without loss of integrity. Cycle times and temperatures for both procedures are:

Temperature	Cycle Times (minutes)			
	Sterilization	Cooling	Reheating	Total
250-255°F	30	15	15	60
265-275°F	15	15	15	45
285°F	10	15	15	40

STERILIZE IN PLACE (SIP) PROCEDURE

- With SIP, the filter element and housing remain in place and steam is used to sterilize the filtration system without the need for disassembly.
- The steam used for SIP must be filtered of rust and other particles.
- Steam pressure must not be allowed to fall below 15 psig throughout the SIP process.
- Condensate must be drained from the system during sterilization.
- Any air trapped in the housing must be vented.
- Upstream and downstream Δp gauges must be used to assure differential pressure across the filter does not exceed 5 psid during SIP.
- After sterilization, pressurize the system with process air or gas up to the steam pressure used and allow the system to cool until ready for use.
- Always use the lowest possible sterilization temperature to avoid unnecessary stress on the filter element.

CULINARY STEAM

Installation with variable compressed air demand

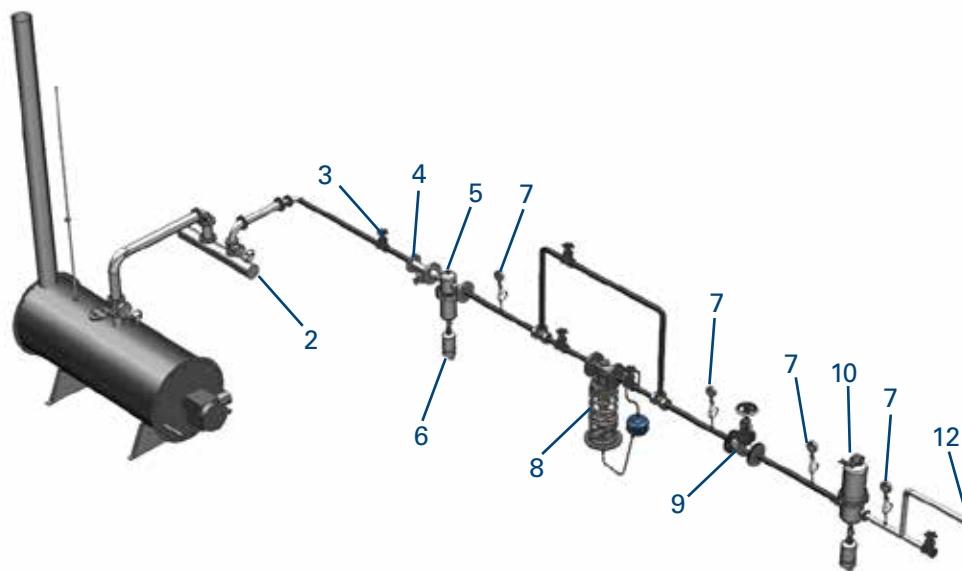

No.	Description
1	Boiler
2	Steam Header
3	Stop Valve
4	Strainer
5	Entrainment Separator (P-EG housing with 25 µm P-GSLN element)
6	Condensate Trap
7	Pressure Gauge
8	Pressure Reducing Valve
9	Steam Throttling Valve
10	Culinary Steam Filter (PG-EG housing with 5 µm P-GS element)
11	Sampling Valve
12	Sanitary Check Valve and Tubing to Process

AUTOClave

- Generally, only the filter element is sterilized in an autoclave, but both the housing and element can be sterilized if removed from the process, disassembled and put in the autoclave.
- In addition to the cycle times given on the previous page, follow the specific procedures provided with the autoclave in use.

P-SRF V – MICROFIBER

Donaldson P-SRF V is the next generation of sterile air filtration. The pleated depth media matrix is specifically designed to offer a lower pressure drop and improved retention capability, which minimize machine downtime and cost of ownership. The revolutionary media configuration offers improved hydrophobic capabilities for an especially fast de-wetting time. You won't find a better sterile air filter on the market today.

- 99.9999998% efficient at 0.02 μm
- Binder-free borosilicate media with enhanced PTFE layer
- Stainless steel end caps and support cores
- 100% integrity tested at factory
- 100% integrity tested at factory
- Meets U.S. FDA, CFR Title 21 and 1935/2004/EC requirements for food and beverage contact
- Can be repeatedly sterilized in-line with steam or in an autoclave
- Recommended with PG-IL, PG-EG, P-EG, and P-BE housings



P-SRF X – PTFE MEMBRANE

Donaldson P-SRF X elements utilize PTFE membrane media in a stainless steel cage to provide superior filtration in extreme process conditions. It can withstand over 250 steam sterilization cycles and normal working temperatures up to 392°F.

- Absolute particulate retention rates at 0.2 μm
- Highly porous, hydrophobic, PTFE membrane media for high flow rates and high retention of particles
- Stainless steel end caps and support cores
- Contains no binders or adhesives
- 100% integrity tested at factory
- Meets U.S. FDA, CFR Title 21 and 1935/2004/EC requirements for food and beverage
- Can be repeatedly sterilized in-line with steam or in an autoclave
- Recommended with PG-IL, PG-EG, P-EG, and P-BE housings



PT N – PTFE MEMBRANE

Donaldson PT N filters utilize membrane media for use in harsh filtration applications such as highly acidic or alkali solutions.

- Absolute particulate retention rates at 0.2 μm
- Highly porous, hydrophobic, PTFE membrane media for high flow rates and high retention of particles
- Polypropylene end caps and support cores
- Contains no binders or adhesives
- 100% integrity tested at factory
- Meets U.S. FDA, CFR Title 21 and 1935/2004/EC requirements for food and beverage contact
- Can be repeatedly sterilized in-line with steam or in autoclave
- Recommended with P-EG, PG-EG and P-BE housings



P-EG GAS & STEAM FILTER HOUSING

An economical solution when filtering air, gases or steam.

- Available in 304 or 316L stainless steel
- 18 sizes in flow capacities from 35 to 13,000 scfm
- Low differential pressure at high flow rates
- Inner surface:
 - Models 0006 – 0288, pickled and passivated Ra 63
 - Models 0432 – 1920, bead blast
- Outer surface finish:
 - Models 0006 – 0288, pickled, passivated and polished Ra 63
 - Models 0432 – 1920, bead blast
- NPT & ANSI connections (alternative connections available upon request)



PG-EG SANITARY GAS & STEAM FILTER HOUSING

The PG-EG sanitary filter housing is designed for the purification of compressed air or technical gases in sanitary and hygienic applications.

- 3-A certification for models 0006 - 0192
- Available in 304 or 316L stainless steel
- 12 sizes in flow capacities from 35 to 13,000 scfm
- Low differential pressure at high flow rates
- Inner & Outer Surface:
 - Models 0006 – 0192 Electropolished to Ra 32
 - Models 0432 – 1920 Nitric passivated Ra 32
- Connections:
 - Models 0006 – 0192 Tri-Clamp (alternate connections available upon request)
 - Models 0432 – 1920 ANSI flange connection



P-BE VENT FILTER HOUSING

The P-BE filter is designed for venting of stationary or mobile storage tanks to atmosphere. The simple two-piece construction incorporates splash protection to prevent liquids from coming into contact with the filter medium. Sterile and non-sterile grade elements may be incorporated into this housing.

- Available in 304 or 316L stainless steel
- 12 sizes in flow capacities from 3 to 1,200 cfm at ambient pressure
- For sterile, low differential pressure at high flow rates when used with a P-SRF N sterile air filter element
- Will accommodate other filter elements with UF connection for chemical compatibility



PG-IL IN-LINE SANITARY GAS & LIQUID FILTER

The PG-IL in-line filter housing has been designed for the purification of liquids and gases in sanitary and hygienic applications.

- 3-A certified and BPE compliant
- Available in 304 or 316L stainless steel
- 4 sizes in liquid flow capacities from 3 to 18 gpm and sanitary gases from 215 to 1,290 scfm
- Inner surface electropolished to Ra 15 and outer surface to an Ra 32



SUPERIOR FILTRATION. MAXIMUM PROTECTION.

Extensive Product Portfolio

- Process air, steam and liquid filtration products
- Performance engineered to sanitary guidelines
- Wide range of filtration media for any application
- Housings, elements, and parts in-stock, ready to ship

Advanced Technology

- Optimized filtration performance and efficiency
- Extensive research and development capabilities
- Advanced design and testing capabilities
- Over 1,000 engineers and scientists worldwide

Unrivalled Support and Expertise

- Expert technical specialists available as resource
- Comprehensive pre- and post-sale support
- Extensive filter analysis and trouble-shooting
- 100 years of successful global manufacturing



Registered



Standard No. 10-04*



Member of



Member of



Member of



Member of



Important Notice

Many factors beyond the control of Donaldson can affect the use and performance of Donaldson products in a particular application, including the conditions under which the product is used. Since these factors are uniquely within the user's knowledge and control, it is essential the user evaluate the products to determine whether the product is fit for the particular purpose and suitable for the user's application. All products, product specifications, availability and data are subject to change without notice, and may vary by region or country.



Donaldson Company, Inc.
Process Filtration
Minneapolis, MN

donaldsonprocessfilters.com
shop.donaldson.com

North America 800-543-3634
Mexico 800-343-3639
Fax 952-885-4791

processfilters@donaldson.com

F117031 ENG (06/18) Sterile Air

© 2018 Donaldson Co., Inc. All Rights Reserved.

Donaldson and the color blue are marks of Donaldson Company, Inc.

All other marks belong to their respective owners.

{Contains Donaldson proprietary technology.}