



**RODEM**<sup>®</sup>

PROCESS EQUIPMENT

[www.rodem.com](http://www.rodem.com) 800-543-7312

Instruction Manual  
Plate Heat Exchangers

M15 TL10 T20 TS20  
MX25 M30 MA30 TL35

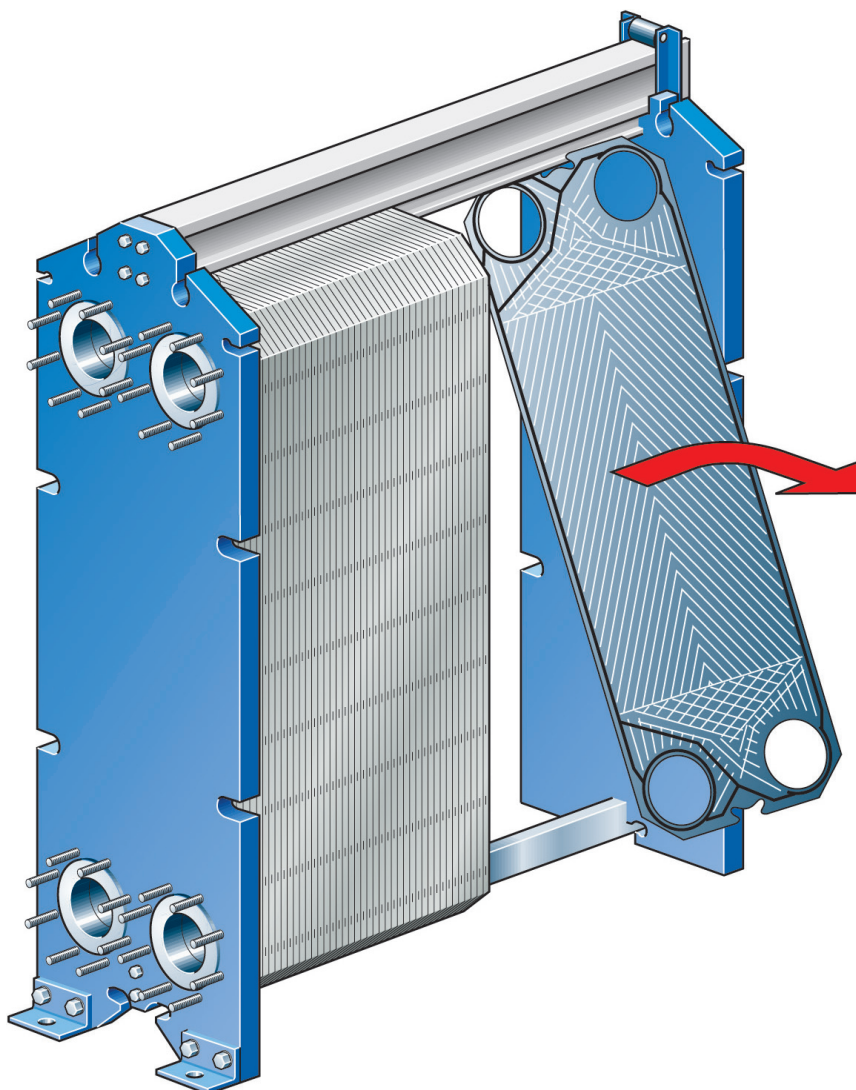

eng

ger

fre

spa

por

ita

swe

dan

fin

dut

rus

pol

nor

## Table of contents

<b>Description</b> .....	1
Main components .....	1
Function .....	2
<b>Installation</b> .....	3
Requirements .....	3
Lifting .....	4
Raising .....	5
<b>Operation</b> .....	6
Start-up .....	6
Unit in operation .....	7
Shut-down .....	7
<b>Maintenance</b> .....	8
Cleaning-In-Place (CIP) .....	8
Manual cleaning .....	9
Pressure test after maintenance.....	16
Regasketing .....	17

How to contact Alfa Laval:

Contact details for all countries are continually updated on our website.

Please visit [www.alfalaval.com](http://www.alfalaval.com) and contact your local Alfa Laval Representative.

Except for this Instruction Manual, the following documents are also included in this shipment:

- Plate Heat Exchanger (PHE) drawing
- Plate hanging list
- Parts list with exploded view drawing.



## Environmental compliance

AlfaLaval endeavours to perform its own operations as cleanly and efficiently as possible, and take environmental aspects into consideration when developing, designing, manufacturing, servicing and marketing its products.

### Unpacking

Packing material consists of wood, plastics, cardboard boxes and in some cases metal straps.

- Wood and cardboard boxes can be reused, recycled or used for energy recovery.
- Plastics should be recycled or burnt at a licensed waste incineration plant.
- Metal straps should be sent for material recycling.

### Maintenance

During maintenance oil and wear parts in the machine are replaced.

- All metal parts should be sent for material recycling.
- Worn out or defective electronic parts should be sent to a licensed handler for material recycling.
- Oil and all non metal wear parts must be taken care of in agreement with local regulations.

### Scrapping

At end of use, the equipment shall be recycled according to relevant, local regulations. Beside the equipment itself, any hazardous residues from the process liquid must be considered and dealt with in a proper manner. When i doubt, or in absence of local regulations, please contact the local AlfaLaval sales company.

## Description

### Main components

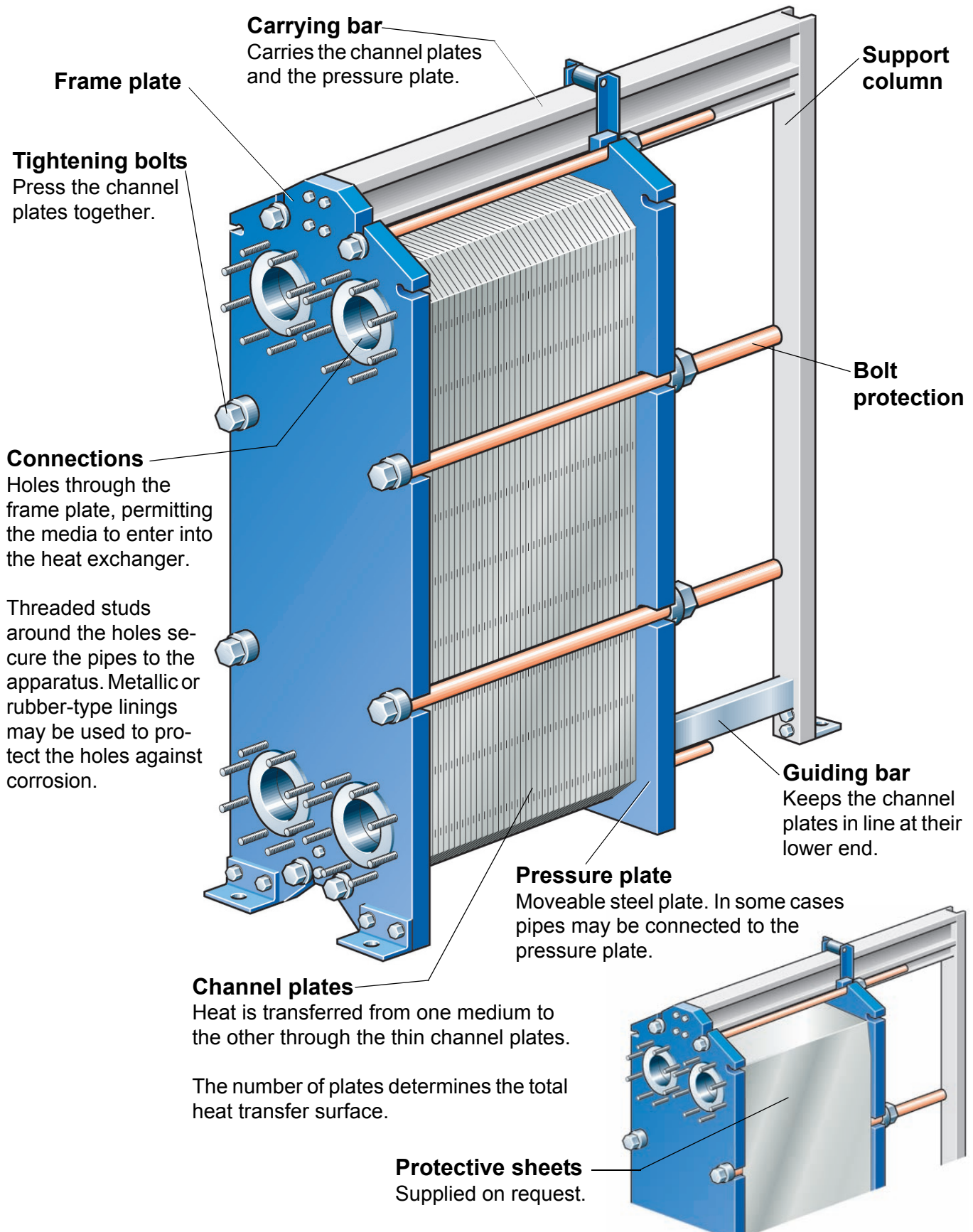



## Function

The plate heat exchanger consists of a pack of corrugated metal plates with portholes for the passage of the two fluids between which heat transfer will take place.

The plate pack is assembled between a frame plate and a pressure plate and compressed by

tightening bolts. The plates are fitted with a gasket which seals the channel and directs the fluids into alternate channels. The plate corrugation promotes fluid turbulence and supports the plates against differential pressure.

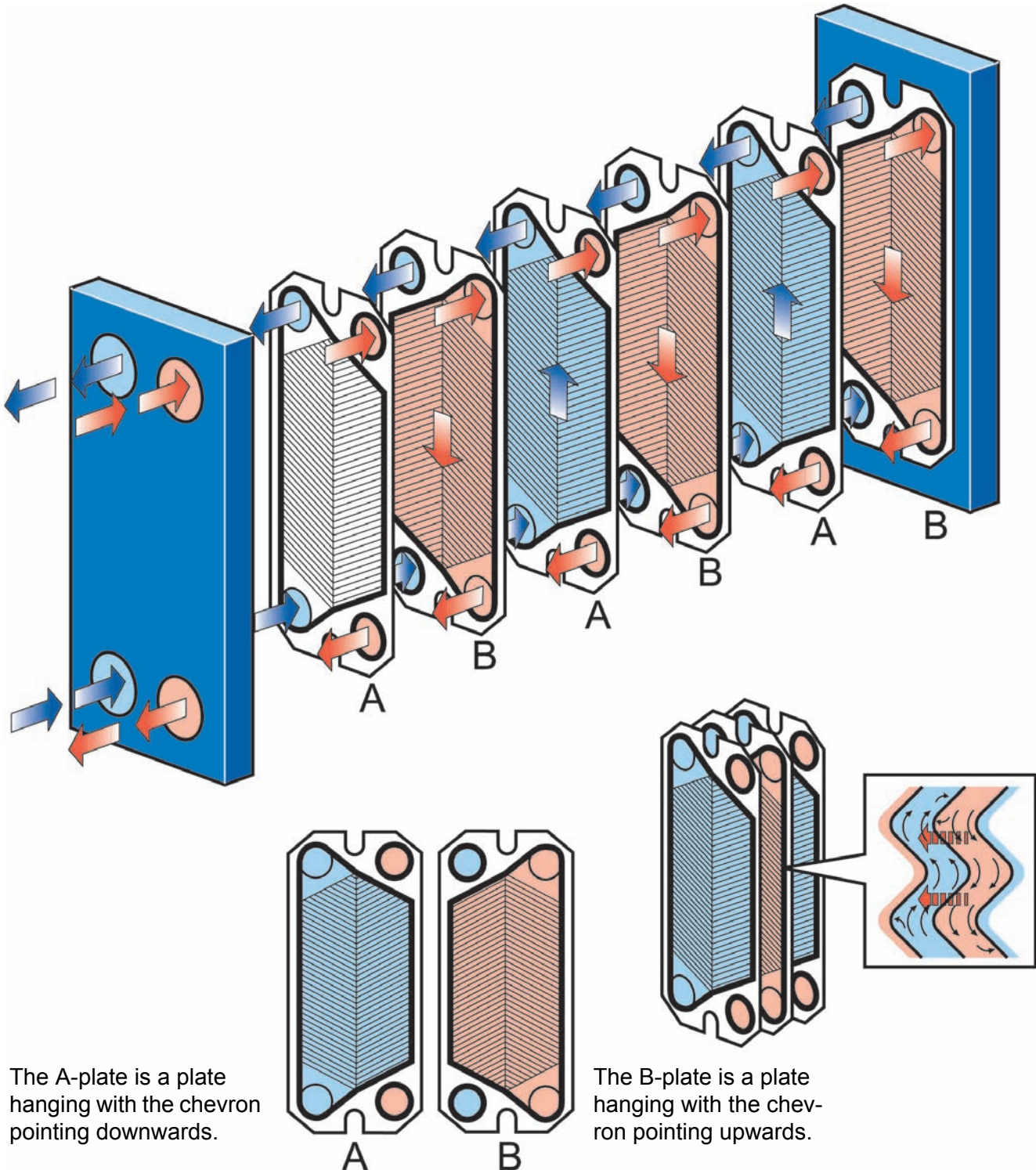

The A-plate is a plate hanging with the chevron pointing downwards.

The B-plate is a plate hanging with the chevron pointing upwards.

# Installation

## Requirements

eng

### Multi-pass units:

#### Connections on the pressure plate

It is important that the plate pack has been tightened to the correct measurement (check against drawing) before the pipe is connected.

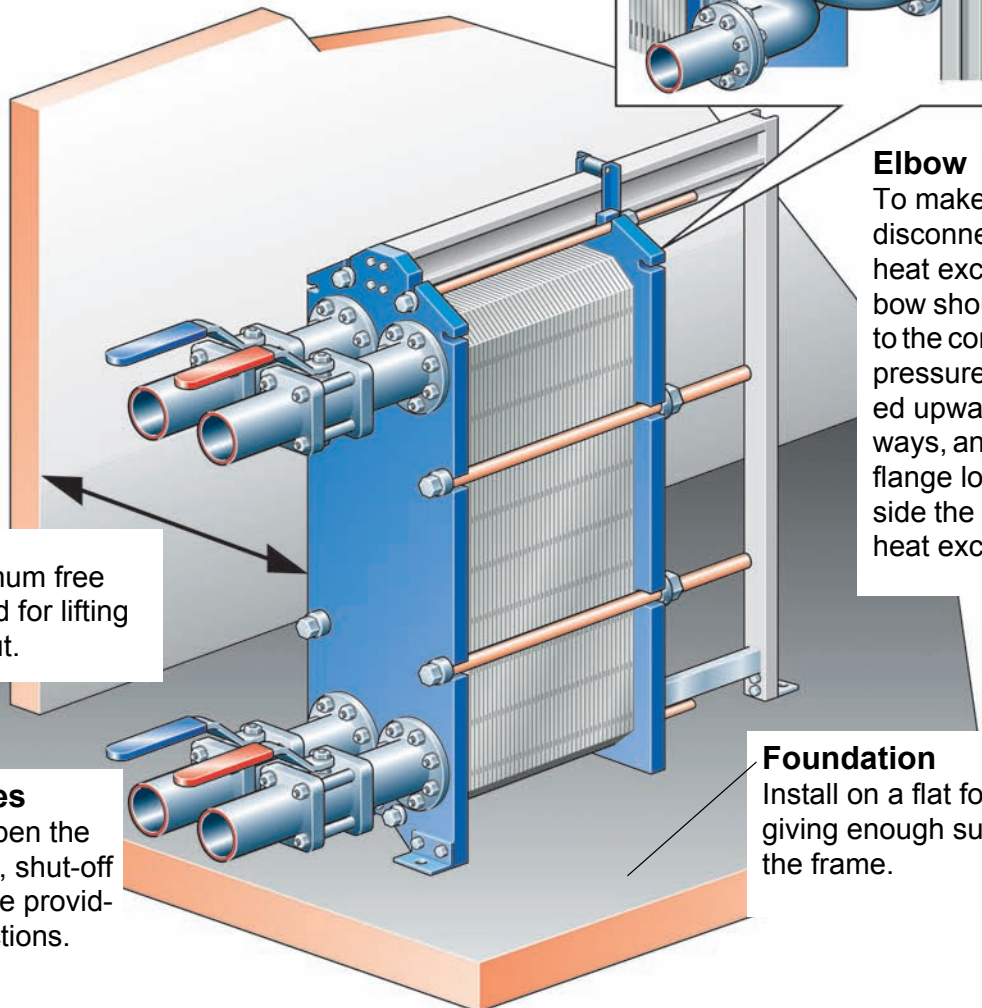
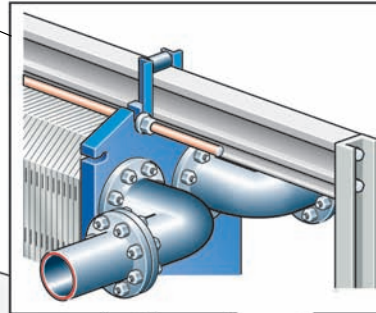

#### Elbow

To make it easier to disconnect the plate heat exchanger, an elbow should be flanged to the connection in the pressure plate, directed upwards or sideways, and with another flange located just outside the contour of the heat exchanger.

#### Space

1500 mm minimum free space is needed for lifting plates in and out.

#### Shut-off valves

To be able to open the heat exchanger, shut-off valves should be provided in all connections.

#### Foundation

Install on a flat foundation giving enough support to the frame.

### Note!

- Before connecting any piping, make sure all foreign objects have been rinsed out of the system.
- When connecting the pipe system make sure the pipes do not subject the plate heat exchanger to stress or strain.
- To avoid water hammer, do not use fast-closing valves.

Safety valves should be installed according to current pressure vessel regulations.

If PHE surface temperature is expected to be hot or cold, the PHE should be isolated.

It is recommended that protective sheets are used to cover the PHE.

For each model, design pressures and temperatures are marked on the identification plate. Those must not be exceeded.

## Lifting



### Warning!

Never lift by the connections or the studs around them. Straps should be used when lifting. Place straps according to picture.

M15, TL10, T20, TS20

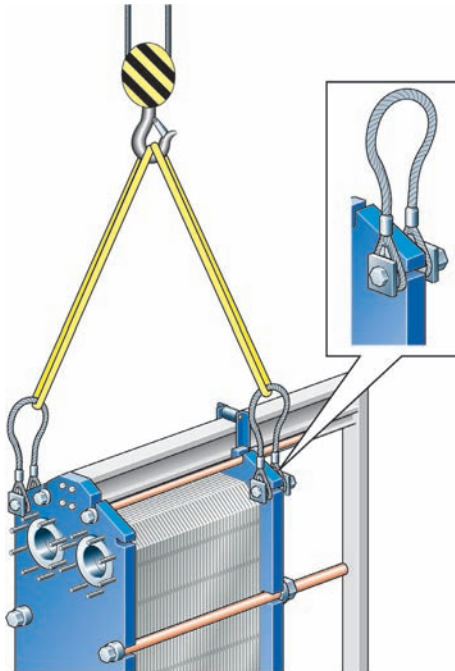

MX25, M30, MA30

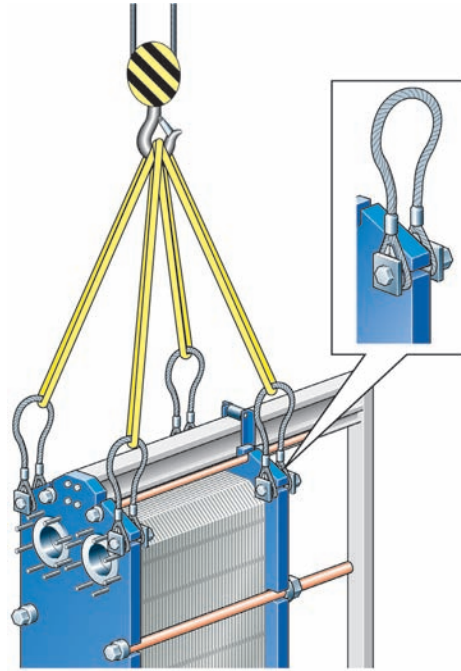

TL35

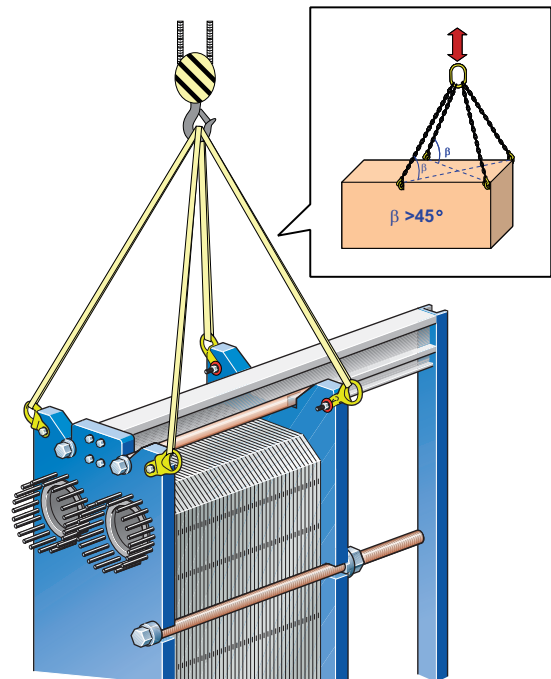



## Raising

- 1** Place two timber beams on the floor.

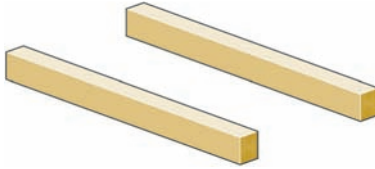

- 2** Lift the heat exchanger off pallet using e.g. straps.

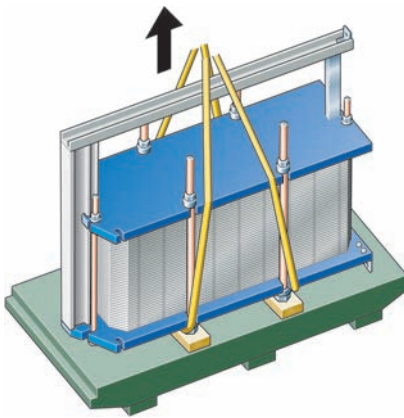

- 3** Place the heat exchanger on the timber beams.

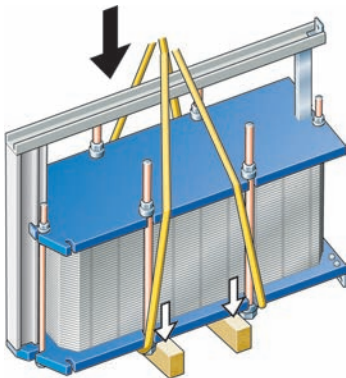

- 4** Place straps around one bolt on each side.

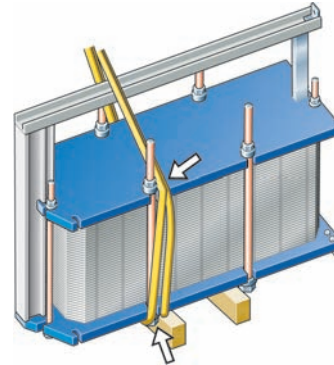

- 5** Lift the heat exchanger off the timber beams.

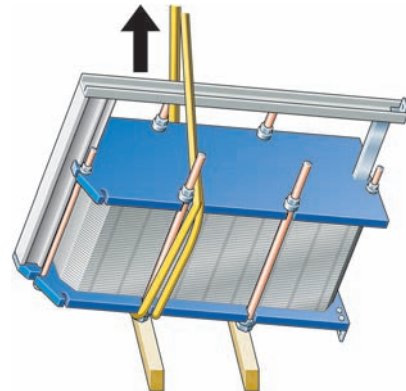

- 6** Lower the heat exchanger to horizontal position and place it on the floor.

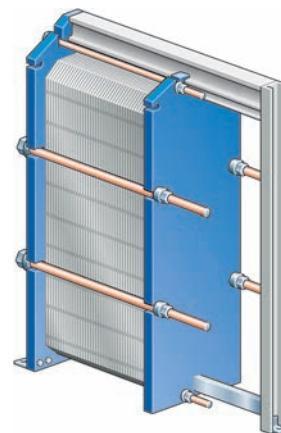



## Operation

### Start-up

#### Note!

If several pumps are included in the system, make sure you know which one should be activated first.

#### Note!

Adjustments of flowrates should be made slowly in order to avoid the risk of **water hammer**.

Water hammer is a shortlasting pressure peak that can appear during start-up or shut-down of a system, causing liquids to travel along a pipe as a wave at the speed of sound. This can cause considerable damage to the equipment.

1

Check that measurement A is correct. For A, see enclosed PHE-drawing.

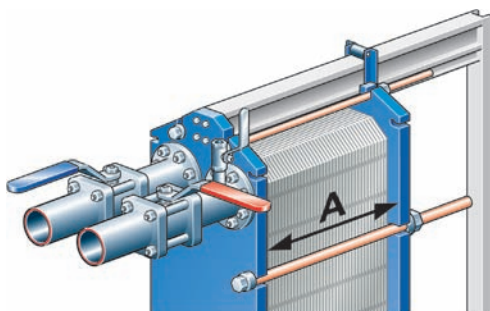

2

Check that the valve is closed between the pump and the unit controlling the system flowrate.

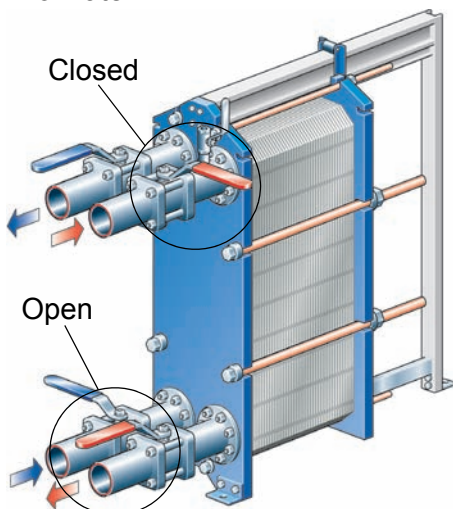

3

If there is a valve at the exit, make sure it is fully open.

4

Open the vent and start the pump.

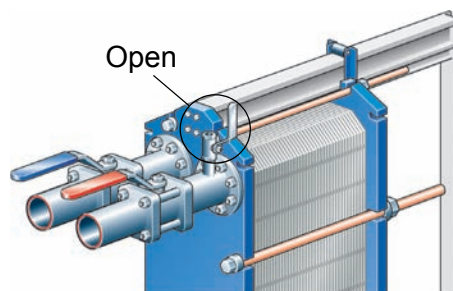

5

Open the valve slowly.

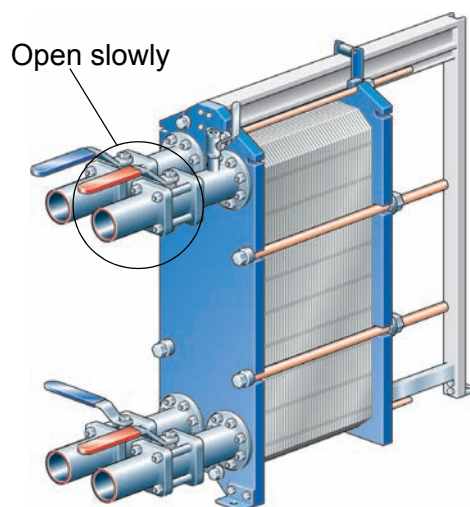

6

When all air is out, close the vent.

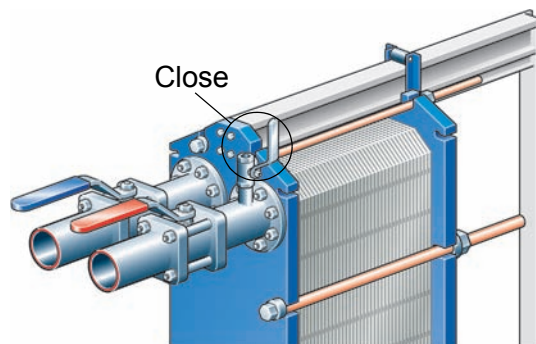

7

Repeat steps 1–6 for the second media.

## Unit in operation

### Note!

Adjustments of flowrates should be made slowly in order to protect the system against sudden and extreme variations of temperature and pressure.

During operation, check that

- media temperatures and pressures are within the limits stated on the PHE-drawing
- no leakages appear due to faulty tightening of the plate pack or to defective or damaged gaskets
- carrying bar and guiding bar are kept clean and greased
- the bolts are kept clean and greased.

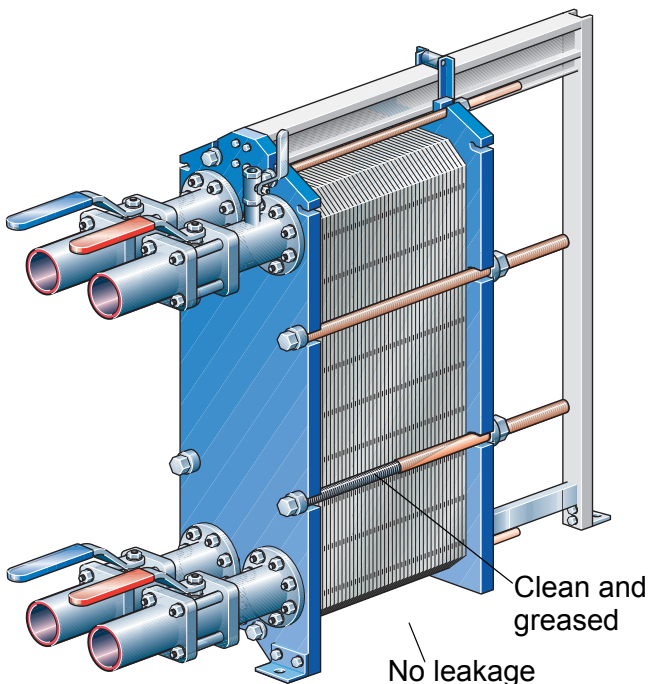

Always consult your local Alfa Laval office for advice on

- new plate pack dimensions if you intend to change number of plates
- selection of gasket material if operating temperatures and pressures are permanently changed, or if another medium is to be processed in the PHE.

## Shut-down

### Note!

If several pumps are included in the system, make sure you know which one should be stopped first.

- 1** Slowly close the valve controlling the flow-rate of the pump you are about to stop.

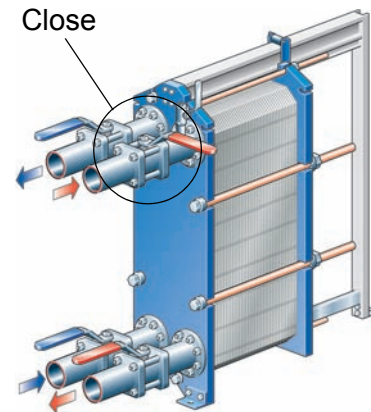

- 2** When the valve is closed, stop the pump.
- 3** Repeat steps 1–2 for the other side.

- 4** If the heat exchanger is shut down for several days or longer, it should be drained. Draining should also be done if the process is shut down and the ambient temperature is below freezing temperature of the media. Depending on the media processed, it is also recommended to rinse and dry it.

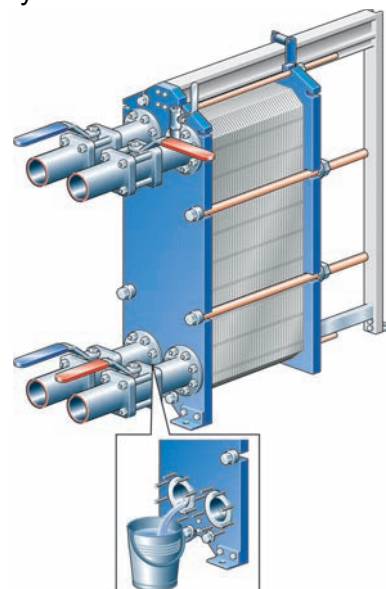

## Maintenance

### Cleaning-In-Place (CIP)

The Cleaning-In-Place (CIP) equipment permits cleaning of the plate heat exchanger without opening it.

If CIP cannot be done, cleaning must be performed manually, see section “Manual cleaning”

CIP performs

- cleaning of fouling and descaling of lime deposits
- passivation of cleaned surfaces to reduce susceptibility to corrosion
- neutralization of cleaning liquids before draining.

Follow the instructions of the CIP equipment.

The following CIP models can be used: CIP75, CIP200, CIP400 and CIP800.

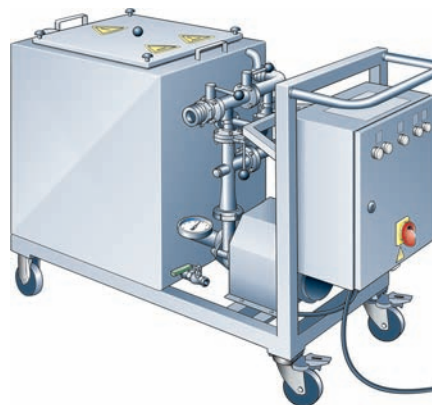

### Cleaning liquids

Cleaning liquid	Description
AlfaCaus	A strong alkaline liquid, for removing paint, fat, oil and biological deposits.
AlfaPhos	An acid cleaning liquid for removing metallic oxides, rust, lime and other inorganic scale.
AlfaPass	An alkaline liquid for passivation (inhibition of corrosion).
AlfaNeutra	A strong alkaline liquid for neutralization of AlfaPhos before drainage.
Alfa P-Scale	An acidic cleaning powder with a corrosion inhibitor particularly effective for removing of calcium carbonate and other inorganic scale.
Alfa P-Neutra	An alkaline powder for neutralization of used Alfa P-Scale prior to disposal.
AlfaAdd	A neutral cleaning strengthener to be used with AlfaPhos, AlfaCaus and Alfa P-Scale. Provides better cleaning results on oily, fatty surfaces and where biological growth occurs. AlfaAdd also reduces any foaming.
Alpacon Descalant	An acidic, water based, non-hazardous cleaning agent designed for removal of scale, magnetite, algae, humus, mussels, shellfish, lime and rust. Containing BIOGEN ACTIVE, a biological mixture made from renewable materials, as an active ingredient.
Alpacon Degreaser	A neutral degreaser to be used with Alpacon Descalant. Effectively removes oil, fat or grease layers, but also reduces foaming. Containing BIOGEN ACTIVE, a biological mixture made from renewable materials, as an active ingredient.

## Manual cleaning



### Warning!

To avoid hand injuries owing to sharp edges, protective gloves should always be worn when handling plates and protective sheets.

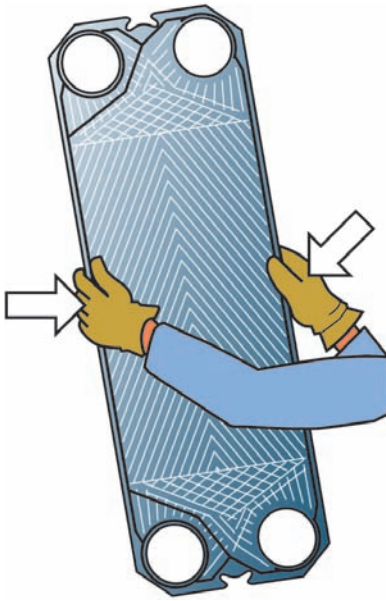

## Opening



### Warning!

If the heat exchanger is hot, wait until it has cooled down to about 40 °C (104 °F).

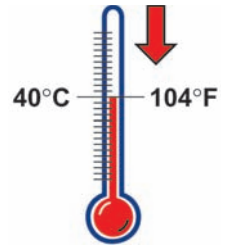

- 1 Drain the plate heat exchanger.

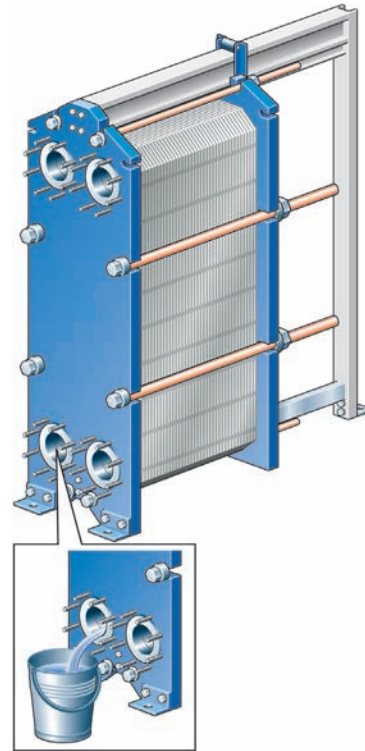

- 2 Inspect the sliding surfaces of the carrying bar and wipe clean.

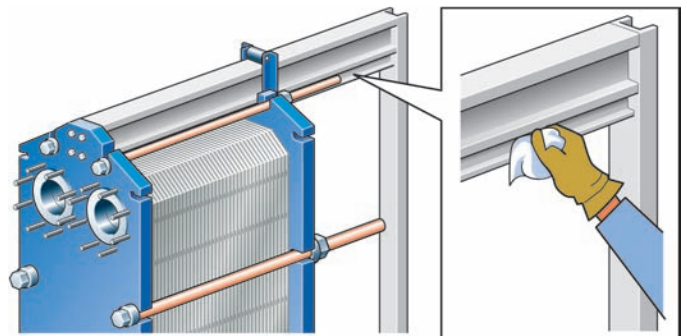





eng

**3** Mark the plate assembly on the outside by a diagonal line.

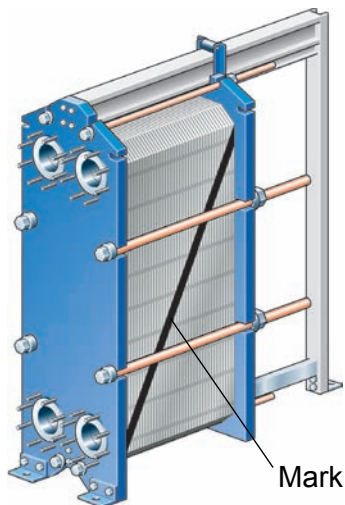

**4** Measure and note down the dimension A.

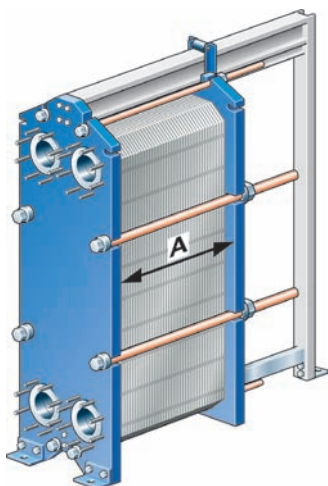

**5** Loosen the bolts which are not fitted with bearing boxes and remove them.

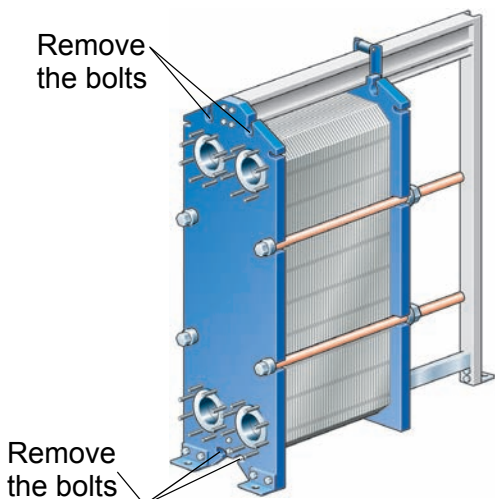

**6** The pairs of bolts that are fitted with bearing boxes are opened alternately and diagonally in two steps, see figures below.

Step	Bolt No.	To dimension
1	1-2-3-4	1,05A
2	1-2 or 3-4	Opening

Be careful so that the frame plate and pressure plate are always in parallel. Skewing of the pressure plate during opening must not exceed 10 mm (**2 turns per bolt**) across the width and 25 mm (**5 turns per bolt**) vertically.

Step 1: Loosen the four bolts alternately and diagonally until the plate package measures 1,05A.

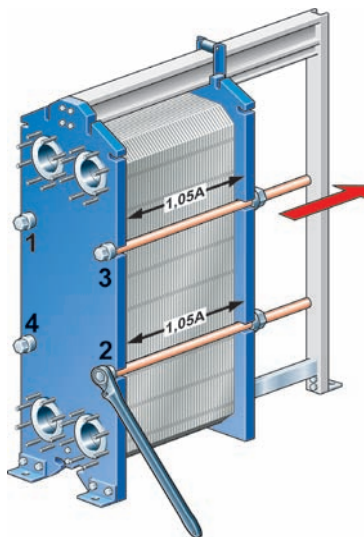

Step 2: Loosen the two diagonal pairs of bolts are loosened alternately, as shown in the figure below.

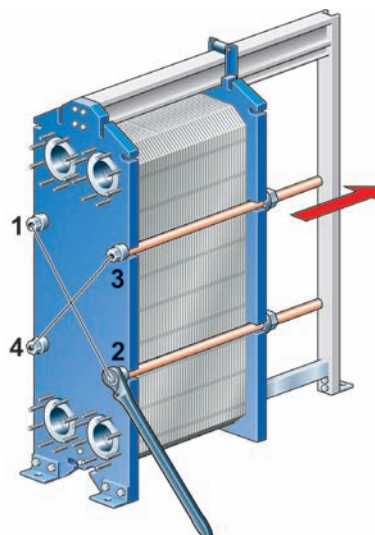

- 7** Open the plate pack by letting the pressure plate glide on the carrying bar.

If plates are to be numbered, do this before removing the plates.

Plates need not be removed if cleaning is done using only water, i.e. without cleaning agent.

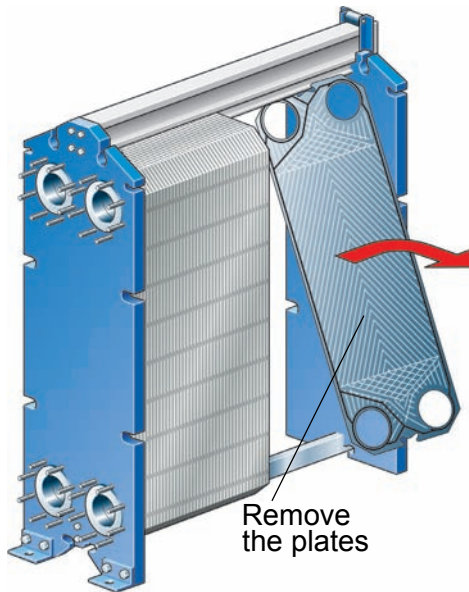

## Manual cleaning of opened units



### Caution!

Never use hydrochloric acid with stainless steel plates. Water of more than 330 ppm Cl may not be used for the preparation of cleaning solutions. It is very important that carrying bars and support columns in aluminium are protected against chemicals.

### Note!

Be careful not to damage the gasket during manual cleaning.

### Deposits removable with water and brush

Plates need not to be removed from the plate heat exchanger during cleaning.

- 1 Remove deposits using a soft brush and running water.

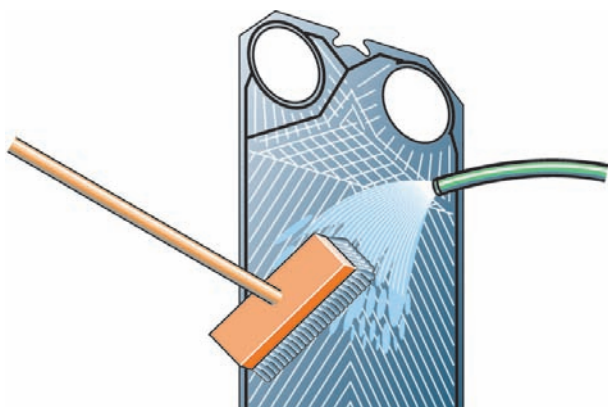

- 2 Rinse with water using a high pressure hose.



### Deposits not removable with water and brush

Plates must be removed from the plate heat exchanger during cleaning.

- 1 Brush with cleaning agent.



- 2 Rinse with water.



**Cleaning agents – Incrustation, scaling**  
**Concentration max 4 %**  
**Temperature max 60 °C (140 °F)**

Incrustation – Scaling	Sediment	Cleaning agent
Calcium carbonate	Corrosion products	Nitric acid
Calcium sulphate	Metal oxides	Sulfamic acid
Silicates	Silt	Citric acid
	Alumina	Phosphoric acid
	Diatomic organisms and their excrement of various colours	Complexing agents (EDTA, NTA) Sodium polyphosphates

**Cleaning agents – Biological growth, slime**  
**Concentration max 4 %**  
**Temperature max 80 °C (176 °F)**

Biological growth – Slime	Cleaning agent
Bacteria	Sodium hydroxide
Nematodes	Sodium carbonate
Protozoa	Cleaning effect can be considerably increased by the addition of small quantities of hypochlorite or agents for the formation of complexes and surfactants.

**Cleaning agents – Oil residues, asphalt, fats**

Deposit	Cleaning agent
Oil residues Asphalt Fats	Paraffinic naphta-based solvent (e.g. kerosine).  <b>Note!</b> Gaskets in EPDM rubber qualities swell in these media. Contact time should be limited to 30 minutes.



**Caution!**

The following solutions should not be used:

- Ketones (e.g. Acetone, Methylketone, Methylisobutylketone)
- Esters (e.g. Ethylacetate, Butylacetate)
- Halogenated hydrocarbons (e.g. Chloroethene, Carbon tetrachloride, Freons)
- Aromatics (e.g. Benzene, Toluene).





## Closing

- 1 Check that all the sealing surfaces are clean.
- 2 Brush the threads of the bolts clean, using a steel wire brush. Lubricate the threads with a thin layer of grease, e.g. Gleitmo 800 or equivalent.

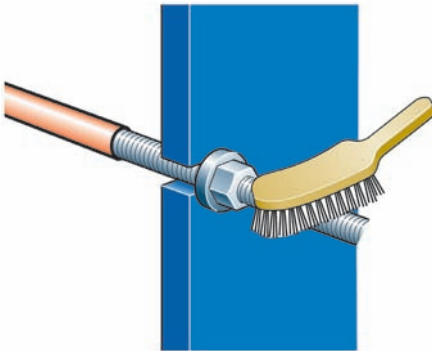

- 3 Attach gaskets to the plates or check that all the gaskets are properly attached.

### Note!

If the gasket is wrongly positioned, it will show by the fact that it rises out of the gasket groove or that it is positioned outside the groove.

- 4 Insert the plates with the herring bone pattern positioned in alternate directions and with the gaskets turned towards the frame plate.

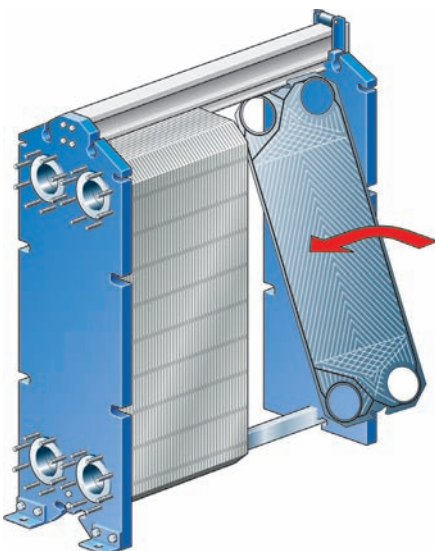

- 5 Press the plate assembly together. Tightening is done in two steps, see figures below. Be careful so that the frame plate and the pressure plate are always in parallel.

Step	Bolt No.	To dimension
1	1-2 or 3-4	1,10A
2	1-2-3-4	A

Step 1: Tighten the two diagonal pairs of bolts alternately until the plate package measures 1,10A.

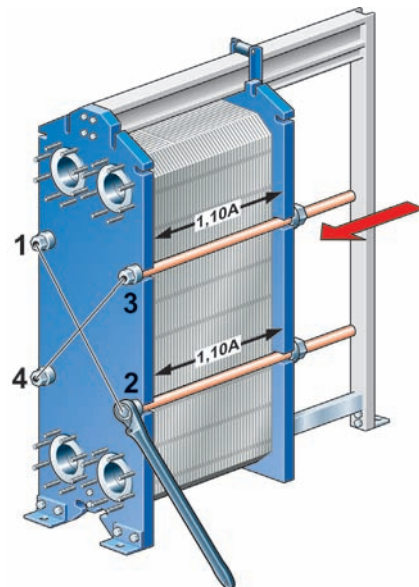

Step 2: After that bolts are tightened alternately and diagonally, as shown in the figure below. Check the dimension A during tightening at the positions of the bolts that are being used.

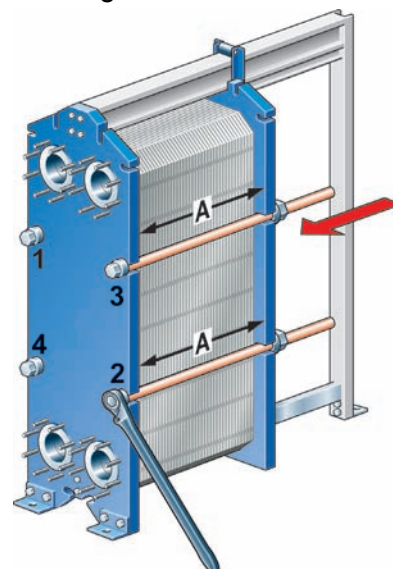

**Max tightening torque**

**Note!**

When a pneumatic tightening device is used, see table below for maximum torque. Measure dimension A during tightening.

Bolt size	Bolt with bearing box		Bolt with washers	
	N·m	kpm	N·m	kpm
M24			450	45
M30			900	90
M39	1300	130	2000	200
M48	2100	210	3300	330

For manual tightening, the tightening torque has to be estimated.

**If dimension A cannot be reached**

- Check the number of plates and the dimension A.
- Check that all the nuts and bearing boxes are running freely. If not, clean and lubricate, or replace.

The dimension A can be exceeded in exceptional cases. The following plate package lengths could then be accepted:

Plate package length/plate	Plate package length (dimension A)
>4 mm	A + 1 %
3–4 mm	A + 1,5 %
<3 mm	A + 2 %

**6**

Place the other bolts in position.

- Inspect the washers.
- When fully tightened, the bolts should all be equally tensioned.
- The difference between the plate package lengths (the dimension A) measured at adjacent bolts should not exceed:
  - 2 mm when A <1000 mm
  - 4 mm when A >1000 mm.

- The plate package length at all bolts must not differ more than 1 %.
- If the unit does not seal fully, it can be tightened to give dimension A – 1 %. The maximum tightening torque must not, however, be exceeded.

eng

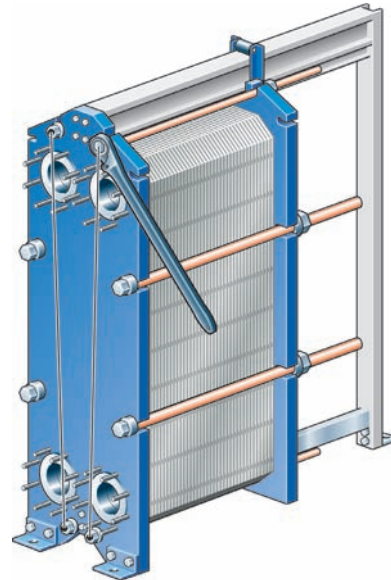

**7**

If the plates are correctly assembled, the edges form a “honeycomb” pattern, see picture below.

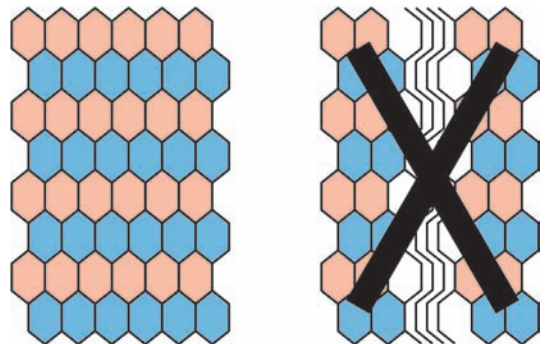



## Pressure test after maintenance

Before start-up of production, whenever plates or gaskets have been removed, inserted or exchanged, it is strongly recommended to perform a pressure test to confirm the internal and external sealing function of the PHE. At this test, one media side at the time must be tested with the other side open to the atmosphere.

The pressure testing shall be performed at a pressure equal to the operating pressure of the actual unit but never above the design pressure as stated on the nameplate.

The recommended test time is 10 minutes.

Please note that PHE units for refrigeration applications and units with media not mixable with water must be dried after hydrostatic pressure testing.

Please consult the local office/representative of the supplier for advice on the pressure testing procedure.

## Regasketing

### Clip-on gaskets

- 1 Open the plate heat exchanger according to page 9, and remove the plate that is to have a new gasket.
- 2 Remove the old gasket.
- 3 Assure that all sealing surfaces are dry, clean and free of foreign matters.
- 4 Attach the clip-on gasket to the plate. Slip the gasket prongs under the edge of the plate.

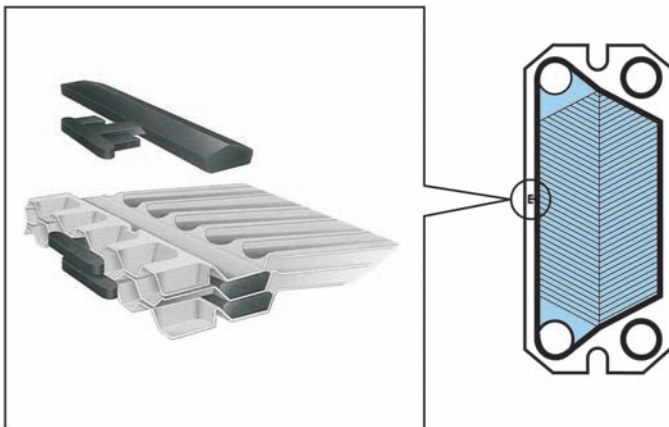

### Note!

Make sure the two gasket prongs are in correct position.

- 5 Proceed with the next plate to be regasketed until all plates in need of regasketing are done with.
- 6 Close the plate heat exchanger according to page 14.

### Clip-AD gaskets (MX25)

The Clip-AD gasket represents a system with the conventional Clip-on fastening around the ports and fastening by means of adhesive tape along the sides of the plates.

The use of the adhesive tape (GC1) is a simple way to obtain secure gasket positioning. It is adhered to the gasket groove by means of a special tape pistol, making it easy to apply the tape exactly where wanted.

- 1 Open the plate heat exchanger according to page 9, and remove the plate that is to have a new gasket.
- 2 Remove the old gasket.
- 3 It is not necessary to remove old tapes as the film is very thin. Make sure, however, that the gasket groove is clean and dry.
- 4 Adhere tape, using the pistol.

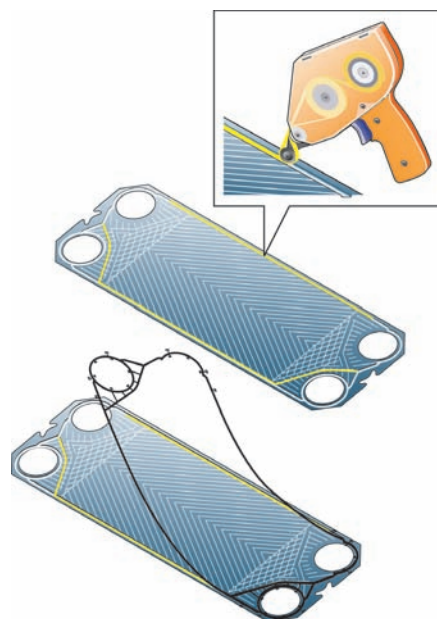





**5** Attach the gasket to the plate. Slip the gasket prongs under the edge of the plate.

**6** Close the plate heat exchanger according to page 14.

### **Glued gaskets**

Separate gluing instructions will be delivered together with the glue.