

SP Series Base Mounted Centrifugal Pumps

2

SP Series Pump with Floating Retainer

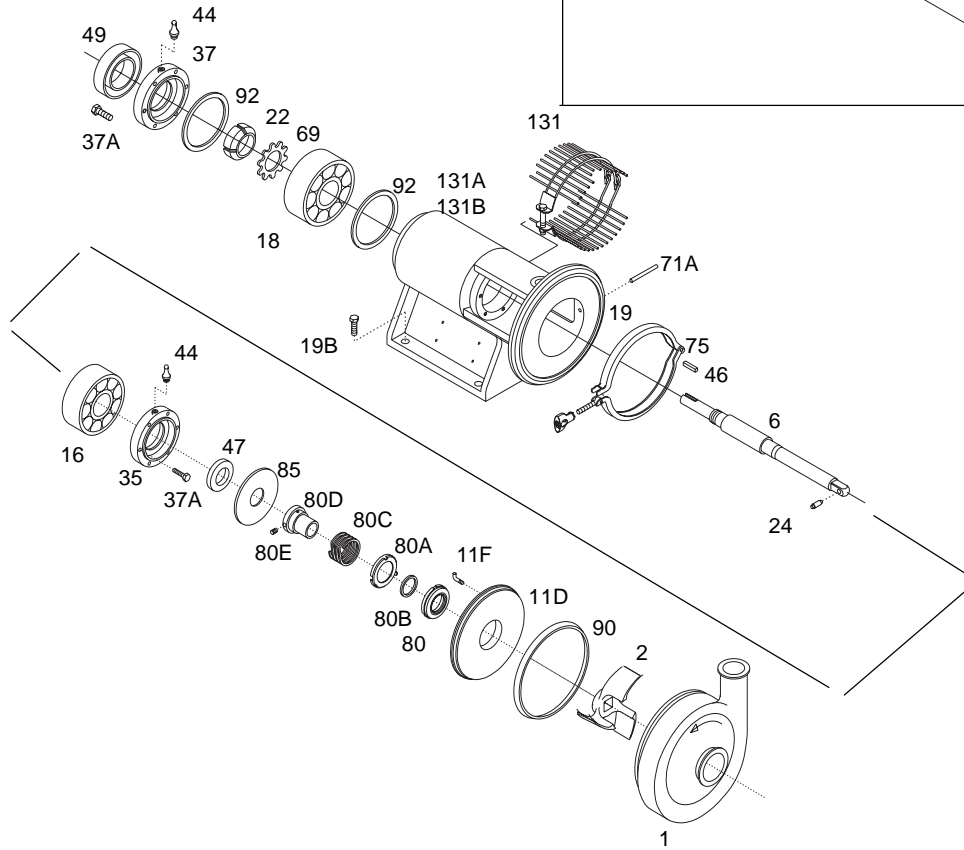

Threaded Shaft and Castellated Nut Retainer System for Use with Type D, F or E Seals

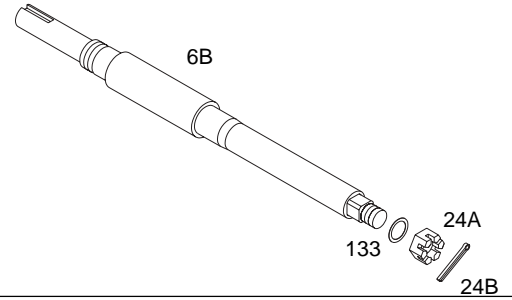

Type E Water Cooled Balanced Double Seal

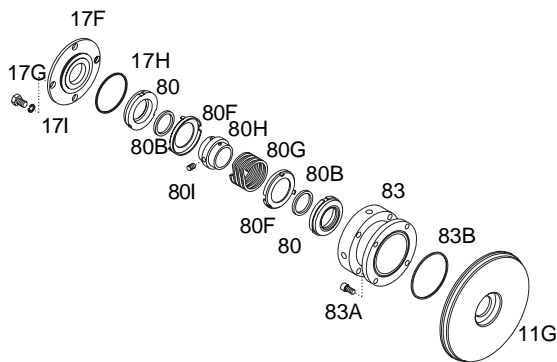

Optional Power Frame Oiler

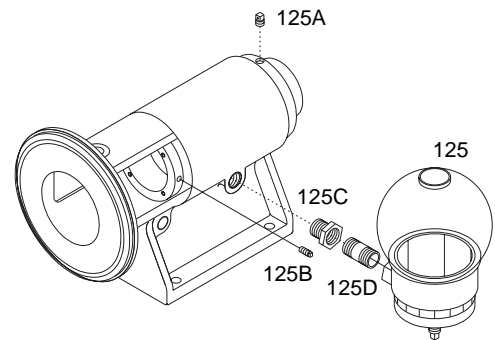

A Packing Gland Seal

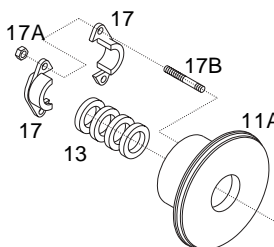

B Packing Gland Seal with Water

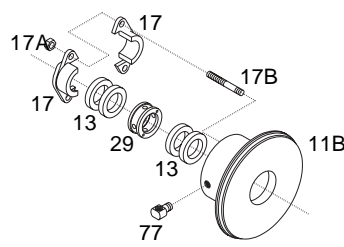

F External Seal with Water Flush

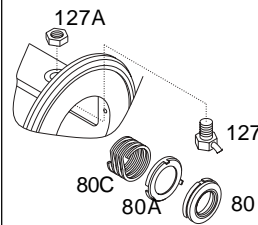

Additional Type DG Clamped-in Seal Seat Components (For use with type D seal)

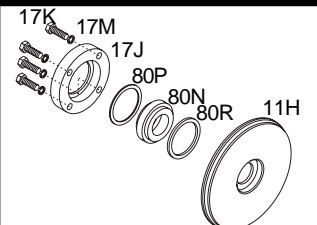

SP Series Base Mounted Centrifugal Pumps

Pos.	Qty.	Description	SP114	SP216	SP218	SP328	SP4410
1	1	Tri-Clamp casing	482815	483122	483755	483841	487978
1	1	Tri-Clamp casing enlarged inlet	483097	483123	483770	484750	488355
1	1	Tri-Clamp circular	480611	480116	480367	480363	*****
1	1	Tri-Clamp unpolished	482823	483627	483724	484742	480359
1	1	Tri-Clamp unpolished enlarged inlet	483172	483160	483775	*****	480585
1	1	bevel seat casing	480980	483642	483761	481779	487986
1	1	NPT casing	481373	483689	483756	485059	487985
1	1	Flanged casing	*****	483607	483715	484110	487983
1	1	Flanged casing enlarged inlet	480388	483114	483769	484746	488354
2	1	Impeller full size	482810	483113	483723	483814	488031
6	1	Shaft pinned style	480539	483701	480544	480544	480546
6B	1	Shaft threaded style	483054	483680	484741	484741	488059
11A	1	Backplate-packing seal	481005	481607	480850	480850	*****
11B	1	Backplate packing water seal	*****	481611	480853	480853	488092
11D	1	Backplate d seal	482891	481620	480866	480866	488103
11F	2	Backplate pin	483263	483263	483263	483263	189972
11G	1	Backplate E seal	482268	482272	482277	482277	482455
11H	◆	Backplate DG seal	480274	480174	480043FH	480043FH	480078
13	1	Packing	180648	180649	180647	180647	180647
16	1	Bearing (inboard)	188157	188256	188326	188326	188326
17	2	Split gland	180740C	180165C	180742C	180742C	180742C
17A	2	Nut (split gland)	189919	189920	189920	189920	189920
17B	2	Stud (split gland)	480099	480806	188593	188593	188593
17F	1	Follower	481811	482275	481211	481211	481211
17G	1	Machine screw	180142	189773	189773	189773	189773
17H	1	O-ring BUNA	755469	751064	751297	751297	751297
17H	1	O-ring EPDM	750134	751538	751634	751634	751634
17H	1	O-ring SFY	751544	751305	751307	751307	751307
17I	◆	4 Lockwasher DG seal	N/A	189962	189962	189962	189962
17J	◆	1 Gland ring DG seal	480275	480176	480050	480050	480050
17K	◆	1 Bolt / screw DG seal	180126	180191	180191	180191	180191
17M	4	Lockwasher	189985	189962	189962	189962	189962
18	1	Bearing (outboard)	188160	188262	188332	188332	188332
19	1	Frame	481019	481605	480862	480862	488142
22	1	Locknut (shaft)	188162	188266	188336	188336	188336
24	■	1 Impeller retainer	482856	483441	484101	484101	480293
24A	1	Catellated nut	481039	480912	480914	480914	480914
24B	1	Cotter pin	480427	480424	755139	755139	755139
29	1	Seal cage	180219	180220	180221	180221	180221
35	1	Bearing cover (inboard)	180797	188301	188341	188341	188341
37	1	Bearing cover (outboard)	180796	188303	188343	188343	188343
37A	8	Bearing cover screw	180336	*****	*****	*****	*****
37A	10	Bearing cover screw	*****	180271	180015	180015	180015
44	2	Grease fitting	188071	180360	180360	180360	180360
46	1	Coupling key	401239	401588	484745	484745	484745
47	1	Bearing (inboard)	188167	188278	188351	188351	188351
49	1	Bearing seal (outboard)	483057	483625	484744	484744	484744

- included in D Balanced Service Kits
- included in E Balanced Service Kits
- included in DG Service Kits

SP Series Base Mounted Centrifugal Pumps

4

SP Series Pump with Floating Retainer

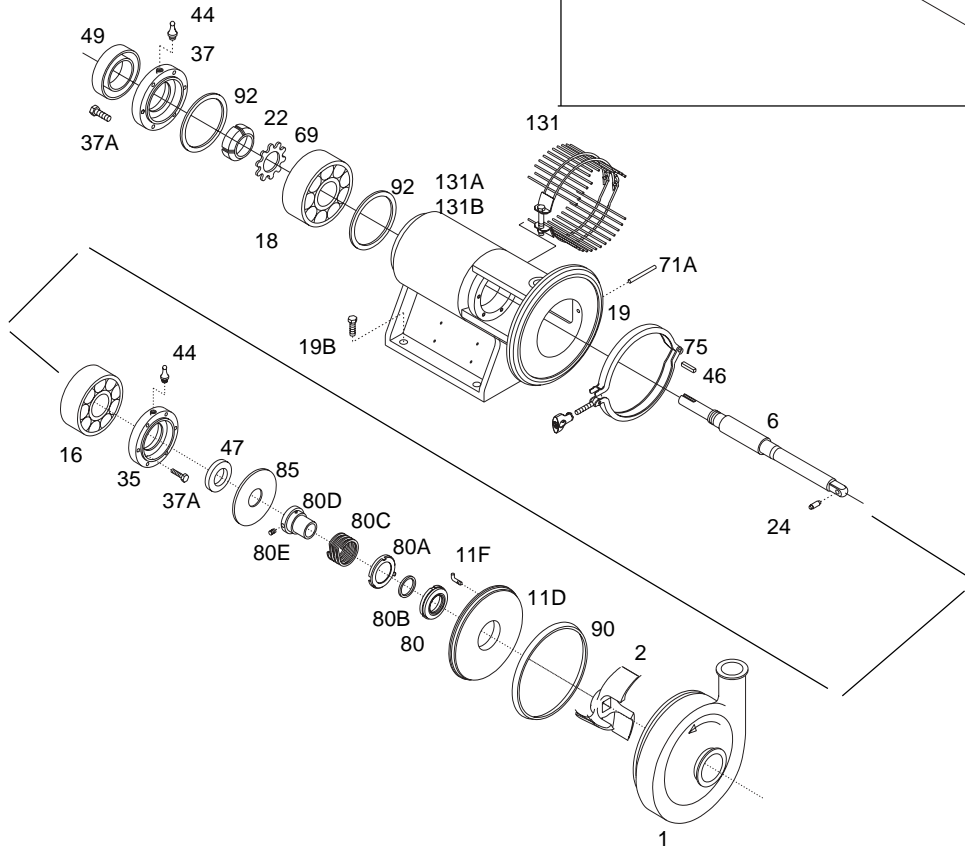

Threaded Shaft and Castellated Nut Retainer System for Use with Type D, F or E Seals

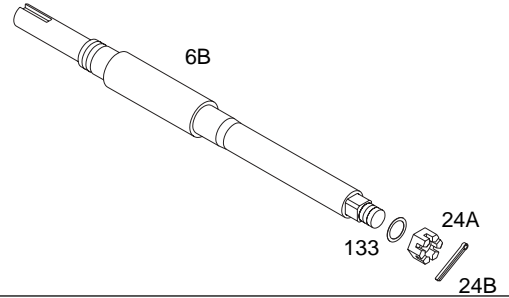

Type E Water Cooled Balanced Double Seal

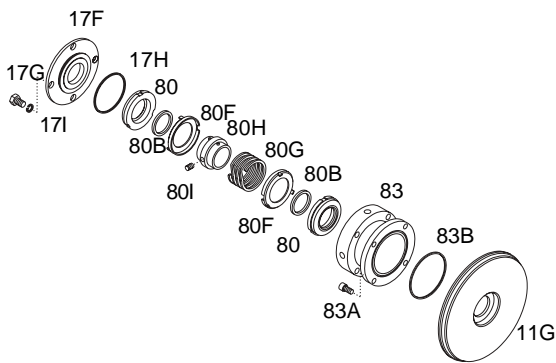

Optional Power Frame Oiler

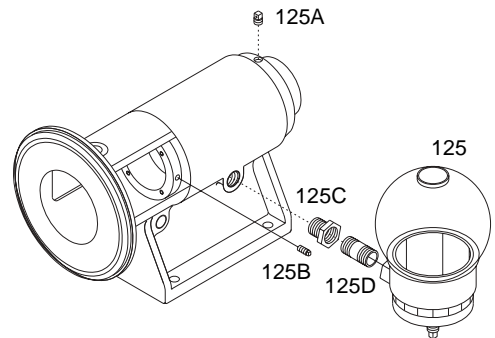

A Packing Gland Seal

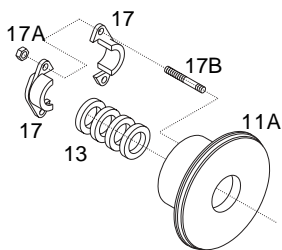

B Packing Gland Seal with Water

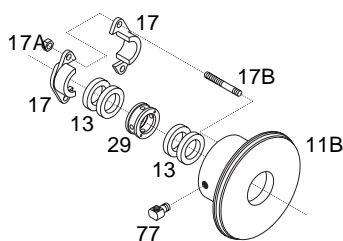

F External Seal with Water Flush

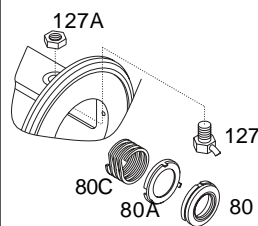

Additional Type DG Clamped-in Seal Seat Components (For use with type D seal)

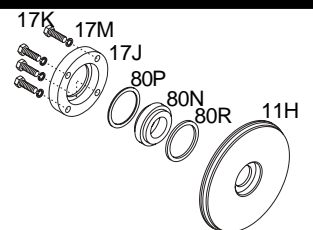

SP Series Base Mounted Centrifugal Pumps

Pos.	Qty.	Description	SP114	SP216	SP218	SP328	SP4410
69	1	Lock washer	188169	188284	188355	188355	188355
71A	1	Adapter pin (external seal)	483396	481621	481621	481621	488079
75	1	Clamp assembly	481488	482258	480285	480285	481624
77	2	Elbow	182150	182150	182150	182150	182150
80	●●○	Carbon seal	480739	480510	480525	480525	480525
80A	■●	Cup	482866	483601	484362	484362	484362
80B	■●○	O-ring BUNA	299060	300552	480479	480479	480479
80B	■●○	O-ring EPDM	290213	300027	480226	480226	480226
80B	■●○	O-ring SFY	290161	300064	480656	480656	480656
80C	■●○	Spring	482867	483602	484363	484363	484363
80D	1	Drive collar	480988	481628	480864	480864	480864
80E	2	Set screw	189815	189840	189840	189840	189840
80F	○	Cup (E balanced)	481327	481333	481209	481209	481209
80G	○	Spring (E balanced)	481324	481334	481210	481210	481210
80H	1	Drive collar (E balanced)	481270	481271	481212	481212	481212
80I	2	Set screw (E balanced)	189838	189819	189819	189819	189819
80N	■	Type DG seal seat (TC)	480470	480477	480466	480466	480466
80N	■◆	Type DG seal seat (SC)	481518	481519	481470	481470	481470
80N	■	Type DG seal seat (CER)	480351	480111	480238	480238	480238
80P	■◆	Gasket outboard (PTFE)	481520	481521	481522	481522	481522
80R	■◆	Gasket inboard (PTFE)	482807	482808	482809	482809	482809
83	1	Stuffing box (E-balanced)	481844	482276	482280	482280	482280
83A	4	Machine screw (E-balanced)	180457	180142	180705	180705	180705
83B	1	O-ring BUNA	751064	755489	755528	755528	755528
83B	1	O-ring EPDM	751538	750081	750575	750575	750575
83B	1	O-ring SFY	751305	750740	751306	751306	751306
85	1	Slinger	300989	300964	300967	300967	300967
90	■●○	Casing gasket BUNA	482737	483195	484083	484083	488389
90	■●○	Casing gasket EPDM	480109	480096	480232	480232	480729
90	■●○	Casing gasket SFY	480633	480201	480575	480575	480861
92	1	Shim-bearing (set)	180384	180383	180382	180382	180382
125	1	Oiler	188046	188046	188046	188046	188046
125A	1	Pressure relief valve	188068	188068	188068	188068	188068
125B	1	Pipe plug	181254	181254	181254	181254	181254
125C	1	Reducer	188063	188063	188063	188063	188063
125D	1	Nipple	188044	188044	188044	188044	188044
127	1	Water inlet assembly	480992	481614	481771	481771	481771
127A	1	Locknut	480990	480990	480990	480990	480990
131	1	Seal guard assembly	481834	481836	481838	481838	481840
133	1	Washer (impeller .005)	481240	481243	481246	481246	481246
133	1	Washer (impeller .010)	481241	481244	481247	481247	481247

- included in D Balanced Service Kits
- included in E Balanced Service Kits
- included in DG Service Kits
- ◆ included in DG conversion Kits (D to DG)

	SP114	SP216	SP218/328	SP4410
● Buna	9613990025	9613990028	9613990031	9613990034
● EPDM	9613990026	9613990029	9613990032	9613990035
● SFY	9613990027	9613990030	9613990033	9613990036
○ Buna	9613990001	9613990004	9613990007	9613990010
○ EPDM	9613990002	9613990005	9613990008	9613990011
○ SFY	9613990003	9613990006	9613990009	9613990012
■ Buna SC Stat.	482207	482208	482211	9613990512
■ EPDM SC Stat.	9613990454	9613990461	9634600055	9613990513
■ SFY SC Stat.	482212	482214	482215	9613990514
■ Buna CER Stat.	9613990455	9613990462	9613990468	9613990515
■ EPDM CER Stat.	9613990456	9613990463	9613990469	9613990516
■ SFY CER Stat.	9613990457	9613990464	9613990470	9613990517
■ Buna TC Stat.	9613990458	9613990465	9613990471	9613990518
■ EPDM TC Stat.	9613990459	9613990466	9613990472	9613990519
■ SFY TC Stat.	9613990460	9613990467	9613990473	9613990520
◆ Conversion kits				
SC Stationary	482122	482123	482124	