



RODEM[®]

PROCESS EQUIPMENT

www.rodem.com 800-543-7312

Instruction Manual

Alfa Laval Toftejorg™ TJ20G

With

- Standard
- Distillery
- Secured
- High temp
- Hastelloy
- 3.1 Inspection Certificate – EN10204
- ATEX Certification in accordance with Directive 94/9/EC

IM-TE91A600-EN8

ESE01794EN

Date of issue: January 20, 2015

First published: June 2000

Original manual

Contents

Toftejorg TJ20G, Product Program	3
Introduction	5
Marking	6
Serial number explanation	6
ATEX Marking	6
Serial number explanation	7
Intended use	8
Patents and trademarks	8
General Description	9
Quality system	9
Functionality	9
Technical Data	11
Dimensions	11
Performance Data	12

Installation

Installation Manual – Contents	13
General Installation Instructions	14
Special Conditions for Safe Use – ATEX	16

Operation

Operational Manual - Contents	19
Operation	20
Cleaning Media	20
Product	20
Pressure	20
Temperature	20
After Use Cleaning	21
Safety Precautions	22

Maintenance

Maintenance Manual – Contents	23
Preventive Maintenance Guidelines	24
Service and Repair of ATEX approved machines	25
Maintenance intervals and Service Kits selection	26
Minor Service Kit for Toftejorg™ TJ20G	27
Major Service Kit for Toftejorg™ TJ20G	28
Available add-on's for Spare parts	29
General recommendations	29
Assembly drawing	30
Reference list of parts	31

Toftejorg™ TJ20G, TE20G000_024 + TE20G050_054 (except TE20G010-TE20G018) .	31
Toftejorg™ TJ20G, TE20G010_014	32
Toftejorg™ TJ20G, TE20G016_018	33
Toftejorg™ TJ20G, TE20G030_044	34
Toftejorg™ TJ20G, TE20HXXX	35
Toolkit and tools for assembly and disassembly	36
Standard Tool Kit for Toftejorg™ TJ20G.....	36
Torque Wrench Tool Kit for Toftejorg™ TJ20G.....	36
Disassembly	37
Assembly	39
Replacement of Ball Races.....	41
Trouble Shooting Guide.....	42
Symptom: Loose Nozzle Hub.....	42
Symptom: Slow rotation or failure of machine to rotate.....	42
Symptom: Slow rotation or failure of machine to rotate (continued).....	43
How to Order Spare Parts	44
How to contact Alfa Laval Tank Equipment.....	44

Miscellaneous

Misc. - Contents.....	45
EU Declaration of Conformity incl. ATEX	46
Declaration of Conformity, EN 10474, sub clause 2.2 Test Report	47
ATEX-Special Conditions for safe use	49
Declaration of Compliance with 10/2011 – Food contact materials	50

Toftejorg TJ20G, Product Program

This manual covers the product program for Toftejorg™ TJ20G tank cleaning machine

Toftejorg™ TJ20G options

Connection	Nozzles (mm)	Standard Article No.	Distillery Article no.	Hastelloy Article no.	Secured Article no.	High temp. Article no.
1" BSP Female	4 x ø3.9	TE20G000-xx	TE20G030-xx	TE20H000(-x0)	TE20G010-xx	TE20G016-x2
	4 x ø4.6	TE20G002-xx	TE20G032-xx	TE20H002(-x0)	TE20G012-xx	TE20G017-x2
	4 x ø5.5	TE20G004-xx	TE20G034-xx	TE20H004(-x0)	TE20G014-xx	TE20G018-x2
1" NPT Female	4 x ø3.9	TE20G020-xx	TE20G040-xx	TE20H020(-x0)		
	4 x ø4.6	TE20G022-xx	TE20G042-xx	TE20H022(-x0)		
	4 x ø5.5	TE20G024-xx	TE20G044-xx	TE20H024(-x0)		
1" BSP Female Sanitary*	4 x ø3.9	TE20G050-xx		TE20H050(-x0)		
	4 x ø4.6	TE20G052-xx		TE20H052(-x0)		
	4 x ø5.5	TE20G054-xx		TE20H054(-x0)		

*see below for choices of sanitary welding connectors

Index no.:

TE20GXXX (no postfix): version w. PVDF impeller

TE20GXXX-X2: version w. PEEK impeller

TE20HXXX (no postfix): Hastelloy version w. PEEK impeller

Available documentation add-on's

TE20XXXX-7X: ATEX

TE20XXXX-8X: 3.1 cert. + ATEX

TE20XXXX-9X: 3.1 cert

Explanation to Add-on's:

3.1 certificate: Declaration of Compliance according to EN 10204 type 3.1 inspection Certificate

ATEX includes:

For TE20X000_054 except TE20G016_018:

ATEX approved machine for use in explosive atmospheres. Category 1 for installation in zone 0/20 in accordance to Directive 94/9/EC. Ex II 1 GD c T140°C.

For TE20G016_018:

ATEX approved machine for use in explosive atmospheres. Category 1 for installation in zone 0/20 in accordance to Directive 94/9/EC. Ex II 1 GD c T250°C Tamb 0°C to +200°C.

Available welding connection

Welding adapter (see right) with sealing assembly between Down pipe, Welding adapter and machine.

Welding connections are ordered separately.

For use with sanitary connection cones use cone with seal (seals are included for machines with sanitary cone).

Pipe Dimension in mm	Connection		
		Thread	Article no.
1" ISO thread pipe:	ø33.7 x 3.25	1" BSP	TE52D030
1" ANSI Sch.40S:	ø33.4 x 3.38	1" NPT	TE52D031
1 ½" ISO Dairy pipe:	ø38 x 1.2	1" BSP	TE52D032

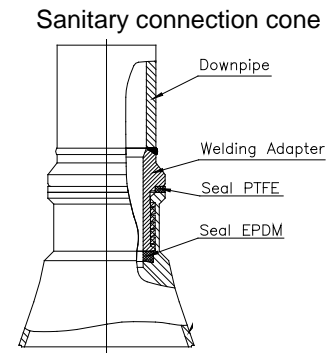
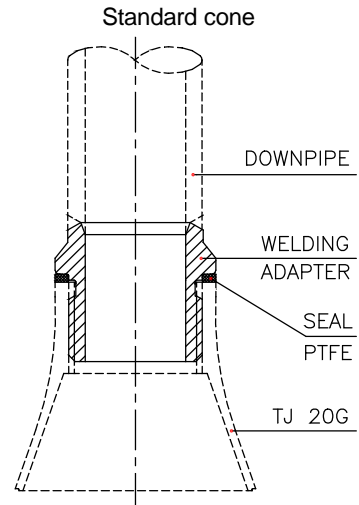

Introduction

With a new revolutionary patented design, the Toftejorg™ TJ20G introduces a new generation of tank cleaning machines.

Based on more than 30 years' experience from practical tank cleaning and production, the Toftejorg™ TJ20G has been developed to meet the highest demands for efficiency, reliability and hygiene within food and beverage, pharmaceutical and biochemical industry.

This manual has been prepared as a guide for the persons who will be operating and maintaining your tank cleaning machine. The key to long life for your tank cleaning machine is always a system of carefully planned maintenance; you will appreciate that a tank cleaning machine that has a rough and dirty job to do, needs more frequent attention than one working in ideal conditions.

Warning:

It is in your own interest to get the best and most economical performance from your tank cleaning machine. Neglect of maintenance means poor performance, unscheduled stoppages, shorter life and expense. Good maintenance means good performance; no unscheduled stoppages and better total economy.

If the TJ20G stops rotating unintentionally within the warranty period, please return the machine to Alfa Laval Kolding A/S. Please do not try to fix any mechanical problems before shipping.

Marking

Alfa Laval tank cleaning machines are all marked to allow recognition of machine type, machine name, Serial number and manufacturing address. The marking are placed on the body of the tank cleaning machine.

Rotary Jet Head
 TJ20G
 s/n.: yyyy-xxxxx
 Alfa Laval, DK-6000 Kolding, Albuen 31
 CE

Serial number explanation

Machines supplied with or without normal documentation:

yyyy-xxxxx: serial number
 yyyy: year
 xxxxx: 5 digit sequential number

Marking area

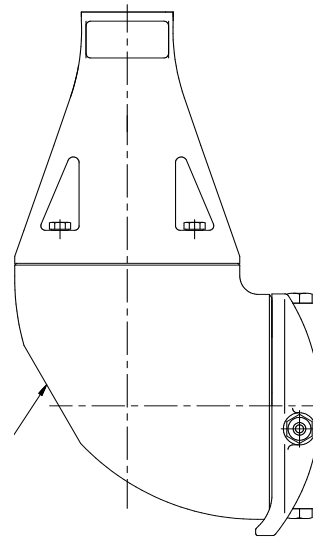

Note: The illustrations and specifications contained in this manual were effective at the date of printing. However, as continuous improvements are part of our policy, we reserve the right to alter or modify any unit specification on any product without prior notice or any obligation.

ATEX Marking

The Toftejorg™ TJ20G is certified as category I component. The certification is carried out by the certified body Baseefa, who has issued the certificate no. 04ATEX0358X. The marking on the ATEX certified Toftejorg™ TJ20G is as follows:

Rotary Jet Head
 TJ20G
 s/n.: yyyy-xxxxx
 Alfa Laval, DK-6000 Kolding, Albuen 31
 Ex II 1GD c T140°C
 CE 1180 Baseefa 04ATEX0358X

Note:

TE20G016-72, TE20G017-72 and TE20G018-72
 TE20G016-82, TE20G017-82 and TE20G018-82.
 These machines has a special ATEX text for the “Ex” line.
 Next to the “Ex” symbol this text shall be present:

II 1 GD c T250°C Tamb 0°C to +200°C

Serial number explanation

Machines supplied with or without normal documentation:

yyyy-xxxxx: serial number

yyyy: year

xxxxx: 5 digit sequential number

Changes to the machine are not allowed without approval by the person responsible for the ATEX certification at Alfa Laval Kolding A/S. If changes are made – or spare parts other than Alfa Laval original spare parts are used - the EC Type Examination certification (the ATEX Directive) is no longer valid.

**Important
ATEX
information:**



Also see page 25 regarding special conditions for repair of ATEX certified machines.

Intended use

It is to be verified by the end-user that

- the TJ20G tank cleaning machine is in conformity with respect to tank -, vessel - or container size in which it intended to be used.
- the construction materials (both metallic and non-metallic) are compatible with product, flushing media, cleaning media, temperatures and pressure under the intended use.

To ensure the self cleanability and drainability the machine must be installed in vertical position

Warning:



Before installation and operation of the tank cleaning machine carefully read the General Installation Instructions (page 14), the special conditions for safe use in accordance with ATEX Certification, Directive 94/9/EC (page 16) and the Safety Precautions (page 22) and take all necessary precautions according to your application and local regulations.

Patents and trademarks

This Instruction Manual is published by Alfa Laval Kolding A/S without any warranty. Improvements and changes to this Instruction Manual may at any time be made by Alfa Laval Kolding A/S without prior notice. Such changes will, however, be incorporated in new editions of this Instruction Manual.

© Alfa Laval Kolding A/S. All rights reserved.

The Alfa Laval logotype is a trademark or a registered trademark of Alfa Laval Corporate AB. "Toftejorg" is a trademark or registered trademark of Alfa Laval Kolding A/S. The Toftejorg™ TJ20G product has patents in the EPO member states (EP 0 560 778), in the US (5333630) and in other countries and has a new patent pending (PCT/DK/2007/000062). Other products or company names mentioned herein may be the trademarks of their respective owners. Any rights not expressly granted herein are reserved

© Alfa Laval Corporate AB

This document and its contents is owned by Alfa Laval Corporate AB and protected by laws governing intellectual property and thereto related rights. It is the responsibility of the user of this document to comply with all applicable intellectual property laws. Without limiting any rights related to this document, no part of this document may be copied, reproduced or transmitted in any form or by any means (electronic, mechanical, photocopying, recording, or otherwise), or for any purpose, without the expressed permission of Alfa Laval Corporate AB. Alfa Laval Corporate AB will enforce its rights related to this document to the fullest extent of the law, including the seeking of criminal prosecution.

General Description

The Toftejorg™ TJ20G is a media driven and media lubricated tank cleaning machine. No lubricating substances such as oil, grease etc. are used. All materials are selected for contact with food, and the machine is self-cleaning i.e. all internal and external surfaces can be cleaned.

For use in explosive hazard zones the media version can be used, provided it is installed according to safety instructions in local regulations.

Quality system

The TJ20G is designed in accordance with the EHEDG design guidelines for sanitary design of processing equipment. It is produced according to Alfa Laval Kolding A/S' ISO 9001 International Standard certified quality system. All parts are made from certified material and all non-metal parts are made from FDA and EU compliant materials.

Functionality

The flow of cleaning fluid into the machine passes through a turbine, which accordingly is set into rotation. Through a gear set and a driver tube, the turbine rotation is transmitted to the Cleaner Head.

The combined motion of the machine Body and the Nozzles ensure a fully indexed tank cleaning coverage. After $5\frac{5}{8}$ revolutions of the Hub cover with Nozzles ($5\frac{3}{8}$ revolutions of the machine Body), one coarse cleaning pattern is laid out on the tank surface and the first cycle has been made. During the following cycles, this pattern is repeated 7 times, each of which is displaced, and the pattern gradually becomes more dense. Finally, after 8 cycles - a total of 45 revolutions of the Hub Cover with Nozzles (43 revolutions of the machine Body), a complete cleaning pattern has been laid out, and the first pattern is repeated.

This is illustrated below for a spherical tank with the machine placed in the centre:

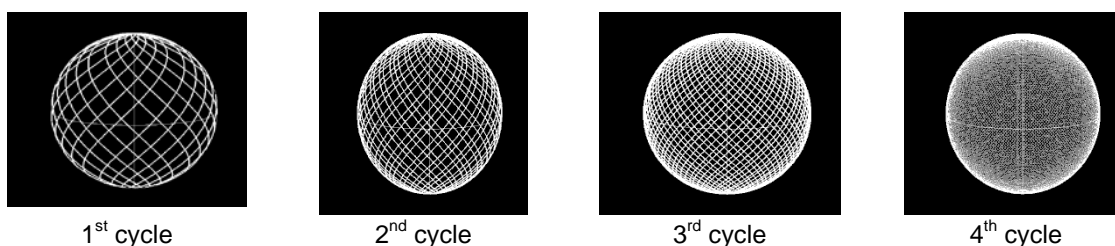

The number of cycles needed to perform a proper cleaning depends on type of soilage, distance, cleaning procedure, cleaning temperature and cleaning agent.

For substances that are easily mobilised, i.e. are easy to remove, one cycle could be sufficient while in cases of heavier soiling (high viscous, sticky substances, etc.) a more dense pattern/more cycles are needed.

The rotation speed of the turbine depends on the flow rate through the machine. The higher the flow rate, the higher the speed of rotation. In order to control the RPM of the machine for a wide range of flow rates, the machine has different turbines according to the Nozzle size.

Apart from the main flow flushing the gear and the Hub, and thereafter forming the jets through the Nozzles, fluid is flushed through all internal areas, through Bevel gear, Ball bearings and gaps between moving parts and finally also used for cleaning of the outside surfaces of the machine. The areas behind the Screws on the Cone are cleaned through small spray holes behind the Screws. To ensure self-draining a hole is located at the bottom of the Body. This self-draining is only ensured, if the machine is installed in upright position.

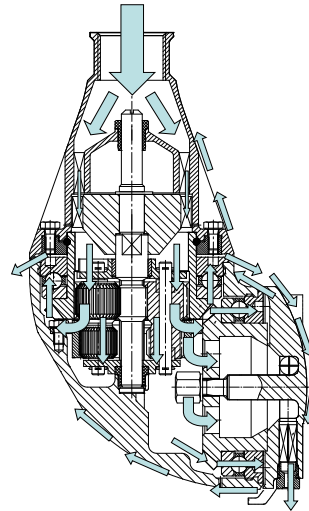

For Sanitary connection version:

The threaded connection between downpipe and machine is not a product contact surface as it is enclosed using two seals and the welding adaptor.

For all versions:

For devices with tapered thread connections to the down pipe, it is recommended that you secure the connection in a manner appropriate for the application. Subject to the intended use environment and any in house user requirements or policies, an adhesive such as Loctite No. 243 or equivalent could be used. Other methods could be acceptable and subject to customer preference.

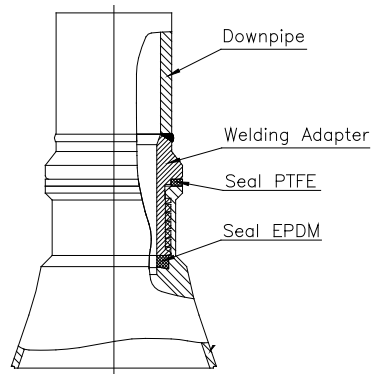

Technical Data

Weight of machine	: 5.1 kgs (11.2 lb)
Working pressure	: 3-8 bar (40-115 psi)
Recommended inlet pressure	: 5-7 bar (70-100 psi)
Working temperature max.	: 95°C (200°F)
Ambient temperature	: 0 - 140°C (95°C/200°F - 140°C/284°F when not operated)
No-EPDM machines	: 0 - 200°C (95°C/200°F - 200°C/392°F when not operated)
TE20G016-72/TE20G016-82	
TE20G017-72/TE20G017-82	
TE20G018-72/TE20G018-82	
Materials	: Stainless Steel AISI 316L, SAF 2205, PFA, PEEK, PVDF, A4/EPDM
Materials - Hastelloy	: Hastelloy C22, Hastelloy C276, PEEK, Viton, PFA

Dimensions

All dimensions are given in mm

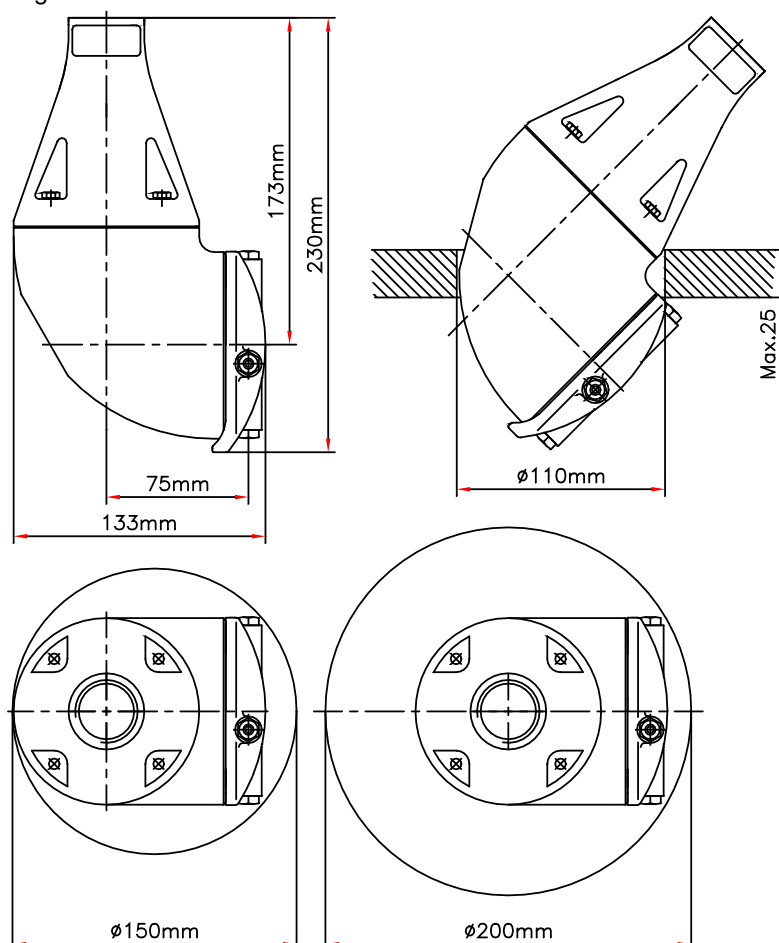

Minimum required passage:

$\phi 110\text{ mm}$ (4.33 inch) at flange thickness of maximum 25 mm (0.98 inch)

Otherwise $\phi 150\text{ mm}$ (5.90 inch)

Performance Data

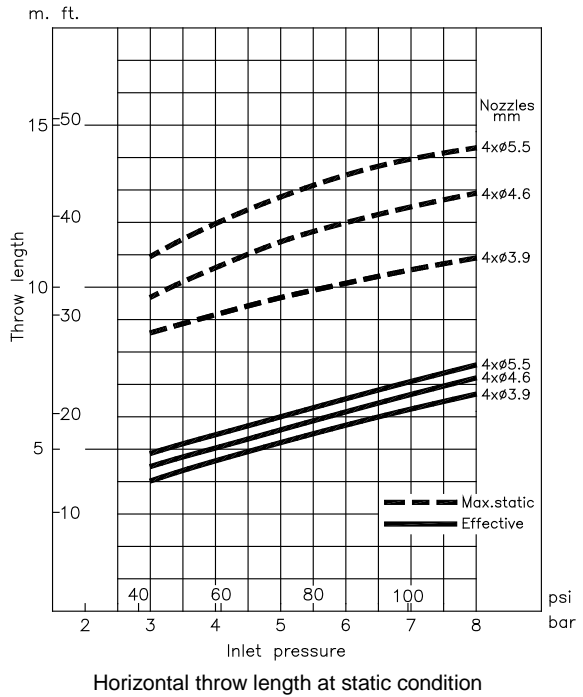
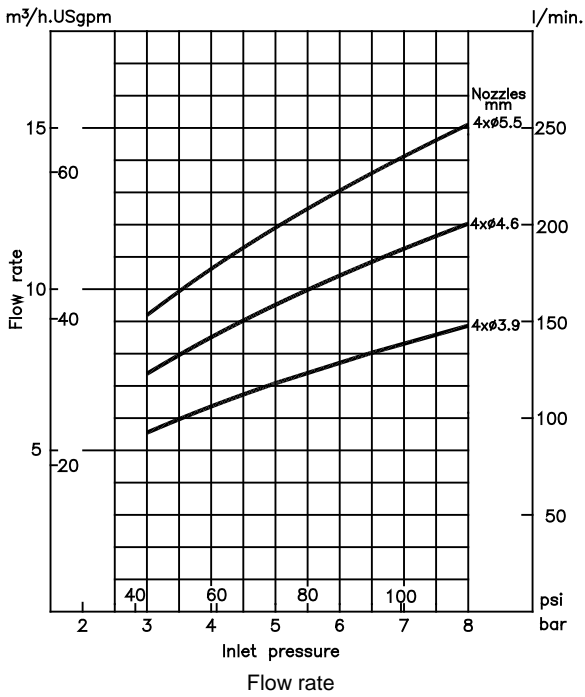

Distillery version (20G030_044) – flow at 5 bar:

- 4 x Ø3.9 = 10 m³/h
- 4 x Ø4.6 = 12.4 m³/h
- 4 x Ø5.5 = 13.9 m³/h

Min. RPM of machine body

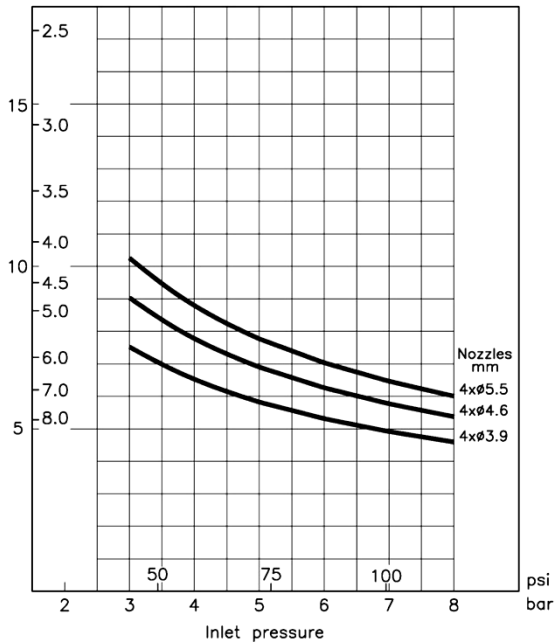

Cleaning time, complete pattern

Effective throw length is defined as 250 mm water column (50 lbs/sq.ft.) impact force in centre of jet. However, effective throw length varies depending on jet transverse speed over surface, substance to be removed, cleaning procedure and agent.

Note: Throw lengths are measured as horizontal throw length at static condition.

Vertical throw lengths upwards are approx. 1/3 less.

The inlet pressure has been measured immediately at the machine inlet. In order to achieve the performance indicated in the curves, pressure drop in the supply lines between pump and machine must be taken into consideration.

Installation

Installation Manual – Contents

General Installation Instructions	14
Special Conditions for Safe Use – ATEX	16

General Installation Instructions

The tank cleaning machine should be installed in vertical position (upright or upside down). It is recommended to install a filter in the supply line in order to avoid large particles, scale etc. to clog inside the machine. It is essential to avoid fine solid particles (e.g. fine sand) in cleaning fluid as they will increase wear considerably.

In general a filter with 3 mm holes is recommended in the supply line. In case of fine solid particles below 500 µm in the cleaning fluid, choose filter size accordingly.

In order to separate the CIP system from the process it is recommended to install a shutoff valve close to the machine inlet. This will also prevent back-flow of liquid from the tank through the machine in case the cleaner head is submerged and there is an over-pressure inside the tank. The installation and operation shall be made in such a way that the gravity draining of the machine is ensured.

It is recommended that the fluid valve fitted is of a type that prevents hydraulic shocks, which may cause severe damage to the TJ20G and/or the entire installation. Ideally, a frequency controlled pump with a ramp function for start-up is used for supplying the cleaning liquid.

Before connecting the machine to the system, all supply lines and valves should be flushed in order to remove foreign particles.

The machine should be screwed tightly onto its supporting supply line using a 36 mm flat jawed spanner (tool No. TE81B040) on the flats machined on the inlet Cone.

During handling and installation handle the machine with care in order not to damage the surface finishes of the machine.

The TJ20G machine has been tested at the factory before shipping. You can check that the machine is in operating condition by blowing compressed air into the inlet, while holding the machine by the cone and verify that the rest of the machine rotates evenly. If resistance is recognised, the machine should be disassembled in order to localise the cause or returned to the nearest Alfa Laval Service Centre).

Upon arrival check that the machine is in operating condition by inserting a flathead Screwdriver in top of Turbine shaft and easily turn Turbine shaft anti-clockwise. If any resistance is recognised, the machine should be disassembled in order to localise the cause.

For devices with tapered thread connections to the down pipe, it is recommended that you secure the connection in a manner appropriate for the application. Subject to the intended use environment and any in-house user requirements or policies, an adhesive such as Loctite No. 243 or equivalent could be used. Other methods could be acceptable and subject to customer preference.

Note: Do not try to turn the Nozzle head by hand, since this may damage the Gear. The Nozzle head can be turned by blowing compressed air through the inlet connection.

Note: The machine shall be installed in accordance with national regulations for safety and other relevant regulations and standards. In EU-countries the complete system must fulfil the EU-Machinery Directive and depending of application, the EU-Pressure Equipment Directive, the EU-ATEX Directive and other relevant Directives and shall be CE-marked before it is set into operation.

Warning: Precautions shall be made to prevent starting of the cleaning operation, while personnel are inside the tank or otherwise can be hit by jets from the nozzles.



ATEX
Warning: If the machine is used in potential explosive atmospheres, tapes or joint sealing compounds which are electrical insulators must not be used on threads or joints, unless an electrical connection is otherwise established to ensure that the machine is effectively grounded. In addition, connecting pipe work must be electrically conductive and grounded to the tank structure. The resistance between the nozzles and the tank structure should not exceed 20,000 Ohm. This is essential to avoid the build-up of static electricity on the machine. For further information see DS/CLC/TR 50404:2003 Safety of Machinery, guidance and recommendations for the avoidance of hazards due to static electricity.



Special Conditions for Safe Use – ATEX

In accordance with the ATEX Certification, Directive 94/9/EC the following special conditions shall be obeyed.

ATEX Warning: The unit may be operated, in a hazardous area, only when filled with the process fluid.



ATEX Warning:



For standard machines:

Working temperature max:

The maximum permitted process fluid temperature and ambient temperature when the machine is operating is 95°C.

Ambient temperature:

When the machine is **not** operating, the maximum permitted ambient temperature is 140°C.

For high-temperature machines:

TE20G016-72 and TE20G016-82

TE20G017-72 and TE20G017-82

TE20G018-72 and TE20G018-82

Working temperature max:

The maximum permitted process fluid temperature and ambient temperature when the machine is operating is 95°C.

Ambient temperature:

When the machine is **not** operating, the maximum permitted ambient temperature is 200°C.

ATEX Warning: The maximum permitted process fluid pressure is 8 bar.



Continues on next page.

**ATEX
Warning:**



The unit must not be operated in a vessel having an enclosed volume of greater than 100m³.

Tanks larger than 100 m³:

To use Tank Cleaning Machines in tanks larger than 100m³ is possible under certain conditions.

It is necessary to know the current factors such as tank size, cleaning solvent and product.

Additives can be used in the cleaning solvent, or, for example, the tank can be filled with nitrogen. The basic rules are described in the guide "CLC / TR 50404:2003".

Following a guidance document such as "CLC / TR 50404:2003" to establish safe use of machinery and process is the users own responsibility and is not covered by the ATEX certification for this product.

In addition to the above mentioned precautions relating to the ATEX guidelines Directive 94/9/EC of March 23 1994, the general safety precautions, page 22, must be observed.

Intentionally left blank

Operation

Operational Manual - Contents

Operation	20
Cleaning Media	20
Product	20
Pressure	20
Temperature	20
After Use Cleaning.....	21
Safety Precautions.....	22

Operation

Cleaning Media

Use only media/chemicals compatible with stainless steel AISI 316L, SAF 2205, PVDF or PEEK, PFA HP and EPDM. For more aggressive chemicals consider using the Hastelloy version. Normal detergents, moderate solutions of acids and alkalis will be acceptable. Aggressive chemicals, excessive concentrations of chemicals at elevated temperatures, as well as certain hypochlorite's should be avoided. If you are in doubt, contact your local Alfa Laval sales office.

Note: PEEK is not resistant to concentrated sulphuric acid

Product

In cases where the machine is submerged in, or in other ways exposed to, product the compatibility between stainless steel AISI 316L, SAF 2205, PVDF or PEEK, PFA and EPDM and the product must be considered carefully. For more aggressive products consider using the Hastelloy version.

Note: EPDM swells significantly exposed to fatty materials

Pressure

Avoid hydraulic shocks. Increase pressure gradually. Do not exceed 8 bar inlet pressure. Recommended inlet pressure: 5-7 bar. High pressure (leading to high flow rates) increases consumption of wear parts. High pressure also reduce the cleaning effect.

**ATEX
Warning:**



Steam cleaning pressure:

If steam cleaning is done through the machine, the steam pressure must not cause the machine to rotate.

**ATEX
Warning:**



Draining:

If the machine is drained using compressed air, then the compressed air pressure must not cause the machine to rotate.

Temperature

Standard versions:

The maximum recommended process fluid temperature is 95°C. The recommended ambient temperature range is 0°C to 140°C.

No-EPDM versions:

The maximum recommended process fluid temperature is 95°C. The recommended ambient temperature range is 0°C to 200°C.

In accordance with the ATEX specifications regarding special conditions for safe use, see page 16.

ATEX Warning: 	<u>Atmosphere/surface temperature:</u> In potentially explosive atmospheres, the temperature must not exceed the maximum surface temperature according to the temperature class for the combustible gas or liquid.
---	---

ATEX Warning: 	<u>Steam cleaning:</u> Tanks with capacities greater than 100 m ³ that could contain a flammable atmosphere should not be steam cleaned, as steam issuing from a nozzle could contain charged droplets. Tanks smaller than this may be steam cleaned providing that: the steam nozzles and other metal parts of the system are reliably earthed and grounded to the tank structure.
---	--

After Use Cleaning

After use flush the machine with fresh water. Cleaning media should never be allowed to dry or settle in the system due to possible "salting out" or "scaling" of the cleaning media. If cleaning media contains volatile chloride solvents, it is recommended not to flush with water after use, as this might create hydrochloric acid.

Safety Precautions

The machine is intended for use inside a tank only. As peak velocity of main jets reaches 40 m/s, TJ20G must not be operated in open air or when tank is open.

Warning: Hot chemicals and steam under pressure may be used for cleaning and sterilising. Protect against scalding and burning. Never tamper with or try to open clamps or other connections while system is in operation. Make sure that system is de-pressurised and drained before disassembly.



The cleaning jets impinging the tank surface are a source of noise. Depending on pressure and distance to the tank walls, noise level may reach up to 85 dB.

ATEX In case potentially explosive liquids are used, precautions should be taken against incidental creation of an explosive mixture with oxygen in the tank atmosphere.

Warning:



Warning: Tanks may contain poisonous/hazardous products or products which represent an environmental or safety risk. Never open tank and dismantle the machine without checking previous tank contents and necessary precautions.



Maintenance

Maintenance Manual – Contents

Preventive Maintenance Guidelines	24
Service and Repair of ATEX approved machines	25
Maintenance intervals and Service Kits selection	26
Minor Service Kit for Toftejorg™ TJ20G	27
Major Service Kit for Toftejorg™ TJ20G	28
Available add-on's for Spare parts.....	29
General recommendations.....	29
Assembly drawing	30
Reference list of parts.....	31
Toftejorg™ TJ20G, TE20G000_024 + TE20G050_054 (except TE20G010-TE20G018) .	31
Toftejorg™ TJ20G, TE20G010_014	32
Toftejorg™ TJ20G, TE20G016_018	33
Toftejorg™ TJ20G, TE20G030_044	34
Toftejorg™ TJ20G, TE20HXXX	35
Toolkit and tools for assembly and disassembly	36
Standard Tool Kit for Toftejorg™ TJ20G.....	36
Torque Wrench Tool Kit for Toftejorg™ TJ20G.....	36
Disassembly	37
Assembly	39
Replacement of Ball Races.....	41
Trouble Shooting Guide.....	42
Symptom: Loose Nozzle Hub.....	42
Symptom: Slow rotation or failure of machine to rotate.....	42
Symptom: Slow rotation or failure of machine to rotate (continued).....	43
How to Order Spare Parts	44
How to contact Alfa Laval Tank Equipment.....	44

Preventive Maintenance Guidelines

Following the Alfa Laval Tank Equipment Preventive Maintenance Guidelines and using the Alfa Laval Service Kits ensures the availability of your equipment at all times and enables you to plan your operating budget and your downtime. The risk of unscheduled breakdowns due to component failure is virtually eliminated and in the long term your operating costs are reduced.

Alfa Laval Tank Cleaning Equipment Service Kits contain all you need. They comprise genuine Alfa Laval spare parts, manufactured to the original specifications.

The following recommended preventive maintenance program is based on tank cleaning machines working in average conditions. However, a tank cleaning machine, exposed to heavy soiling and recirculation CIP liquid containing abrasives and/or particulates, needs more frequent attention than one exposed to light/no soiling and recirculation with ordinary CIP liquid. Alfa Laval Kolding A/S recommends you to adjust the maintenance program to suit the cleaning task in hand. Contact your local Alfa Laval sales office for discussion.

Note: Handle the TJ20G with care. Take proper action to protect surfaces from being damaged.

Always use only proper tools and the TJ20G standard tool kit. Never use force, hammer or pry components together or apart. Always perform all assembly/disassembly steps in the order described in this manual.

Clean all surfaces prior to assembling. Especially take care of the mating surfaces. Work in a clear well-lighted work area.

According to "Regulation (EC) No 1935/2004 - Article 17" effective from 27th of October 2006, producers of food shall ensure traceability of the materials and articles intended to come into contact with foodstuffs. It is recommended that a traceability system is setup for replacement of wear parts and spare parts. This makes it possible to identify into which machine a given wear part or spare part has been inserted.

Service and Repair of ATEX approved machines

In order to ensure compliance with the ATEX regulations for service and repair in accordance with EN 60079-19, all service and repair of ATEX approved machines should be performed by Alfa Laval Kolding A/S, Ishoej, Denmark, or Alfa Laval service centre approved by Alfa Laval Kolding A/S.

Warning: ATEX requirements regarding repair of ATEX approved machines according to EN 60079-19.



A tag with the following labelling information must be attached to the machine:

- Repair symbol 
- Alfa Laval logo and address
- Repair number
- Date of repair
- Machine serial number

The tag must be laminated and attached to the machine using a cable tie.

If a customer wishes to carry out service or repair himself, it is the responsibility of the repair shop to ensure that the ATEX requirements are met in any way possible. After performing service or repair, the repair shop thus carries the full responsibility for the ATEX approval of the machine.

Maintenance intervals and Service Kits selection

It is recommended that the wear parts are checked every 500 working hours for machine working under normal conditions. There is a Minor and a Major service kit* for the TJ20G (see the following pages).

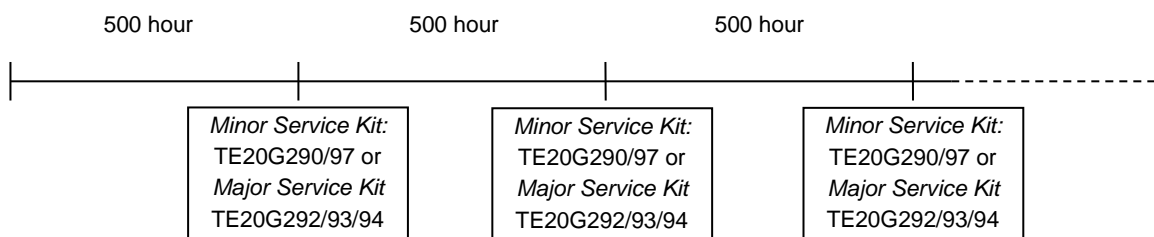

*For the Hastelloy machines (TE20HXXX) a special major service kit is used (see the following pages).

Every 500 working hours

1. Disassemble machine as described on the following pages.
2. Clean material build-up and deposits from internal parts with Scotch-brite, S-Ultra-fine, eventually chemical media and fine abrasive cloth.
3. Check Slide bearing (Pos. 14, page 30) for wear. If end face of Slide bearing is worn more than 1 mm into Slide bearing, it should be replaced.
4. Check bearing for Turbine shaft top (Pos. 24, page 30) in Cone and Body. If holes are worn oval to a max. diameter of more than 10.4 mm, Bearings should be replaced. Thickness of collar is to be min. 3.5 mm for Bearing in Body. If the Bearings are loose in a horizontal direction, the bearings should be replaced.
5. Check Carrier bearing (Pos. 15.3, page 30). If worn oval to a max. diameter of more than 15.8 mm, it should be replaced.

Note: Timely replacement of Slide bearings and bearings for Turbine shaft will prevent costly damage to the gearbox.

6. Check Planet wheels (Pos. 15.4 and 15.5, page 30) while still mounted in planet gear carrier (Pos. 15.6, page 30). They must rotate easily on Shafts. If restriction or much clearance on Shafts is felt, Planet wheels should be dismantled for inspection of bearing bushes and Shafts for Planet wheel (Pos. 15.2, page 30). Max diameter of holes: 6.2 mm.

Check tooth wear.

If replacement is necessary, Planet wheels must be replaced as a pair.

7. Check unrestricted rotation of Ball bearings. Inspect for build-up of foreign material on Stem nut (Pos. 9, page 30) and Hub nut (Pos. 18, page 35), in Ball retainers (Pos. 10, page 35) and Ball races.
8. Inspect the nozzle vanes for foreign objects (e.g. product pulp, threads, etc.) and if necessary clean with care – damaging nozzles (or fouled nozzles) will decrease the throw length of the machine. Clean using compressed air or tweezers.

9. Replace washer (pos. 22, page 30).
10. Assemble machines as described in the following pages.
11. Check that the machine is in operating condition by inserting flathead Screwdriver in top of Turbine shaft, and easily turn Turbine shaft anti-clockwise. If any resistance is recognised, the machine should be disassembled in order to localise the cause.
12. If Ball races (Pos. 16.2 and 17.2) on Stem and Hub as well as Stem/Hub nut w. Ball race (Pos. 9 and 18) and Washer (Pos. 22) are heavily worn, they should be replaced. Also the Ball retainer w. balls (Pos. 10, see page 41) should be replaced if heavily worn.

Apart from the parts specifically mentioned above, all the remaining wear parts should regularly be inspected for wear. Wear parts are specified in the Reference List of Parts, page 31.

Minor Service Kit for Toftejorg™ TJ20G

For all machines with serial number under 0604 xxxx please contact your local Alfa Laval office for correct service kit.

Article no.: TE20G290 - All models except TE20G016_018 (see below).

Pos. no.	Part No.	Description	No.
3	TE20G640	Bearing for Turbine shaft	1 piece
14	TE20G641	Slide bearing	1 piece
15.3	TE20G642	Bearing for Planet Gear carr.	1 piece
15.4	TE20G643	Planet wheel I	1 piece
15.5	TE20G644	Planet wheel II	1 piece
22	TE20G584*	Washer	1 piece
24	TE20G548	Bearing for Turbine shaft top	1 piece

*For Hastelloy machines (20HXXX) the washer (Pos. 24) in the minor service kit is not used.

Article no.: TE20G291 - TE20G016_018 (No-EPDM version)

Pos. no.	Part No.	Description	No.
3	TE20G640	Bearing for Turbine shaft	1 piece
14	TE20G641	Slide bearing	1 piece
15.3	TE20G642	Bearing for Planet Gear carr.	1 piece
15.4	TE20G643	Planet wheel I	1 piece
15.5	TE20G644	Planet wheel II	1 piece
22	TE51B021	Washer	1 piece
24	TE20G548	Bearing for Turbine shaft top	1 piece

Major Service Kit for Toftejorg™ TJ20G

Article no.: TE20G292 – All models except TE20G016_018 & TE20G030_044 (see below).

Pos. no.	Part No.	Description	No.
3	TE20G640	Bearing for Turbine shaft	1 piece
9	TE20G571	Stem nut with ball race	1 piece
10	TE20G318	Ball retainer w. balls	2 pieces
14	TE20G641	Slide bearing	1 piece
15.1	TE51C102	Cotter pin	2 pieces
15.3	TE20G642	Bearing for Planet Gear carr.	1 piece
15.4	TE20G643	Planet wheel I	1 piece
15.5	TE20G644	Planet wheel II	1 piece
17.2	TE20G574	Ball race	2 pieces
18	TE20G573	Hub nut with ball race	1 piece
22	TE20G584	Washer	1 piece
24	TE20G548	Bearing for Turbine shaft top	1 piece

Article no.: TE20G293 – TE20G016_018 (No-EPDM version)

Pos. no.	Part No.	Description	No.
3	TE20G640	Bearing for Turbine shaft	1 piece
9	TE20G571	Stem nut with ball race	1 piece
10	TE20G318	Ball retainer w. balls	2 pieces
14	TE20G641	Slide bearing	1 piece
15.1	TE51C102	Cotter pin	2 pieces
15.3	TE20G642	Bearing for Planet Gear carr.	1 piece
15.4	TE20G643	Planet wheel I	1 piece
15.5	TE20G644	Planet wheel II	1 piece
17.2	TE20G574	Ball race	2 pieces
18	TE20G573	Hub nut with ball race	1 piece
22	TE51B021	Washer	1 piece
24	TE20G548	Bearing for Turbine shaft top	1 piece

Article no.: TE20G294 – TE20G030_044 (Distillery version)

Pos. no.	Part No.	Description	No.
3	TE20G640	Bearing for Turbine shaft	1 piece
9	TE20G636	Stem nut with ball race	1 piece
10	TE20G318	Ball retainer w. balls	2 pieces
14	TE20G641	Slide bearing	1 piece
15.1	TE51C102	Cotter pin	2 pieces
15.3	TE20G642	Bearing for Planet Gear carr.	1 piece
15.4	TE20G643	Planet wheel I	1 piece
15.5	TE20G643	Planet wheel II	1 piece
17.2	TE20G574	Ball race	2 pieces
18	TE20G633	Hub nut with ball race	1 piece
22	TE20G584	Washer	1 piece
24	TE20G548	Bearing for Turbine shaft top	1 piece

Article no.: TE20H292 – TE20HXXX version.

Pos. no.	Part No.	Description	No.
3	TE20G640	Bearing for Turbine shaft	1 piece
9	TE20H571	Stem nut with ball race	1 piece
10	TE20H318	Ball retainer w. balls	2 pieces
14	TE20G641	Slide bearing	1 piece
15.1	TE20H542	Cotter pin	2 pieces
15.3	TE20G642	Bearing for Planet Gear carr.	1 piece
15.4	TE20G643	Planet wheel I	1 piece
15.5	TE20G644	Planet wheel II	1 piece
17.2	TE20H574	Ball race	2 pieces
18	TE20H573	Hub nut with ball race	1 piece
24	TE20G548	Bearing for Turbine shaft top	1 piece

Available add-on's for Spare parts

Item no.	Description
TE20XXXX-8X TE20XXXX-9X	<ul style="list-style-type: none"> • Declaration of Compliance: <ul style="list-style-type: none"> - EN 10204 type 3.1 inspection Certificate - FDA Declaration of Compliance

General recommendations

- Always read the instruction and maintenance manuals carefully before undertaking the service.
- Always replace all parts included in the Service Kit.
- Prior to assembly/disassembly clean all tools and fixtures to ensure that scratches and marks and trace of soil/corrosion from tools are avoided.
- Do not scratch or damage the surfaces of the machine.
 - Always place components on soft material

Check surfaces for product residues and clean all parts before assembly. Assembly of the machine is described on the following pages.

Assembly drawing

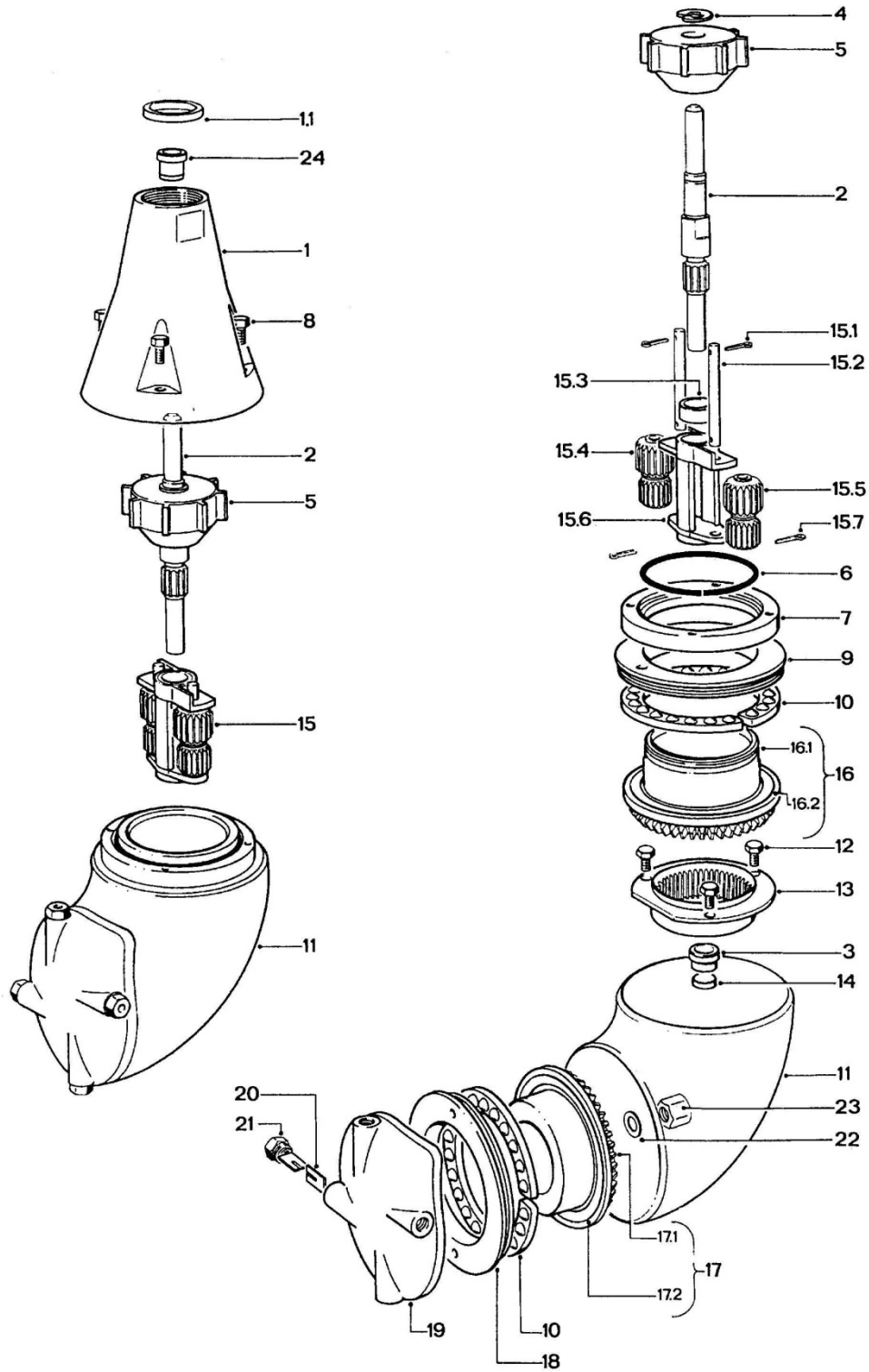

Reference list of parts

Toftejorg™ TJ20G, TE20G000_024 + TE20G050_054 (except TE20G010-TE20G018)

Pos.	Ref. No.	No/Unit	Description	Materials	Remarks
1	<input type="checkbox"/> TE20G508	1	Cone 1" BSP	Stainless steel	Spare part
	<input type="checkbox"/> TE20G517	1	Cone 1" NPT	Stainless steel	Spare part
	<input type="checkbox"/> TE20G518	1	Cone 1" BSP f. sanitary conn.	Stainless steel	Spare part
1.1	<input type="checkbox"/> TE51T212	1	Gasket (only f. TE20G518)	Elastomer	Spare part
2	TE20G550	1	Turbine shaft	Stainless steel	Spare part
3	TE20G640	1	Bearing for Turbine shaft	Polymer	Wear part
4	TE51C201	1	Circlip	Stainless steel	Spare part
5	<input type="checkbox"/> TE20G553	1	Impeller (ø3.5/3.9 mm nozzle)	Polymer (PVDF)	Spare part
	<input type="checkbox"/> TE20G554	1	Impeller (ø4.5/4.6 mm nozzle)	Polymer (PVDF)	Spare part
	<input type="checkbox"/> TE20G555	1	Impeller (ø5,5 mm nozzle)	Polymer (PVDF)	Spare part
	<input type="checkbox"/> TE20G595	1	Impeller (ø3.5/3.9 mm nozzle)	Polymer (PEEK)	Spare part
	<input type="checkbox"/> TE20G596	1	Impeller (ø4.5/4.6 mm nozzle)	Polymer (PEEK)	Spare part
	<input type="checkbox"/> TE20G597	1	Impeller (ø5.5 mm nozzle)	Polymer (PEEK)	Spare part
6	TE20G565	1	Retainer spring	Stainless steel	Spare part
7	TE20G563	1	Retaining ring	Stainless steel	Spare part
8	TE51A172	4	Screw	Stainless steel	Spare part
9	TE20G571	1	Stem nut with ball race	Stainless steel	Wear part
10	TE20G318	2	Ball retainer with balls	Polymer/Stainless steel	Wear part
11	TE20G512	1	Body	Stainless steel	Spare part
12	TE51A170	3	Screw	Stainless steel	Spare part
13	TE20G525	1	Internal gear	Stainless steel	Spare part
14	TE20G641	1	Slide bearing	Polymer	Wear part
15	TE20G340	1	Carrier assembly	Assembly	Spare part
15.1	TE51C102	(2)	Cotter pin	Stainless steel	Spare part
15.2	TE20G541	(2)	Shaft for Planet wheel	Stainless steel	Spare part
15.3	TE20G642	(1)	Bearing for planet gear carrier	Polymer	Wear part
15.4	TE20G643	(1)	Planet wheel I	Polymer	Wear part
15.5	TE20G644	(1)	Planet wheel II	Polymer	Wear part
15.6	TE20G530	(1)	Planet gear carrier	Stainless steel	Spare part
15.7	TE51C102	(2)	Cotter pin (= pos. 15.1)	Stainless steel	Spare part
16	TE20G319	1	Stem complete	Assembly	Spare part
16.1	TE20G624	(1)	Stem	Stainless steel	Spare part
16.2	TE20G574	(1)	Ball race	Stainless steel	Wear part
17	TE20G320	1	Hub complete	Assembly	Spare part
17.1	TE20G625	(1)	Hub	Stainless steel	Spare part
17.2	TE20G574	(1)	Ball race (= pos. 16.2)	Stainless steel	Wear part
18	TE20G573	1	Hub nut with ball race	Stainless steel	Wear part
19	TE20G620	1	Hub cover	Stainless steel	Spare part
20	TE20G594	8	Nozzle vane	Stainless steel	Spare part
21	<input type="checkbox"/> TE20G608	4	Nozzle ø3,9 mm	Stainless steel	Spare part
	<input type="checkbox"/> TE20G609	4	Nozzle ø4,6 mm	Stainless steel	Spare part
	<input type="checkbox"/> TE20G605	4	Nozzle ø5,5 mm	Stainless steel	Spare part
22	TE20G584	1	Washer	Stainless steel	Wear part
23	TE51A521	1	Cap nut	Stainless steel	Spare part
24	TE20G548	1	Bearing for turbine shaft top	Polymer	Wear part

Configuration as delivered marked

Toftejorg™ TJ20G, TE20G010_014

Pos.	Ref. No.	No/Unit	Description	Materials	Remarks
1	<input type="checkbox"/> TE20G503	1	Cone 1" BSP hole f. split	Stainless steel	Spare part
2	TE20G550	1	Turbine shaft	Stainless steel	Spare part
3	TE20G640	1	Bearing for Turbine shaft	Polymer	Wear part
4	TE51C201	1	Circlip	Stainless steel	Spare part
5	<input type="checkbox"/> TE20G553	1	Impeller (ø3.5/3.9 mm nozzle)	Polymer (PVDF)	Spare part
	<input type="checkbox"/> TE20G554	1	Impeller (ø4.5/4.6 mm nozzle)	Polymer (PVDF)	Spare part
	<input type="checkbox"/> TE20G555	1	Impeller (ø5,5 mm nozzle)	Polymer (PVDF)	Spare part
	<input type="checkbox"/> TE20G595	1	Impeller (ø3.5/3.9 mm nozzle)	Polymer (PEEK)	Spare part
	<input type="checkbox"/> TE20G596	1	Impeller (ø4.5/4.6 mm nozzle)	Polymer (PEEK)	Spare part
	<input type="checkbox"/> TE20G597	1	Impeller (ø5.5 mm nozzle)	Polymer (PEEK)	Spare part
6	TE20G565	1	Retainer spring	Stainless steel	Spare part
7	TE20G563	1	Retaining ring	Stainless steel	Spare part
8	TE51A172	4	Screw	Stainless steel	Spare part
9	TE20G571	1	Stem nut with ball race	Stainless steel	Wear part
10	TE20G318	2	Ball retainer with balls	Polymer/Stainless steel	Wear part
11	TE20G512	1	Body	Stainless steel	Spare part
12	TE51A170	3	Screw	Stainless steel	Spare part
13	TE20G525	1	Internal gear	Stainless steel	Spare part
14	TE20G641	1	Slide bearing	Polymer	Wear part
15	TE20G340	1	Carrier assembly	Assembly	Spare part
15.1	TE51C102	(2)	Cotter pin	Stainless steel	Spare part
15.2	TE20G541	(2)	Shaft for Planet wheel	Stainless steel	Spare part
15.3	TE20G642	(1)	Bearing for planet gear carrier	Polymer	Wear part
15.4	TE20G643	(1)	Planet wheel I	Polymer	Wear part
15.5	TE20G643	(1)	Planet wheel II	Polymer	Wear part
15.6	TE20G530	(1)	Planet gear carrier	Stainless steel	Spare part
15.7	TE51C102	(2)	Cotter pin (= pos. 15.1)	Stainless steel	Spare part
16	TE20G319	1	Stem complete	Assembly	Spare part
16.1	TE20G624	(1)	Stem	Stainless steel	Spare part
16.2	TE20G574	(1)	Ball race	Stainless steel	Wear part
17	TE20G320	1	Hub complete	Assembly	Spare part
17.1	TE20G625	(1)	Hub	Stainless steel	Spare part
17.2	TE20G574	(1)	Ball race (= pos. 16.2)	Stainless steel	Wear part
18	TE20G573	1	Hub nut with ball race	Stainless steel	Wear part
19	TE20G630	1	Hub cover incl. mod cap nut	Stainless steel	Spare part
20	TE20G594	8	Nozzle vane	Stainless steel	Spare part
21	<input type="checkbox"/> TE20G608	4	Nozzle ø3,9 mm	Stainless steel	Spare part
	<input type="checkbox"/> TE20G609	4	Nozzle ø4,6 mm	Stainless steel	Spare part
	<input type="checkbox"/> TE20G605	4	Nozzle ø5,5 mm	Stainless steel	Spare part
22	TE20G584	1	Washer	Stainless steel	Wear part
24	TE20G548	1	Bearing for turbine shaft top	Polymer	Wear part
26	TE51C105	1	Cotter pin	Stainless steel	Spare part
27	TE11B536	1	Lock pin	Stainless steel	Spare part
28	TE52D549	1	Spring pin	Stainless steel	Spare part

Configuration as delivered marked

Toftejorg™ TJ20G, TE20G016_018

Pos.		Ref. No.	No/Unit	Description	Materials	Remarks
1	<input type="checkbox"/>	TE20G508	1	Cone 1" BSP	Stainless steel	Spare part
2		TE20G550	1	Turbine shaft	Stainless steel	Spare part
3		TE20G640	1	Bearing for Turbine shaft	Polymer	Wear part
4		TE51C201	1	Circlip	Stainless steel	Spare part
5	<input type="checkbox"/>	TE20G553	1	Impeller (ø3.5/3.9 mm nozzle)	Polymer (PVDF)	Spare part
	<input type="checkbox"/>	TE20G554	1	Impeller (ø4.5/4.6 mm nozzle)	Polymer (PVDF)	Spare part
	<input type="checkbox"/>	TE20G555	1	Impeller (ø5,5 mm nozzle)	Polymer (PVDF)	Spare part
	<input type="checkbox"/>	TE20G595	1	Impeller (ø3.5/3.9 mm nozzle)	Polymer (PEEK)	Spare part
	<input type="checkbox"/>	TE20G596	1	Impeller (ø4.5/4.6 mm nozzle)	Polymer (PEEK)	Spare part
	<input type="checkbox"/>	TE20G597	1	Impeller (ø5.5 mm nozzle)	Polymer (PEEK)	Spare part
6		TE20G565	1	Retainer spring	Stainless steel	Spare part
7		TE20G563	1	Retaining ring	Stainless steel	Spare part
8		TE51A172	4	Screw	Stainless steel	Spare part
9		TE20G571	1	Stem nut with ball race	Stainless steel	Wear part
10		TE20G318	2	Ball retainer with balls	Polymer/Stainless steel	Wear part
11		TE20G512	1	Body	Stainless steel	Spare part
12		TE51A170	3	Screw	Stainless steel	Spare part
13		TE20G525	1	Internal gear	Stainless steel	Spare part
14		TE20G641	1	Slide bearing	Polymer	Wear part
15		TE20G340	1	Carrier assembly	Assembly	Spare part
15.1		TE51C102	(2)	Cotter pin	Stainless steel	Spare part
15.2		TE20G541	(2)	Shaft for Planet wheel	Stainless steel	Spare part
15.3		TE20G642	(1)	Bearing for planet gear carrier	Polymer	Wear part
15.4		TE20G643	(1)	Planet wheel I	Polymer	Wear part
15.5		TE20G644	(1)	Planet wheel II	Polymer	Wear part
15.6		TE20G530	(1)	Planet gear carrier	Stainless steel	Spare part
15.7		TE51C102	(2)	Cotter pin (= pos. 15.1)	Stainless steel	Spare part
16		TE20G319	1	Stem complete	Assembly	Spare part
16.1		TE20G624	(1)	Stem	Stainless steel	Spare part
16.2		TE20G574	(1)	Ball race	Stainless steel	Wear part
17		TE20G320	1	Hub complete	Assembly	Spare part
17.1		TE20G625	(1)	Hub	Stainless steel	Spare part
17.2		TE20G574	(1)	Ball race (= pos. 16.2)	Stainless steel	Wear part
18		TE20G573	1	Hub nut with ball race	Stainless steel	Wear part
19		TE20G620	1	Hub cover	Stainless steel	Spare part
20		TE20G594	8	Nozzle vane	Stainless steel	Spare part
21	<input type="checkbox"/>	TE20G608	4	Nozzle ø3,9 mm	Stainless steel	Spare part
	<input type="checkbox"/>	TE20G609	4	Nozzle ø4,6 mm	Stainless steel	Spare part
	<input type="checkbox"/>	TE20G605	4	Nozzle ø5,5 mm	Stainless steel	Spare part
22		TE51B021	1	Washer w/o EPDM	Stainless steel	Wear part
23		TE51A521	1	Cap nut	Stainless steel	Spare part
24		TE20G548	1	Bearing for turbine shaft top	Polymer	Wear part

Configuration as delivered marked

Toftejorg™ TJ20G, TE20G030_044

Pos.		Ref. No.	No/Unit	Description	Materials	Remarks
1	<input type="checkbox"/>	TE20G508	1	Cone 1" BSP	Stainless steel	Spare part
	<input type="checkbox"/>	TE20G517	1	Cone 1" NPT	Stainless steel	Spare part
2		TE20G550	1	Turbine shaft	Stainless steel	Spare part
3		TE20G640	1	Bearing for Turbine shaft	Polymer	Wear part
4		TE51C201	1	Circlip	Stainless steel	Spare part
5	<input type="checkbox"/>	TE20G553	1	Impeller (ø3.5/3.9 mm nozzle)	Polymer (PVDF)	Spare part
	<input type="checkbox"/>	TE20G554	1	Impeller (ø4.5/4.6 mm nozzle)	Polymer (PVDF)	Spare part
	<input type="checkbox"/>	TE20G555	1	Impeller (ø5,5 mm nozzle)	Polymer (PVDF)	Spare part
	<input type="checkbox"/>	TE20G595	1	Impeller (ø3.5/3.9 mm nozzle)	Polymer (PEEK)	Spare part
	<input type="checkbox"/>	TE20G596	1	Impeller (ø4.5/4.6 mm nozzle)	Polymer (PEEK)	Spare part
	<input type="checkbox"/>	TE20G597	1	Impeller (ø5.5 mm nozzle)	Polymer (PEEK)	Spare part
6		TE20G565	1	Retainer spring	Stainless steel	Spare part
7		TE20G563	1	Retaining ring	Stainless steel	Spare part
8		TE51A172	4	Screw	Stainless steel	Spare part
9		TE20G636	1	Stem nut with ball race	Stainless steel	Wear part
10		TE20G318	2	Ball retainer with balls	Polymer/Stainless steel	Wear part
11		TE20G512	1	Body	Stainless steel	Spare part
12		TE51A170	3	Screw	Stainless steel	Spare part
13		TE20G525	1	Internal gear	Stainless steel	Spare part
14		TE20G641	1	Slide bearing	Polymer	Wear part
15		TE20G340	1	Carrier assembly	Assembly	Spare part
15.1		TE51C102	(2)	Cotter pin	Stainless steel	Spare part
15.2		TE20G541	(2)	Shaft for Planet wheel	Stainless steel	Spare part
15.3		TE20G642	(1)	Bearing for planet gear carrier	Polymer	Wear part
15.4		TE20G643	(1)	Planet wheel I	Polymer	Wear part
15.5		TE20G644	(1)	Planet wheel II	Polymer	Wear part
15.6		TE20G530	(1)	Planet gear carrier	Stainless steel	Spare part
15.7		TE51C102	(2)	Cotter pin (= pos. 15.1)	Stainless steel	Spare part
16		TE20G334	1	Stem complete	Assembly	Spare part
16.1		TE20G634	(1)	Stem	Stainless steel	Spare part
16.2		TE20G574	(1)	Ball race	Stainless steel	Wear part
17		TE20G335	1	Hub complete	Assembly	Spare part
17.1		TE20G635	(1)	Hub	Stainless steel	Spare part
17.2		TE20G574	(1)	Ball race (= pos. 16.2)	Stainless steel	Wear part
18		TE20G633	1	Hub nut with ball race	Stainless steel	Wear part
19		TE20G620	1	Hub cover	Stainless steel	Spare part
20		TE20G594	8	Nozzle vane	Stainless steel	Spare part
21	<input type="checkbox"/>	TE20G608	4	Nozzle ø3,9 mm	Stainless steel	Spare part
	<input type="checkbox"/>	TE20G609	4	Nozzle ø4,6 mm	Stainless steel	Spare part
	<input type="checkbox"/>	TE20G605	4	Nozzle ø5,5 mm	Stainless steel	Spare part
22		TE51B021	1	Washer w/o EPDM	Stainless steel	Wear part
23		TE51A521	1	Cap nut	Stainless steel	Spare part
24		TE20G548	1	Bearing for turbine shaft top	Polymer	Wear part

Configuration as delivered marked

Toftejorg™ TJ20G, TE20HXXXConfiguration as delivered marked

Pos.	Ref. No.	No/Unit	Description	Materials	Remarks
1	<input type="checkbox"/> TE20H508	1	Cone 1" BSP	Hastelloy C22	Spare part
	<input type="checkbox"/> TE20H517	1	Cone 1" NPT	Hastelloy C22	Spare part
	<input type="checkbox"/> TE20H518	1	Cone 1" BSP f. sanitary conn.	Hastelloy C22	Spare part
1.1	<input type="checkbox"/> TE51T220	1	Gasket (only f. TE20G518)	Elastomer	Spare part
2	TE20H550	1	Turbine shaft	Hastelloy C22	Spare part
3	TE20G640	1	Bearing for Turbine shaft	Polymer	Wear part
4	TE20H592	1	Circlip	Hastelloy C22	Spare part
5	<input type="checkbox"/> TE20G595	1	Impeller (ø3.9 mm nozzle)	Polymer (PEEK)	Spare part
	<input type="checkbox"/> TE20G596	1	Impeller (ø4.6 mm nozzle)	Polymer (PEEK)	Spare part
	<input type="checkbox"/> TE20G597	1	Impeller (ø5.5 mm nozzle)	Polymer (PEEK)	Spare part
6	TE20H565	1	Retainer spring	Hastelloy C22	Spare part
7	TE20H563	1	Retaining ring	Hastelloy C22	Spare part
8	TE20H591	4	Screw	Hastelloy C22	Spare part
9	TE20H571	1	Stem nut with ball race	Hastelloy C22	Wear part
10	TE20H318	2	Ball retainer with balls	Polymer/Hastelloy C276	Wear part
11	TE20H512	1	Body	Hastelloy C22	Spare part
12	TE20H590	3	Screw	Hastelloy C22	Spare part
13	TE20H525	1	Internal gear	Hastelloy C22	Spare part
14	TE20G641	1	Slide bearing	Polymer	Wear part
15	TE20H340	1	Carrier assembly	Assembly	Spare part
15.1	TE20H542	(2)	Cotter pin	Hastelloy C22	Spare part
15.2	TE20H541	(2)	Shaft for Planet wheel	Hastelloy C22	Spare part
15.3	TE20G642	(1)	Bearing for planet gear carrier	Polymer	Wear part
15.4	TE20G643	(1)	Planet wheel I	Polymer	Wear part
15.5	TE20G644	(1)	Planet wheel II	Polymer	Wear part
15.6	TE20H530	(1)	Planet gear carrier	Hastelloy C22	Spare part
15.7	TE20H542	(2)	Cotter pin (= pos. 15.1)	Hastelloy C22	Spare part
16	TE20H319	1	Stem complete	Assembly	Spare part
16.1	TE20H624	(1)	Stem	Hastelloy C22	Spare part
16.2	TE20H574	(1)	Ball race	Hastelloy C22	Wear part
17	TE20H320	1	Hub complete	Assembly	Spare part
17.1	TE20H625	(1)	Hub	Hastelloy C22	Spare part
17.2	TE20H574	(1)	Ball race (= pos. 16.2)	Hastelloy C22	Wear part
18	TE20H573	1	Hub nut with ball race	Hastelloy C22	Wear part
19	TE20H620	1	Hub cover	Hastelloy C22	Spare part
20	TE20H594	8	Nozzle vane	Hastelloy C22	Spare part
21	<input type="checkbox"/> TE20H608	4	Nozzle ø3,9 mm	Hastelloy C22	Spare part
	<input type="checkbox"/> TE20H609	4	Nozzle ø4,6 mm	Hastelloy C22	Spare part
	<input type="checkbox"/> TE20H605	4	Nozzle ø5,5 mm	Hastelloy C22	Spare part
22	TE20G548	1	Bearing for turbine shaft top	Hastelloy C22	Wear part
23	TE20H585	1	Cap nut	Hastelloy C22	Spare part
24	TE20H586	1	O-ring	Elastomer	Spare part
25	TE20H587	1	Washer for Cap nut, TJ20G	Hastelloy C22	Spare part

Configuration as delivered marked

Toolkit and tools for assembly and disassembly

Besides the standard toolkit for the TJ20G shown below and the Torque Wrench toolkit (see below) additional tools are needed:

- Flathead screwdriver (size 5/32'')
- Slip joint pliers
- Rubber hammer
- Drift punch (size \varnothing 5 mm)
- Bench vice (large enough to secure the body of the TJ20G)
- 11 mm open ended spanner
- Support ring (only for changing Ball races) - e.g. a piece of pipe with an inner diameter of \varnothing 84

Standard Tool Kit for Toftejorg™ TJ20G

Article no. TE81B085

Tool No.	Description
TE369	Caliper
TE462A	Socket wrench w. pin
TE81B040	Spanner for Toftejorg™ TJ20G (flat jawed)
TE81B041	Spanner (13 mm)

Torque Wrench Tool Kit for Toftejorg™ TJ20G

Article no. TE81B087

Tool No.	Description
TE81B088	Torque wrench with interchangeable ratchet head
TE81B089	Ring insert tool for torque wrench

Disassembly

- D1.1 Remove the 4 Screws (Pos. 8) using a socket wrench (tool No. TE462A).
- D1.2 Lift off Cone (Pos. 1).
- D1.3 Withdraw Turbine shaft (Pos. 2) with Impeller. If necessary, turn Turbine shaft left and right.
- D1.4 Remove Circlip (Pos. 4) using a flathead Screwdriver and pull off Impeller (Pos. 5).
- D1.5 Withdraw Carrier assembly (Pos. 15) while turning/rocking carrier left and right.
- D1.6 Remove Cotter pins (Pos. 15.7) using a slip joint plier, pull out Shafts (Pos. 15.2) and remove Planet wheels (Pos. 15.4 and 15.5). If necessary, push out Carrier bearing (Pos. 15.3)
- D1.7 If necessary, push out Bearing for Turbine shaft top (Pos. 24) from Cone (Pos.1) using tool no. TE462A.

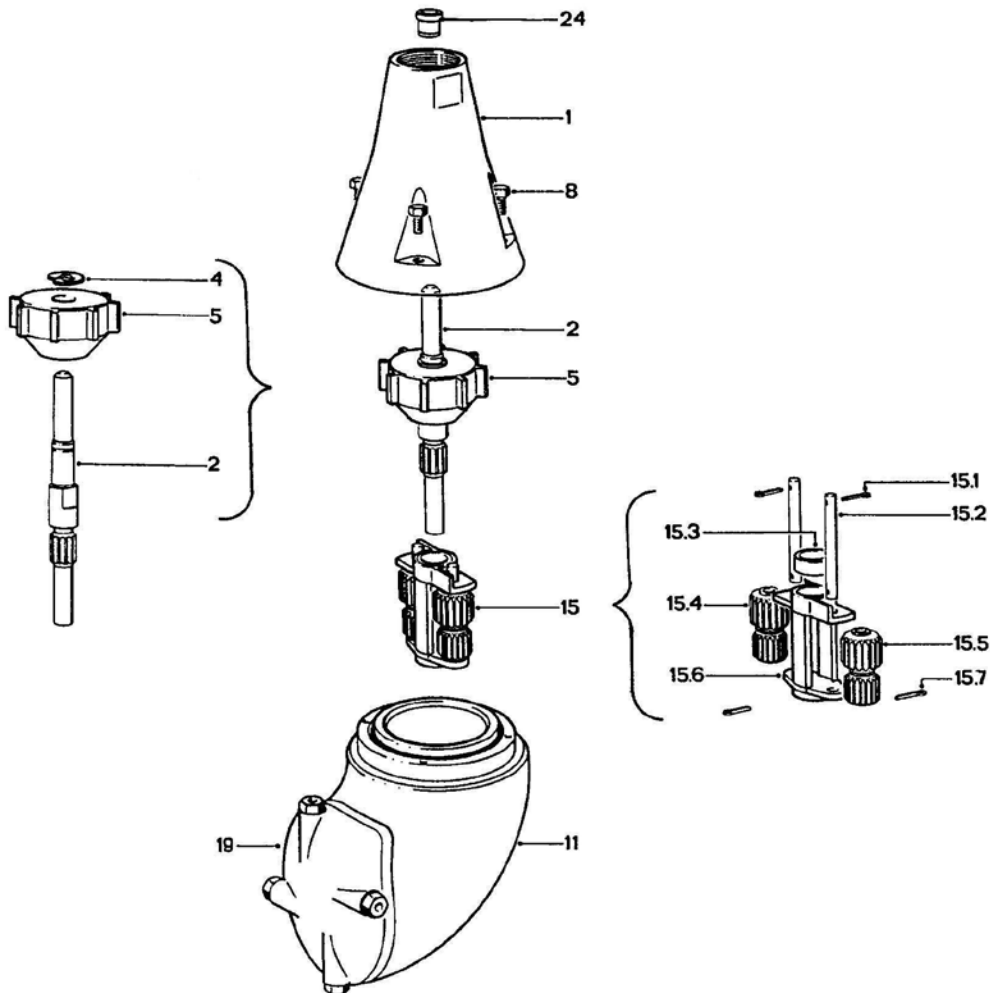

- D1.8 Remove Retainer spring (Pos. 6) – see page 30. Use flathead Screwdriver to lift Retainer spring out of groove in Stem (Pos. 16). Lift off Retaining ring (Pos. 7).
- D1.9 Hold Body against table and unscrew Stem nut w. ball race (Pos. 9) with Caliper (tool No. TE369) – see page 36. If the Stem Nut with Ball Race is difficult to loosen use rubber hammer on Caliper. Withdraw Stem (Pos. 16) together with Ball retainer w. balls (Pos. 10).

D1.10 Remove the 3 Screws (Pos. 12) with a socket wrench (tool No. TE462A) and draw out Internal gear (Pos. 13).

D1.11 Secure the body in Bench vice (NB!!: use cloth between jaws and body to avoid making scratches and imperfections in body surface) so that the hub cover is secured. Insert a 13 mm spanner (tool No. TE81B041) onto cap nut (Pos. 23) and unscrew the Cap nut (Pos. 23) – see page 30 Remove Washer (Pos. 22). IMPORTANT: Inserting drift punch into nozzle (Pos. 21), instead of using the bench vice, to apply resistance for unscrewing Cap nut (Pos. 23), damages the nozzle and the nozzle vane.

D1.12 Hold Body against table and unscrew Hub nut w. ball race (Pos. 18) with Caliper (tool No. TE369) – see page 39. If the Stem nut w. Ball race is difficult to loosen use rubber hammer on Caliper.

<p>Note: Left-hand thread</p>

Withdraw Hub (Pos. 17) together with Ball retainer w. balls (Pos. 10).

D1.13 With flathead screwdriver lift Slide bearing (Pos. 14) and Bearing for Turbine shaft bottom (Pos. 3) out of Body – see page 39.

D1.14 Unscrew Nozzles (Pos. 21) with 11 mm spanner. Be careful not to damage Nozzle vanes (Pos. 20) as this will severely reduce Nozzle performance. Nozzle vanes should not be removed unless they need to be replaced.

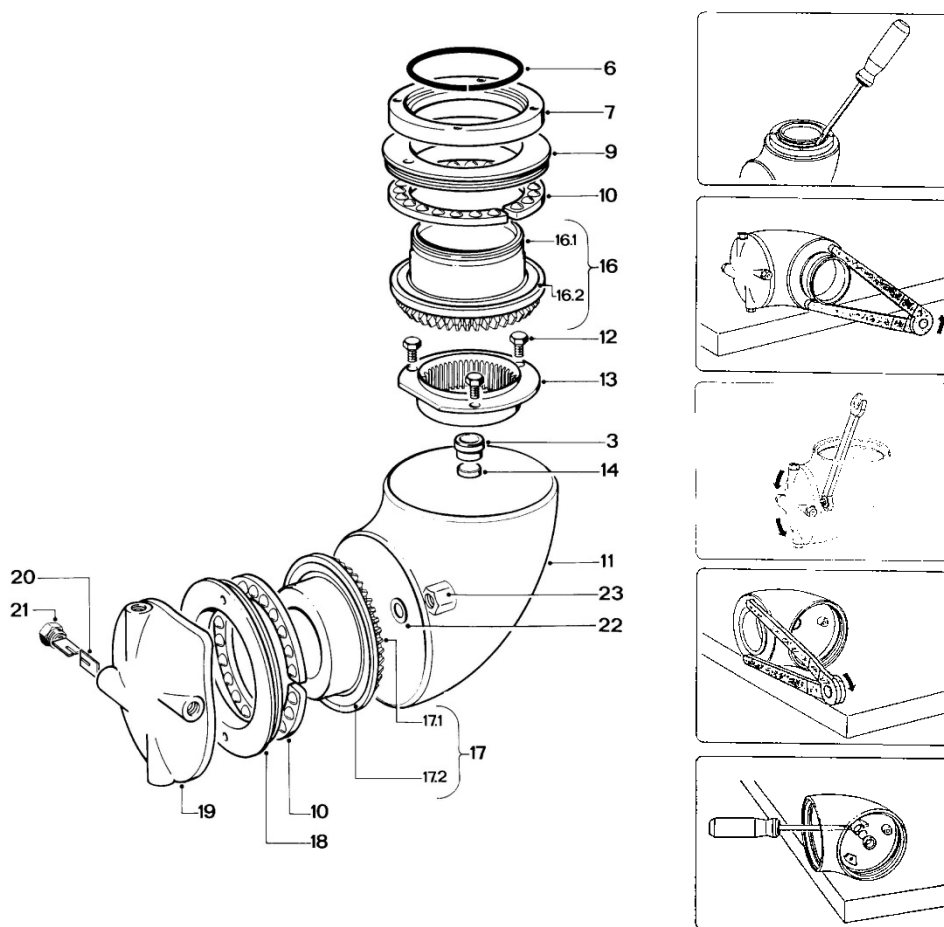

Assembly

Before reassembly, make sure that all parts are clean without deposits or build-up of foreign matter.

Inspect the nozzle vanes for foreign objects (e.g. product pulp, threads, etc.) and if necessary clean with care – damaging nozzles (or fouled nozzles) will decrease the throw length of the machine. Clean using compressed air or tweezers.

- R1.1 Insert Bearing for Turbine shaft top (Pos. 24) in top of Cone (Pos. 1). (Use drift punch to align and make the initial pressure-by-hand into the hole for the bearing. Then push it all the way in using the reverse end of the socket wrench (if needed use rubber hammer to apply pressure)).

Note: The two Planet wheels are different: on Planet wheel 1, teeth of upper and lower gearing are aligned, while they are displaced $\frac{1}{2}$ tooth on Planet wheel 2.

- R1.2 Insert Carrier bearing (Pos. 15.3) and push with thumb. Insert Planet wheels (Pos. 15.4 and 15.5) and Shafts (Pos. 15.2) and secure with Cotter pins (Pos. 15.7) – lock the Cotton pins by bending the ends around the Shafts (Pos. 15.2). Check free rotation of Planet wheels.
- R1.3 Insert Carrier Assembly (Pos. 15), into Body: Hold Body in one hand and use the other to turn Hub Cover (Pos. 19) left and right with small rocking movements until carrier falls through Internal gear (Pos. 13, page 30). Check that carrier is fully home on Bearing for Turbine shaft

bottom (Pos. 3) in Body: Rotate Carrier Assembly by hand a few rotations to check correct position and function. (Hub cover (pos. 19) is now locked and can only rotate by moving the Carrier assembly).

- R1.4 Mount Impeller (Pos. 5) on Turbine shaft (Pos. 2) and secure with Circlip (Pos. 4) using flathead Screwdriver.
- R1.5 Insert Turbine shaft with Impeller through Carrier Assembly. Rotate Impeller to ensure correct insertion into Bearing for Turbine shaft (Pos. 3) in Body. Check unrestricted rotation.
- R1.6 Mount Cone (Pos. 1) over Turbine shaft and Retaining ring. Mount and tighten the 4 Screws (Pos. 8) with Socket wrench (tool No. TE462A).
- R1.7 Place Slide bearing (Pos. 14) in Body and push in Bearing for Turbine shaft (Pos. 3) with thumb (or end of Socket Wrench). Make sure that Bearing is fully home.
- R1.8 Insert Hub (Pos. 17) together with Ball retainer w. balls (Pos. 10). Mount Hub nut w. Ball race (Pos. 18) with Caliper (tool No. TE369) and tighten. The Hub nut w. Ball race should be tightened so much that it cannot be loosened by hand (e.g. use rubber hammer a few times on Caliper to increase torque).

Note: Left-hand thread

- R1.9 Insert Hub cover (Pos. 19) into centre hole of Hub (Pos. 17).
- R1.10 Place Washer (Pos. 22) on threaded pin on Hub cover (Pos. 19) and mount Cap nut (Pos. 23). Insert spanner (tool No. TE81B041) into Body, hold Cap Nut (Pos. 23) and by hand screw on Hub cover (Pos. 19) and tighten to a torque of 25 Nm using torque wrench toolkit (tool. No. TE81087). Check free rotation of Hub.

Warning: Tightening torque: 25 Nm.



Use torque toolkit or alike

- R1.11 Insert Internal gear (Pos. 13), mount Screws (Pos. 12) and tighten with Socket wrench (tool No. TE462A).
- R1.12 Insert Stem (Pos. 16) together with Ball retainer w. balls (Pos. 10). Mount Stem nut w. ball race (Pos. 9) with Caliper (tool No. TE369) and tighten. Turn Hub cover (Pos. 19) and check unrestricted rotation.
- R1.13 Place Retaining ring (Pos. 7) over Stem (Pos. 16) and push on Retainer spring (Pos. 6) and "click" into groove in Stem. Check free rotation.

Replacement of Ball Races

1. Place Stem or Hub completely (Pos. 16 or 17, see page 30) in a support ring (e.g. a piece of pipe with an inner diameter of $\varnothing 84$) and press off Ball race. Press parallel. Be careful not to damage teeth and opposite end face of Stem.

2. With the support ring (e.g. a piece of pipe with an inner diameter of $\varnothing 84$) press Ball race fully home. Press parallel. Be careful not to damage surface of Ball race.

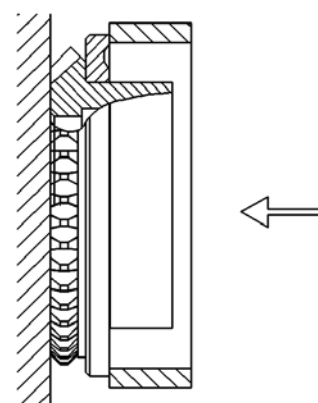
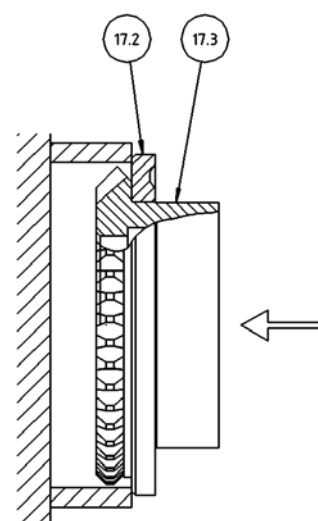

Trouble Shooting Guide

Symptom: Loose Nozzle Hub

Possible Causes	Fault finding
Loose Cap nut	a). Check that the torque of the Cap nut (Pos. 23) is at least 25 Nm.
Wear	b). Remove Cap nut (Pos. 23) and check Washer (Pos. 22) for wear and signs of corrosion – replace if needed.

Symptom: Slow rotation or failure of machine to rotate

Possible Causes	Fault finding
No or insufficient liquid flow	<p>a). Check if supply valve is fully open.</p> <p>b). Check if inlet pressure to machine is correct.</p> <p>c). Check supply line/filter for restrictions/clogging.</p> <p>d). Remove Nozzles and check for clogging. If blocked, carefully clean Nozzle without damaging Nozzles vanes and Nozzle tip.</p> <p>e). Remove Cone (see page 37) and check for clogging in Impeller of inlet guide inside Cone and in Impeller area.</p> <p>If large particles repeatedly get jammed in the machine, install filter or reduce mesh size of installed filter in supply line.</p>
Foreign material or material build-up	<p>Insert Screwdriver in Screw in top of Turbine shaft and easily turn Turbine shaft clockwise. If any resistance is recognised, disassemble machine to localise cause.</p>
f). Impeller jammed	Remove Turbine shaft with Impeller and Carrier assembly (see page 37) and remove foreign material.
g). Turbine shaft sluggish in Bearings	Remove Turbine shaft with Impeller (see page 37) and clean Bearings.
h). Planet gear jammed/sluggish	Remove foreign material from Planet wheels and internal gears. Check rotation of Planet wheels. If restriction is recognised, disassemble Carrier assembly (see page 37) and remove material build up, especially on Shafts and bushes in Planet wheels.

Symptom: Slow rotation or failure of machine to rotate (continued)

Possible Causes	Fault finding
i). Stem or Hub jammed/sluggish	Remove Carrier assembly (see page 37). Turn Hub cover and check unrestricted rotation. Remove Stem and Hub (see page 38). Remove foreign material/ material build-up on Stem, Hub and inside Nut w. ball race. Clean Ball races and Ball retainer with balls. Assemble Stem/Hub, Ball retainer with balls and Stem/Hub nut with ball race.
j). Bevel gears jammed	Remove Stem and Hub (see page 38). Clean teeth on Stem and Hub.

Wear

k). Slide bearings	See page 26.
l). Bearing for Turbine shaft	See page 26.
m). Planet wheels	See page 26.
n). Shafts for Planet wheels	Check clearance of Planet wheels on Shafts. Transverse movement should not exceed 0.3 mm.
o). Turbine shaft	Check clearance in Carrier bearing and Bearing for Turbine shaft. Transverse movement should not exceed 0.3 mm. Also inspect teeth for wear.

Mechanical defects

p). Planet wheels. Teeth broken	Replace Planet wheels.
q). Planet wheel cannot rotate on Shafts/ Shafts bent.	Replace Shafts for Planet wheels.
r). Damaged teeth on Bevel gear	Inspect teeth on Stem and Hub for deformation. Mount Hub and Stem in Body (See page 39). Hold Body in upside down position and rotate Hub to check that bevel gears can work together. If damaged: Replace Stem and/or Hub.
s). Damage on Stem and Hub-nut	If hard particles get stuck between Stem nut and Stem or Hub nut and Hub, the particles will damage the parts. The damaged parts should be replaced.

How to Order Spare Parts

On the Part List Drawing page 30 as well as on all instruction drawings, the individual parts have a position number, which is the same on all drawings. From the position number, the part is easily identified in the Reference List of Parts, page 31. Individual parts should always be ordered from the Reference Lists of Parts, clearly stating reference number and description.

Please also quote the type of machine and serial no. This will help us to help you. The serial no. is stamped on the housing of the tank cleaning machine.

In cases where spare parts are ordered for machines originally delivered with 3.1 certificates, please state this information on your ordering form together with the machine type and serial number. This is to ensure full traceability henceforward.

In connection with ordering of spare parts for machines originally delivered with Q-doc (Qualification Documentation) please note that all service and repair should be performed by Alfa Laval Kolding A/S, Kolding, Denmark, see page 25 "Service and Repair of machines ordered with Q-Doc".

How to contact Alfa Laval Tank Equipment

For further information please feel free to contact:

Alfa Laval Tank Equipment

Alfa Laval Kolding A/S

31, Albuen - DK 6000 Kolding - Denmark

Registration number: 30938011

Tel switchboard: +45 79 32 22 00 - Fax switchboard: +45 79 32 25 80

www.toftejorg.com , www.alfalaval.dk - info.dk@alfalaval.com

Contact details for all countries are continually updated on our websites.

Instruction Manual – Misc.

Misc. - Contents

EU Declaration of Conformity incl. ATEX.....	46
Declaration of Conformity, EN 10474, sub clause 2.2 Test Report	47
ATEX-Special Conditions for safe use	49
Declaration of Compliance with 10/2011 – Food contact materials	50

EU Declaration of Conformity incl. ATEX

EC Declaration of Conformity

Revision of Declaration of Conformity: 2014-06-10

The designated company

Alfa Laval Kolding A/S
Company name

Albuen 31, 6000 Kolding, Denmark
Address

+45 79 32 22 00
Phone no.



hereby declare that

Tank Cleaning Machine
Denomination

Toftejorg TJ20G
Type

From serial numbers from 2015-00001 to 2030-99999

is in conformity with the following regulations and directives with amendments:

- **FDA 21CFR§177 and 174.6**
- **The Machinery Directive 2006/42/EC**
DS/EN ISO 12100:2011
- **The Regulation (EC) 1935/2004**
- **The Pressure Directive 97/23/EC**
According to its own volume and the rated pressure range the product is regarded an Article 3, paragraph 3 Equipment
- **The Equipment Explosive Atmospheres (ATEX) Directive 94/9/EC**
(Applicable for machine certified as category 1 and 2 component, see machine engraving)
*DS/EN 13463-1:2009, DS/EN 13463-5:2011,
DS/EN ISO/IEC 80079-34:2011, Annex A, paragraph A.5.3 Rotating machines*
EC Type Examination Certificate no. Baseefa04ATEX0358X
Marking:  II 1 GD c T140°C
Marking:  II 1 GD c T250°C Tamb 0°C to 0 200°C (f. 20G016,017,018-7x/8x)
*Baseefa Ltd., Certification body number 1180, Rockhead Business Park
Staden Lane, Buxton, Derbyshire SK17 9RZ, United Kingdom*

The person authorised to compile the technical file is the signer of this document.

QHSE Manager, Quality, Health
and Safety & Environment
Title

Annie Dahl
Name

Signature

ATEX Responsible Engineer
Title

Denniz Høxbroe
Name

Signature

2015-01-01
Date

Kolding
Place



Declaration of Conformity, EN 10474, sub clause 2.2 Test Report



**Declaration Of Conformity
with
EN 10204, Sub Clause 2.2 Test Report
Materials of Construction and Surface Finishes**

Alfa Laval Kolding A/S (supplier)

declare, under our sole responsibility, that the following product:

Description
Toftejorg TJ20G Rotary Jet Head

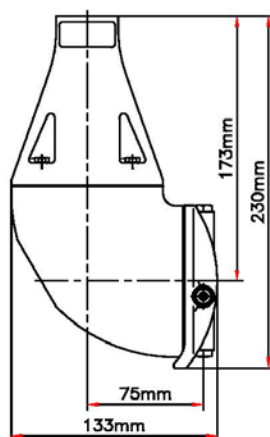

has been subjected to non-specific controls for product quality and are found to conform with the following standards and other normative documents:

Metal Materials

AISI 316	Werkstoff No. 1.4401
AISI 316L	Werkstoff No. 1.4404
SAF 2205	Werkstoff No. 1.4462
A4	

For Hastelloy machines:

Hastelloy C22	Werkstoff No. 2.4602
Hastelloy C276	Werkstoff No. 2.4819

1 of 2

This certificate is delivered in compliance with the latest valid design and construction. Alfa Laval Kolding A/S reserve the right to alter or modify any unit specification without notice or any obligation.
Rev. 1. 20140314

Declaration of Conformity, EN 10474, sub clause 2.2 Test Report

Non-Metal Materials

21CFR§177.1550 (PTFE)
21CFR§177.2600 (EPDM)

21CFR§177.2510 (PVDF)
21CFR§177.2415 (PEEK)

Surface Finish

All parts are finished with a nominal external roughness Ra = 0.8 µm (30 micro inch).

Non-Specific Controls on Product Quality "As-Supplied"

All metallic part material certifications are inspected upon receipt before assembly.

Parts inspections are completed according to the approved ISO 9001:2008 standard program. The Quality Control Department only accepts the product in component parts for assembly according to this program if the parts comply with the above material specification documentation.

Product welds are executed, inspected and finished (polished where accessible), according to written, approved procedures.

Parts produced from FDA approved polymers are only sourced from suppliers that have met "pre-qualification" standards established by Alfa Laval Kolding's ISO 9001:2008 program. Materials of construction of component parts are controlled through clear and explicit specifications in purchase orders. These specifications include the materials of construction specified by the parts designers, making them subject to the contractual terms and conditions.

The following item numbers are covered by this certificate:

TE20G000(-xx)	TE20G002(-xx)	TE20G004(-xx)
TE20G010(-xx)	TE20G012(-xx)	TE20G014(-xx)
TE20G016-x2	TE20G017-x2	TE20G018-x2
TE20G020(-xx)	TE20G022(-xx)	TE20G024(-xx)
TE20G030(-xx)	TE20G032(-xx)	TE20G034(-xx)
TE20G040(-xx)	TE20G042(-xx)	TE20G044(-xx)
TE20G050(-xx)	TE20G052(-xx)	TE20G054(-xx)
TE20H000(-xx)	TE20H002(-xx)	TE20H004(-xx)
TE20H020(-xx)	TE20H022(-xx)	TE20H024(-xx)
TE20H050(-xx)	TE20H052(-xx)	TE20H054(-xx)

no postfix: PVDF impeller (PEEK impeller for TE20Hxxx)	-7X: ATEX
-x2: PEEK impeller	-8X: 3.1 cert. + ATEX
	-9X: 3.1 cert

Copenhagen, Ishøj, on March 18, 2014
For Alfa Laval Kolding A/S



Annie Dahl
Quality Manager

2 of 2

This certificate is delivered in compliance with the latest valid design and construction. Alfa Laval Kolding A/S reserve the right to alter or modify any unit specification without notice or any obligation.
Rev. 1. 20140314

ATEX-Special Conditions for safe use

ATEX CERTIFICATION

EC – Type Examination Certificate Number : Baseefa04ATEX0358X

II 1GD c T140°C

II 1GD c T250°C Tamb -0°C to +200°C

BASEEFA CUSTOMER REFERENCE No. 5322

PROJECT FILE No. 10/0610

Special Condition for Safe Use

1. The Unit may be operated, only when filled with fluid.
2. The maximum permitted process fluid temperature is 95°C, with an ambient temperature range of 0°C to +140°C for standard units and 0°C to +200°C for Hi-temperature units.
3. The maximum permitted process fluid pressure is 8 bar.
4. The unit must not be operated in a tank/vessel having an enclosed volume of greater than 100m³.
5. The unit must be effectively earthed at all times when in use.

This product fully complies to ATEX category 1 as long as the 5 special conditions above are adhered to.

Please read the above conditions prior to installation & ensure that all conditions are met.

Explanation of T (temperature) rating.

The ATEX classification

The standard machines is approved for an ambient temperature range of 0°C to +140°C and is marked

II 1GD c T140°C

Hi-temperature machines is approved for an ambient temperature range of 0°C to +200°C.

“T250°C” means that the machine is approved with a safety margins of 25% and is marked

II 1GD c T250°C Tamb -0°C to +200°C

Declaration of Compliance with 10/2011 – Food contact materials

Declaration of compliance for food contact materials



Article Nr: TE20Gxx-xx

Product TJ20G

We, Alfa Laval Kolding A/S, hereby certify that the plastic articles intended to come into contact with product included in the article stated above comply with the Regulation (EC) No. 1935/2004 and the Regulation (EC) No. 10/2011 both in their relevant versions on materials and articles intended to come in contact with food.

Finished articles subject to an overall migration limit of 10 mg/dm² or 60 mg/kg. The following substances subject to limitations are used in the above stated article: SML:

PEEK 450G (PEEK GLD FG 140)
Diphenylsulphor: 3 mg/kg food
1,4 Dihydroxybenzol: 0.6 mg/kg food
4,4' Defluorobenzopheneone: 0.05 mg/kg food
(TFE: 0.05 mg/kg/kg food)

PFA and PTFE
TFE: 0.05 mg/kg food
PPVE: 0.05 mg/kg food

PVDF
VDF: 5 mg/kg food
Antioxydant: 5 mg/kg food

Migration from the plastic articles has been investigated by calculations as laid down in paragraph (32) in Regulation (EC) No. 10/2011, to control that the migration limits and other requirements are fulfilled. The articles can be used, within its application area, with all type of foods at batch size above 1,500 kg*.

We also certify that the plastic articles intended to come into contact with product included in the article stated above are also entirely in accordance with the present US regulation FDA CFR 21§ 177.

Ishøj, 10-06-2014

A handwritten signature in blue ink, appearing to read 'Henrik Falster-Hansen'.

Henrik Falster-Hansen,
R&D Manager
Alfa Laval Kolding A/S

*Based on worst case scenario = all of the free monomer in the plastic migrates to one batch.

Alfa Laval Kolding A/S
Albuen 31, DK-6000 Kolding
Tel switchboard: +45 79 32 22 00 - Fax switchboard: +45 79 32 25 80
www.alfalaval.com

How to contact Alfa Laval

Contact details for all countries are continually updated on our website.

Please visit www.alfalaval.com to access the information directly.

© Alfa Laval Corporate AB

This document and its contents is owned by Alfa Laval Corporate AB and protected by laws governing intellectual property and thereto related rights. It is the responsibility of the user of this document to comply with all applicable intellectual property laws. Without limiting any rights related to this document, no part of this document may be copied, reproduced or transmitted in any form or by any means (electronic, mechanical, photocopying, recording, or otherwise), or for any purpose, without the expressed permission of Alfa Laval Corporate AB. Alfa Laval Corporate AB will enforce its rights related to this document to the fullest extent of the law, including the seeking of criminal prosecution.