



Alfa Laval GJ A6

Rotary jet heads

Introduction

The Alfa Laval GJ A6 is a rotary jet head tank cleaning machine for use in hygienic environments. Built to clean tanks from 6-20 feet in diameter and up to 20 feet tall, it combines pressure and flow to create high-impact cleaning jets that rotate in a repeatable and reliable 360-degree cleaning pattern.

The GJ A6 minimizes the consumption of water and cleaning media. Easy to customize to meet customer requirements, it allows companies to spend less time cleaning and more time producing.

Applications

The Alfa Laval GJ A6 is designed for the removal of the toughest residues from hygienic tanks across a broad range of industries, such as the dairy, brewery, beverage, food, and personal care industries.

Due to its slim design, the GJ A6 is ideal to retrofit spray balls, thereby reducing Cleaning-in-Place (CIP) costs and cleaning time.

Benefits

- 60% faster cleaning = more time for production
- Saves up to 70% of your cleaning cost
- High-impact cleaning in a 360° repeatable cleaning pattern
- Cleaning process can be validated using Alfa Laval Rotacheck
- Slim design makes it possible to insert through small tank inlet openings

Standard design

The choice of nozzle diameters can optimize jet impact length and flow rate at the desired pressure.

Alfa Laval offers a wide range of tank cleaning machines suitable for different duties and industries.

An alternative that offers performance similar to the Alfa Laval GJ A6 is the Alfa Laval SaniJet 20, which offers a more hygienic design and an electropolished Ra 0.5 surface finish. The SaniJet 20 is ideal for applications that require 3.1 material certification, ATEX certification, and smooth qualification and validation



processes through the Alfa Laval Q-doc documentation package.

Working principle

The high-impact jet stream from the Alfa Laval GJ A6 rotary jet head cover the entire surface of the tank interior in a successively denser pattern. This achieves a powerful mechanical impact with a low volume of water and cleaning media.

The flow of the cleaning fluid makes the nozzles perform a geared rotation around the vertical and horizontal axes. In the first cycle, the nozzles lay out a course pattern on the tank surface. The subsequent cycles gradually make the pattern denser until at full cleaning pattern is reached. Once the full cleaning pattern is reached, the machine will start over again and continue to perform the next full cleaning pattern.

Cleaning Pattern

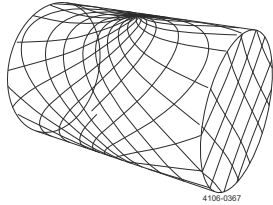

First Cycle

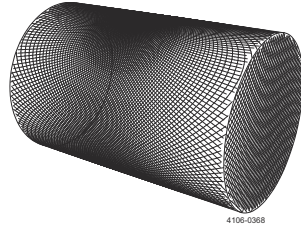

Full Pattern

The drawings show the cleaning pattern achieved on a cylindrical horizontal vessel. The difference between the first cycle and the full pattern represents the number of additional cycles available to increase the density of the cleaning.

Certificate

2.1 material certificate



TECHNICAL DATA

Lubricant:	Lubricated with cleaning fluid
------------	--------------------------------

Throw length

Max. throw length:	6-20 ft
--------------------	---------

Pressure

Working pressure:	30-150+ PSI
Recommended pressure:	60-150 PSI

PHYSICAL DATA

Materials

1.4404 (316L), PEEK¹, EPDM¹ (FKM¹ and FFKM¹), PPS¹

¹ FDA compliance 21CFR§177

Temperature

Max. working temperature:	203 °F
Max. ambient temperature:	284 °F

Weight

Weight	4 lbs
--------	-------

Surface finish

Surface finish:	32 µin
-----------------	--------

Connections

Standard inlet connection:	1" US BPE SCH 5/IDØ25,7 Clip-on DN25 Clip-on DIN 11850 range 1 DN25 Clip-on DIN 11850 range 2
Available option:	1½" ASME BPE Weld-on ¾" FNPT thread with external 1" male camlock

Caution

Avoid hydraulic shock, hard and abrasive particles in the cleaning liquid, as this can cause increased wear and/or damage of internal mechanisms. In general, a filter in the supply line is recommended. Do not use for gas evacuation or air dispersion. For steaming we refer to the manual.

Pressure Flow – 2 Nozzles

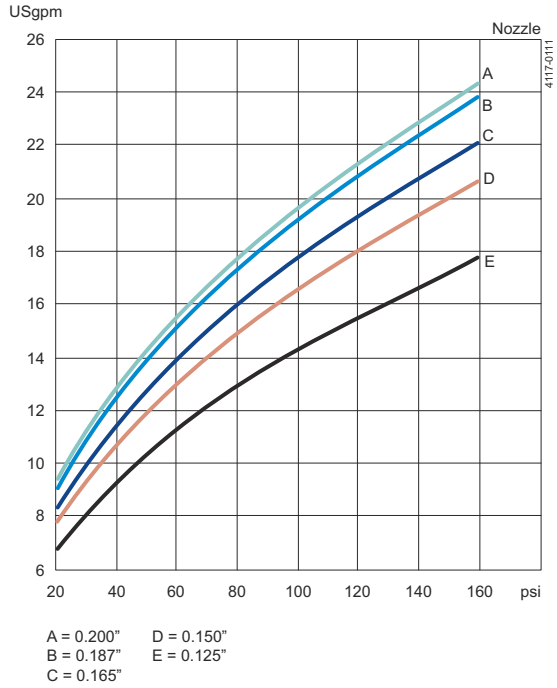

Pressure Flow – 3 Nozzles

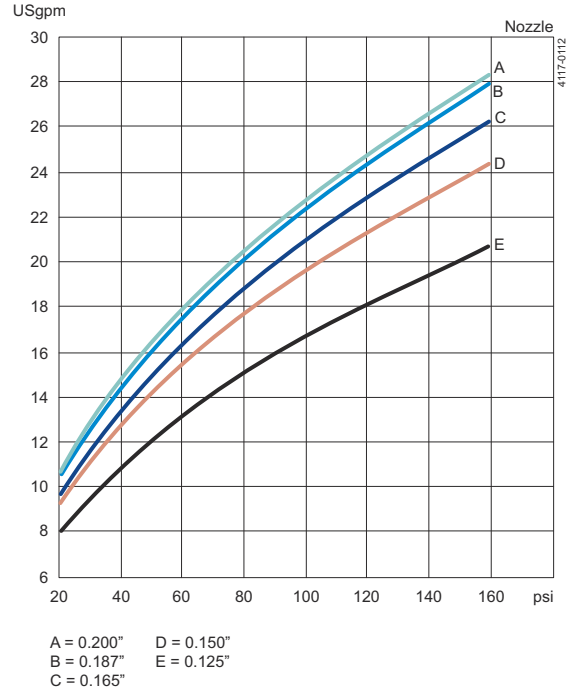

Throw Distance – 2 Nozzles

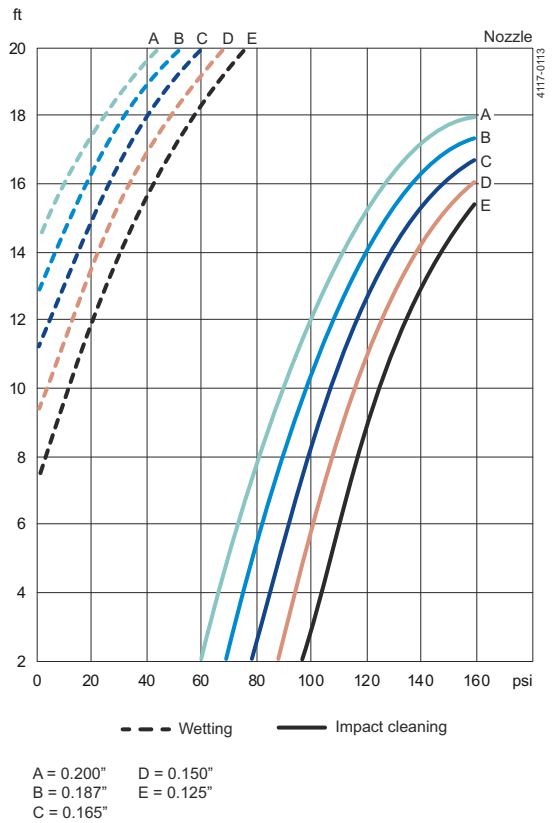

Throw Distance – 3 Nozzles

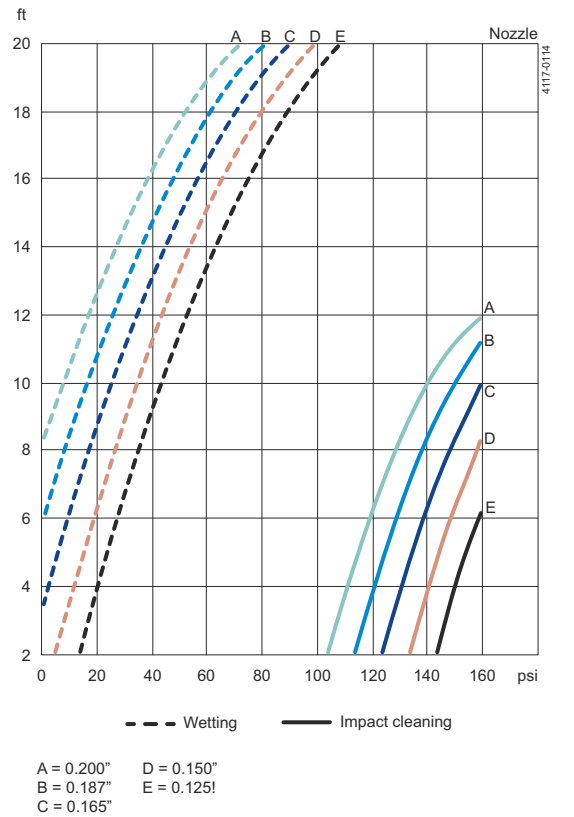

Flow Rate Cycle Time

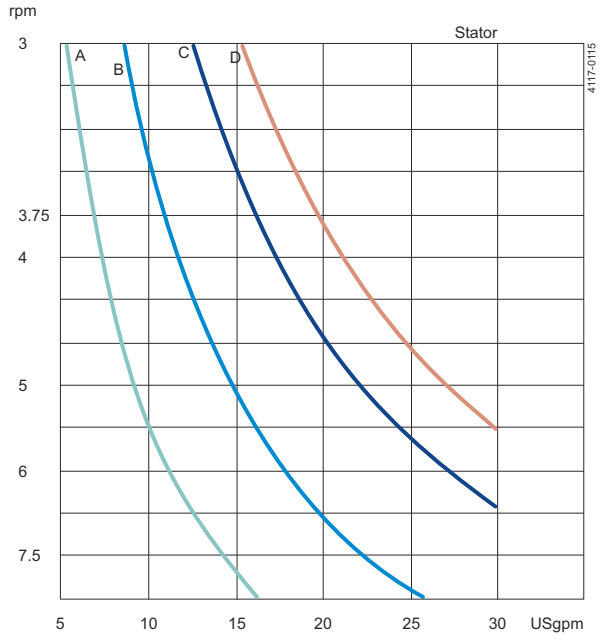

A = LV D = HV
B = STD
C = MV

Dimensions (inch)

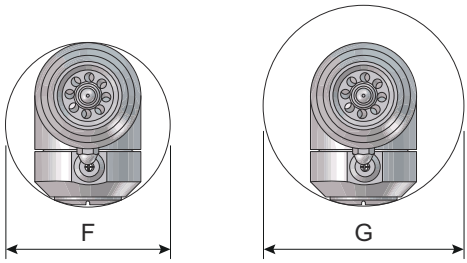
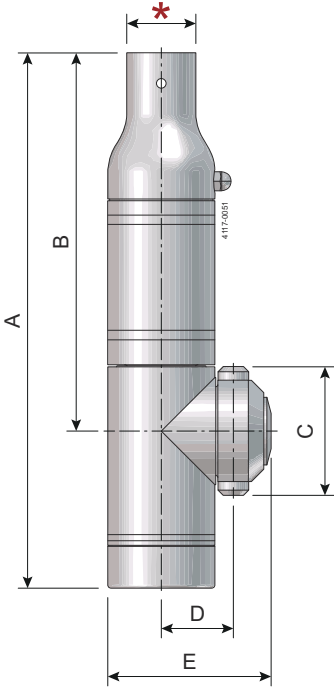

NOTE *: 1" R-CLIP COLLAR OR 1-1/2" BUTT WELD

A	B	C	D	E	F	G
8.75	6.19	2.1	1.18	2.67	2.72	3.64

TRAX simulation tool

TRAX is a unique software that simulates how the Alfa Laval GJ A6 performs in a specific tank or vessel. The simulation gives information on wetting intensity, pattern mesh width and cleaning jet velocity. This information is used to determine the best location of the tank cleaning device and the correct combination of flow, time, and pressure to implement. A TRAX demo containing different cleaning simulations covering a variety of applications can be used as a reference and documentation for tank cleaning applications. The TRAX demo is free and available upon request.

Wetting Intensity

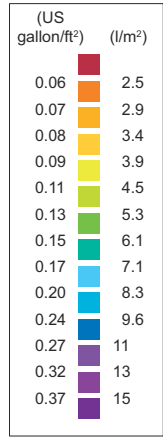

4106-0389

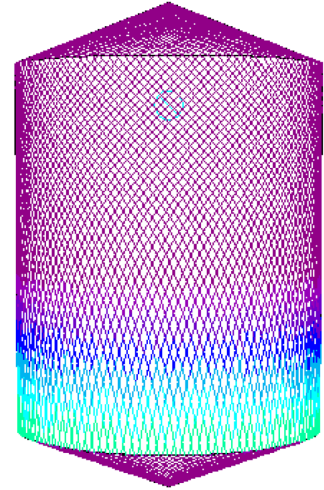
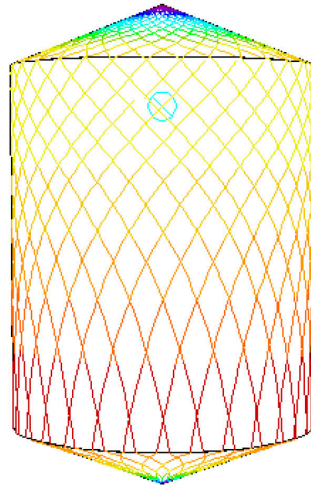

D118 in, H189 in, 2 x Ø187, time 3.25min D118 in, H189 in, 2 x Ø187, time 13min

This document and its contents are subject to copyrights and other intellectual property rights owned by Alfa Laval Corporate AB. No part of this document may be copied, re-produced or transmitted in any form or by any means, or for any purpose, without Alfa Laval Corporate AB's prior express written permission. Information and services provided in this document are made as a benefit and service to the user, and no representations or warranties are made about the accuracy or suitability of this information and these services for any purpose. All rights are reserved.

200006875-1-EN-US

© Alfa Laval Corporate AB

How to contact Alfa Laval

Up-to-date Alfa Laval contact details for all countries are always available on our website at www.alfalaval.com