



Alfa Laval Unique Mixproof

Double seat valves

Introduction

The Alfa Laval Unique Mixproof Valve is a versatile, highly flexible double block-and-bleed valve for the safe and efficient management of fluids at intersection points in matrix piped systems. The valve enables the simultaneous flow of two different products or fluids through the same valve without the risk of cross-contamination. Modular design and a wide variety of options enable the valve to be customized to meet any process requirement—whether higher demands on cleanability and the ability to withstand pressure peaks.

Application

The Alfa Laval Unique Mixproof is designed for continuous flow management and process safety in hygienic processes where product safety is at the top of the agenda across the dairy, food, beverage and many other industries.

Benefits

- Enhanced product safety
- Cost-effective, spillage-free operation
- Optimized plant efficiency and enhanced cleanability
- Leakage detection and leakage chamber cleaning
- Fully configurable to fit your exact needs

Standard design

The Alfa Laval Unique Mixproof Valve is comprised of a series of base components, including valve body, valve plug, actuator, and cleaning options and accessories that support a wide range of applications. There are four pre-configured versions: the Unique Mixproof Basic; the Unique Mixproof SeatClean Valve; the Unique Mixproof HighClean Valve; and the Unique Mixproof UltraClean Valve. Leakage detection holes enable visual inspection without requiring valve disassembly and provide advance notification of parts wear. Few straightforward moveable parts contribute to reliable operation and reduced maintenance costs. The valve can also be fitted with the Alfa Laval ThinkTop V50 and V70 for sensing and control of the valve.

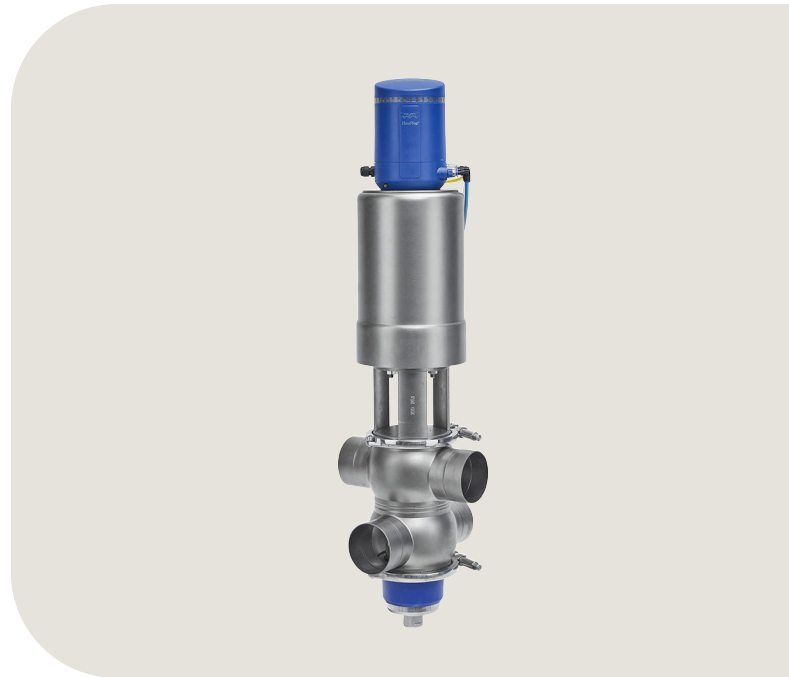

Working principle

The Alfa Laval Unique Mixproof Valve is a normally closed (NC) valve controlled from a remote location by means of compressed air. The valve has two independent plugs and seals to separate the liquids; the space between the seals forms a leakage chamber at atmospheric pressure during every working condition. Leakage rarely occurs but, should it occur, product flows into the leakage chamber and exits through the bottom outlet for easy detection.

When the valve is open, the leakage chamber is closed. The product then flows from one line to the other. The radial design of the valve ensures that virtually no product spillage occurs during valve operation. It is possible to adapt valve cleaning and water hammer protection to the requirements of individual process specifications.

Certificates

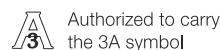

TECHNICAL DATA

Pressure

| | |
|------------------------|-------------|
| Max. product pressure: | 145 psi |
| Min. product pressure: | Full vacuum |
| Air pressure: | 116 psi |

Temperature

| | |
|--------------------|---|
| Temperature range: | 23°F to +257°F (Depending on seal material) |
|--------------------|---|

ATEX

| | |
|-----------------|-----------------------|
| Classification: | II 2 G D ¹ |
|-----------------|-----------------------|



Note! In order to use Unique Mixproof valves in ATEX environment, the blue plastic cover at lower plug must be removed for the valve types where the valve is delivered with the cover mounted

¹ This equipment is outside the scope of the directive 2014/34/EU and must not carry a separate CE marking according to the directive as the equipment has no own ignition source

PHYSICAL DATA

Materials

| | |
|-----------------------------|---------------|
| Product wetted steel parts: | 1.4404 (316L) |
| Other steel parts: | 1.4301 (304) |

Surface finish choose from the following:

| | |
|-------------------------------------|----------|
| Internal/external semi-bright | Ra<64µin |
| Internal Bright (polished) | Ra<32µin |
| Internal/external Bright (polished) | Ra<32µin |



Note! The Ra values are only for the internal surface.

| | |
|-----------------------|------|
| Product wetted seals: | EPDM |
|-----------------------|------|

Other seals:

| | |
|-----------------|------|
| CIP seals: | EPDM |
| Actuator seals: | NBR |
| Guide strips: | PTFE |

Valve body combination

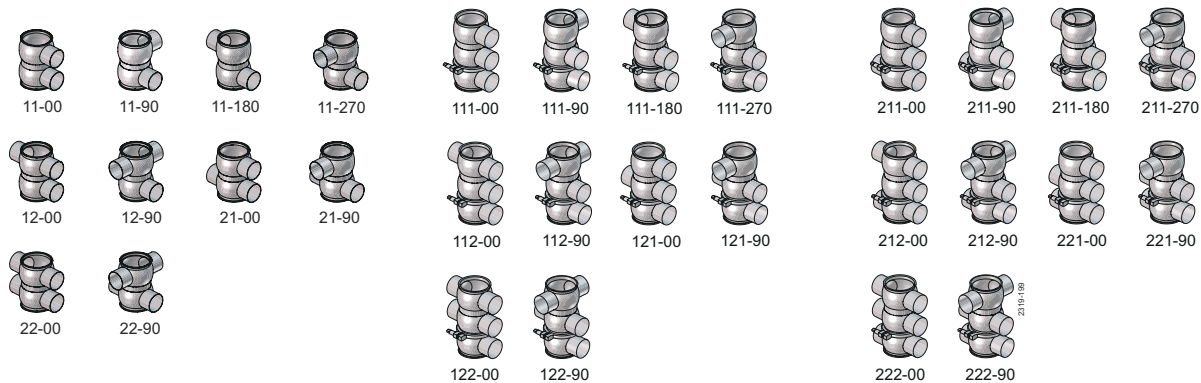

Valve body combinations, example: type 11-00

- 1 Number of ports - lower valve body
- 1 Number of ports - middle valve body
- 1 Number of ports - upper valve body
- 00 Angle between

SpiralClean

The Alfa Laval SpiralClean system to clean the upper and lower balanced plugs and leakage chamber. The system cleans more efficiently, uses less cleaning fluid by ensuring that a directional flow of CIP fluid reaches all the surfaces in much less time than with conventional systems.

Selection guide

The drawings below give an overview of all options when choosing the valve to fit your process, thus demonstrating the actual flexibility of the Unique Mixproof Valve.

Size flexibility

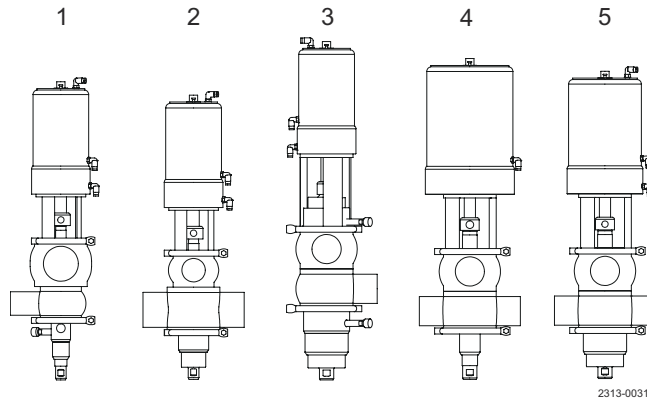

The Unique Mixproof concept offers balanced and unbalanced plugs, seat lift, CIP for the plugs and leakage chambers and any combination in between.

1. ISO 51 (2")/ISO 76.1 (3"), 11-90, with spiral clean on lower unbalanced plug, group 3 basic actuator incl. seat lift and seat push
2. ISO 76.1(3")/ISO 51 (2"), 22-90, with lower balanced plug, basic actuator incl. seat lift and seat push
3. ISO 63.5 (2½"), 12-90, with SpiralClean of upper, lower spindle and leakage chamber, upper and lower balanced plug, basic actuator incl. seat lift and seat push
4. ISO 63.5 (2½"), 22-90, with spiral clean on leakage chamber, unbalanced plugs, group 5 basic actuator
5. ISO 63.5 (2½"), 22-90, with lower balanced plug, group 4 basic actuator incl. seat lift and seat push

Balancing flexibility

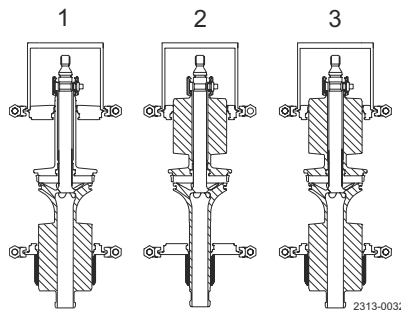

1. Lower balanced plug
2. Upper balanced plug
3. Upper and lower balanced plugs

Hygienic flexibility (spiral clean options)

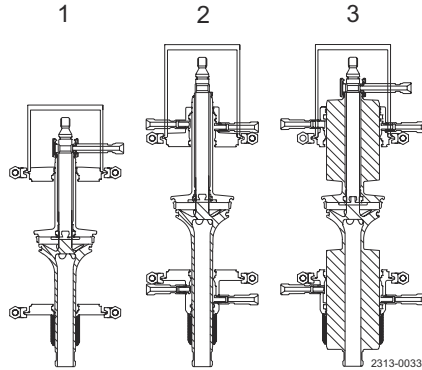

1. External CIP of leakage chamber
2. External CIP of upper and lower unbalanced plug
3. External CIP of leakage chamber upper and lower balanced plug

Standard configurations

To assist you in the selection we have included some standard configurations:

- Unique Basic
- Unique SeatClean
- Unique HighClean
- Unique UltraClean

You can either choose these directly or add additional features ensuring that the valve suits your specific needs.

Unique Basic has the basic components, providing significant safety and leakage detection.

- Actuator without seatlift.
- Unbalanced plugs.
- No SpiralClean of leakage chamber or plugs.
- Not applicable for 3-body version

Unique SeatClean meets the typical demands of a process valve in the food and drink industry.

- Actuator with seat lift integrated.
- Balanced lower plug, Unbalanced upper plug.
- No SpiralClean of leakage chamber or plugs.

Unique HighClean is sure to meet your processing needs when dealing with sticky products or if no recontamination can be accepted at all.

- Actuator without seatlift integrated.
- Balanced lower and upper plug.
- SpiralClean of leakage chamber as well as of upper and lower plug.
- Not applicable for 3-body version.

Unique UltraClean meets the highest demands for hygienic processing. It has:

- Actuator with seat lift integrated.
- Balanced lower and upper plug.
- SpiralClean of leakage chamber, upper and lower plug

Options

- Male parts or clamp liners in accordance with required standard.
- Control and Indication: IndiTop, ThinkTop or ThinkTop Basic.
- Side indication for detection of upper seat lift
- Product wetted seals in HNBR, NBR or FPM
- Various internal/external surface finish
- 3A (hygienic standard) on request
- Mixed housing (Not applicable for 3-body version)

Pressure drop/capacity diagrams

Example to determine pressure drop:

| | |
|------------------|--|
| Upper body size: | 2". Balanced upper plug. Capacity = 80 gpm |
| Lower body size: | 3". Balanced lower plug. Capacity = 80 gpm |
| Between bodies: | Capacity = 60 gpm |

Result:

From fig. 1, $\Delta p = 0.9$ psi through upper body.

From fig. 2, $\Delta p = 0.25$ psi through lower body.

From fig. 3, $\Delta p = 1.7$ psi seeing that:

1. The smallest body determines the curve for Δp between bodies.
2. Always choose the curve for balanced plugs if upper plug is balanced. If only lower plug is balanced, always choose the curve for unbalanced.

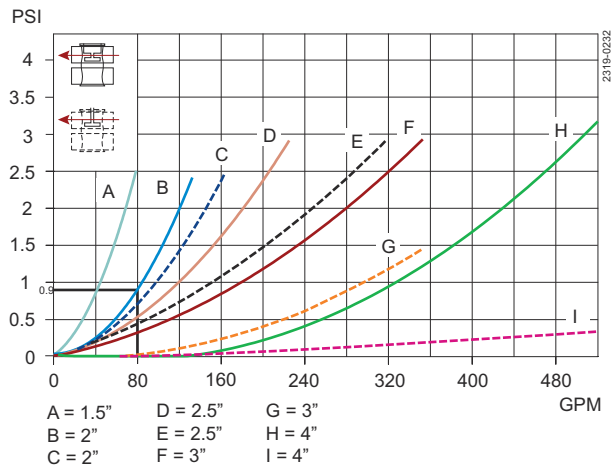

Figure 1. Pressure drop/capacity diagram, upper body.

Full lines: Balanced upper plug.

Dotted lines: Unbalanced upper plug.

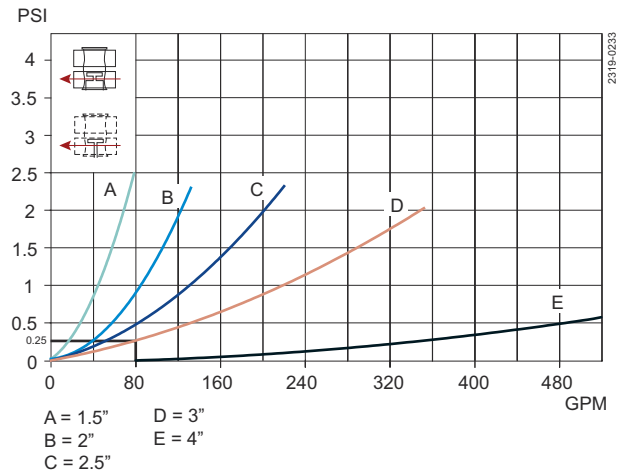

Figure 2. Pressure drop/capacity diagram, lower body, balanced and unbalanced lower plugs.

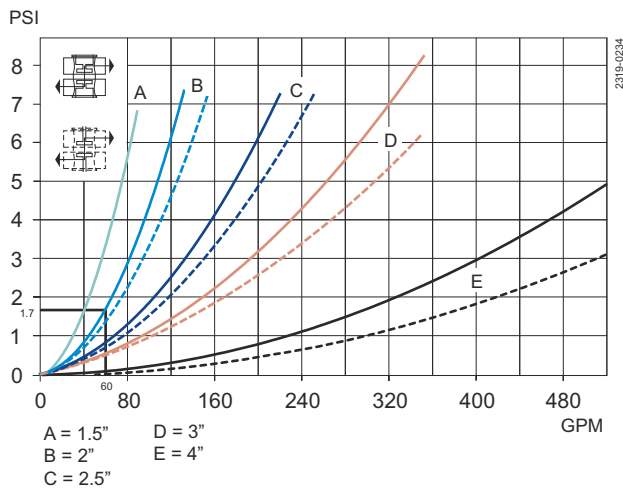

Figure 3. Pressure drop/capacity diagram, between bodies.

Full lines: Balanced.

Dotted lines: Unbalanced.



Note! For the diagrams the following applies:

- Medium: Water (68°F).
- Measurement: In accordance with VDI 2173.

Pressure drop/capacity diagrams for 3 body valve

Between middle and lower body

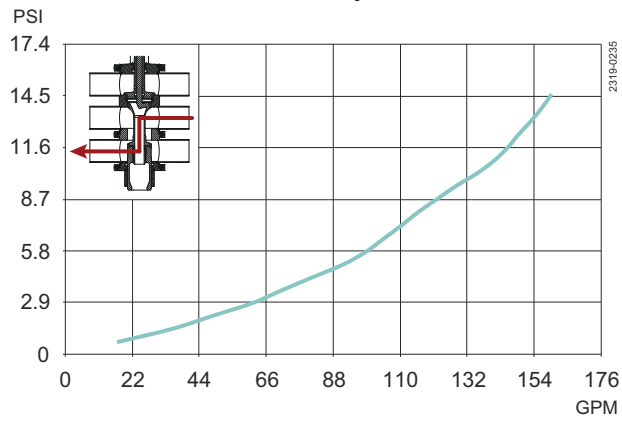

Between middle and upper body

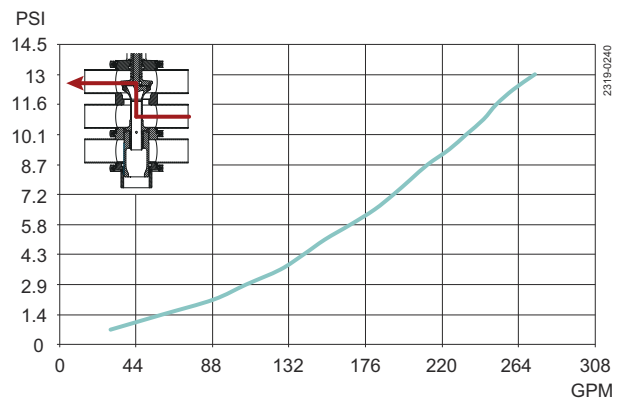
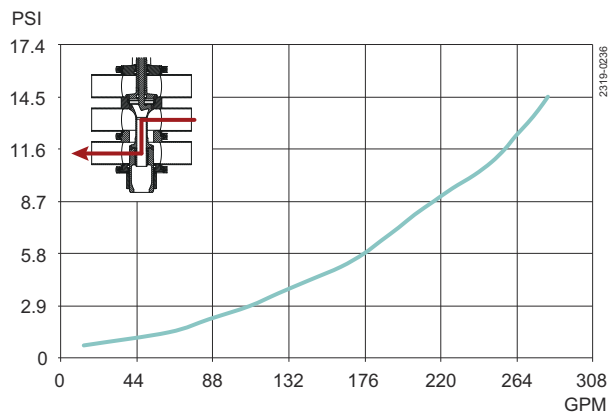
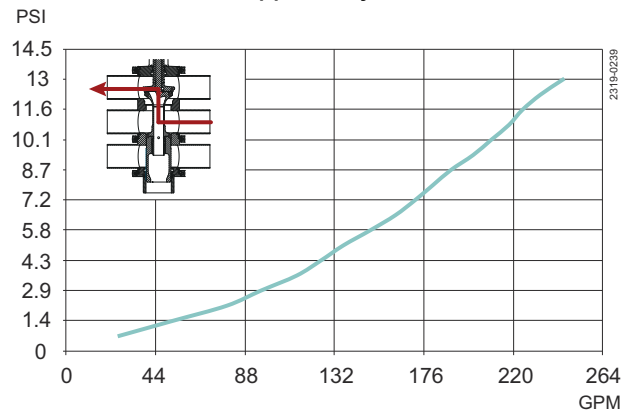

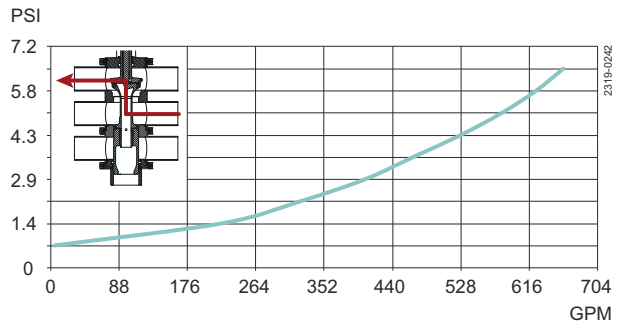
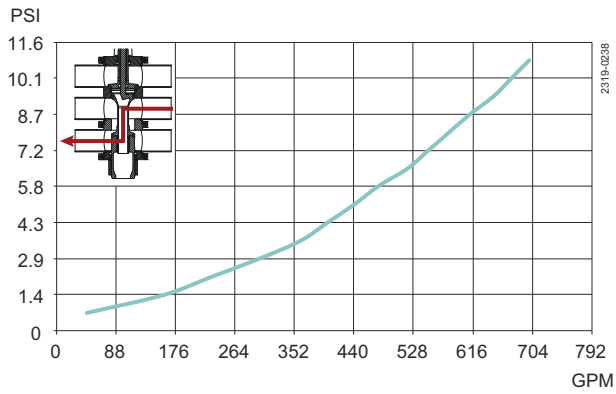
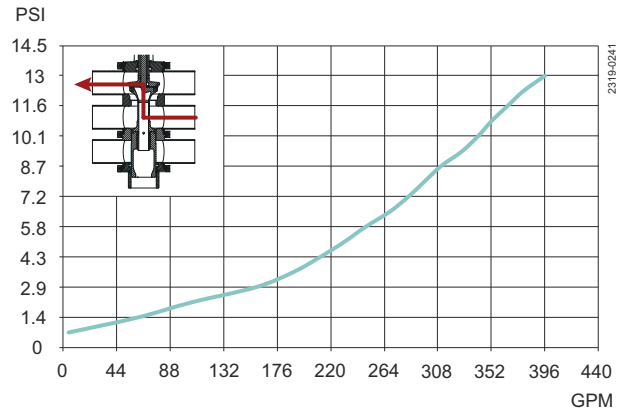
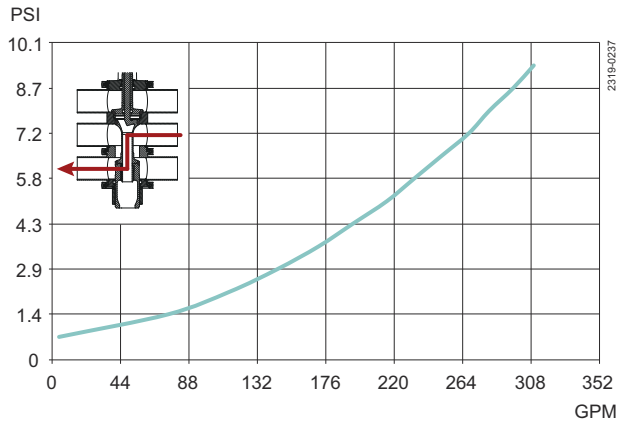

Middle body

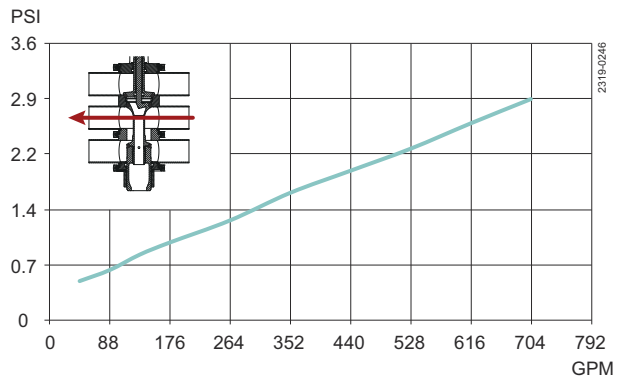
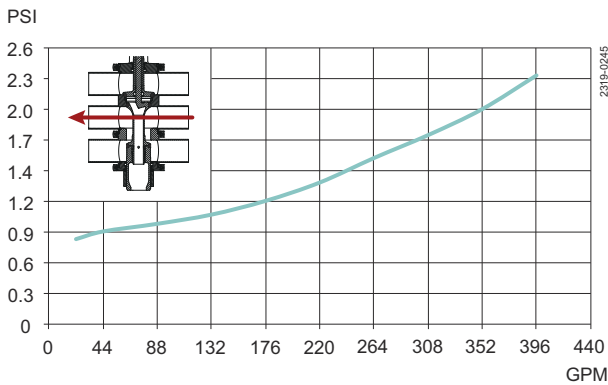
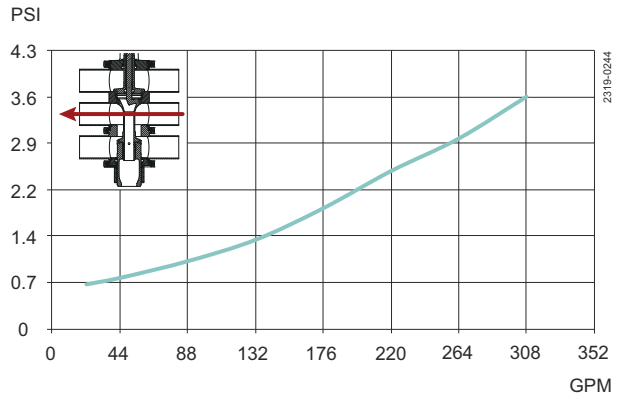
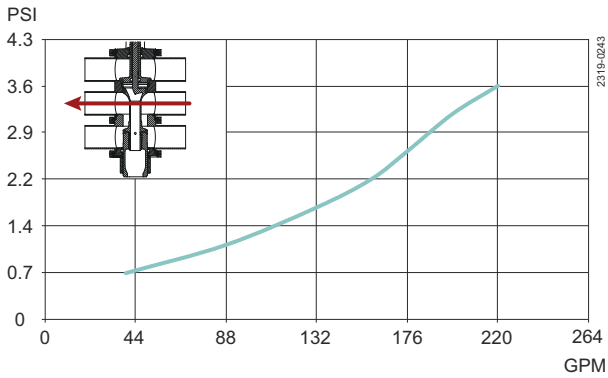

Air and CIP consumption

| Size | OD | OD | OD | OD | OD |
|---|------|------|------|------|------|
| ISO | 1½" | 2" | 2½" | 3" | 4" |
| Kv-value | | | | | |
| Upper Seat-lift [gpm/psi] | 1.7 | 1.7 | 2.9 | 2.9 | 3.6 |
| Lower Seat-lift [gpm/psi] | 1.0 | 1.0 | 2.2 | 2.2 | 2.9 |
| Air consumption | | | | | |
| Upper Seat-lift ¹ [cubic inches] | 12 | 12 | 24 | 24 | 38 |
| Lower Seat-lift ¹ [cubic inches] | 6.7 | 6.7 | 8 | 8 | 13 |
| Main Movement ¹ [cubic inches] | 52 | 52 | 99 | 99 | 170 |
| Cv-value SpiralClean | | | | | |
| Spindle CIP [gpm/psi] | 0.14 | 0.14 | 0.14 | 0.14 | 0.14 |
| External CIP of leakage chamber [gpm/psi] | 0.29 | 0.29 | 0.34 | 0.34 | 0.34 |



Note! Recommended min. pressure for SpiralClean: 29 bar.

¹ [n litre] = volume at atmospheric pressure

Formula to estimate CIP flow during seat lift:

(for liquids with comparable viscosity and density to water):

$$Q = K_v \cdot \sqrt{\Delta p}$$

$$Q = \text{CIP - flow (m}^3/\text{h)}.$$

K_v = K_v value from the above table.

Δp = CIP pressure (bar).

Actuator

| | STD | | | | | STD/STD* |
|---------------------|--|------------------|-------------------|------------------|-------------------|--|
| | Operating pressure for SeatClean, High Clean and Ultra Clean at 6 bar air pressure | | | | | Operating pressure for Basic at 6 bar air pressure |
| Actuator Type | 3 | 4BS ¹ | 4SS ² | 5BS ¹ | 5SS ² | |
| Actuator dimensions | 4.72 x | 6.18 x | 7.32 x | 7.32 x | 7.32 x | |
| øD x L | 9.06 | 9.92 | 11.06 | 11.06 | 14.92 | |
| Tube OD | | | | | | |
| 1½" | STD ³ | OP ⁴ | OP ⁴ | | | 140 |
| 2" | STD ³ | OP ⁴ | OP ⁴ | | | 140 |
| 2½" | OP ⁴ | STD ³ | STD* ⁵ | OP ⁴ | OP ⁴ | 140 |
| 3" | OP ⁴ | STD ³ | STD* ⁵ | OP ⁴ | OP ⁴ | 140 |
| 4" | | OP ⁴ | OP ⁴ | STD ³ | STD* ⁵ | 116 |

¹ BS = Basic spring

² SS = Strong spring

³ STD: Normal size of actuator

⁴ OP: Alternative size of actuator (NB: For choice and performance of optional actuators please contact Alfa Laval or refer to the Anytime Configurator).

⁵ STD*: Normal size actuator if lower plug is UNBALANCED

Dimensions (inch)

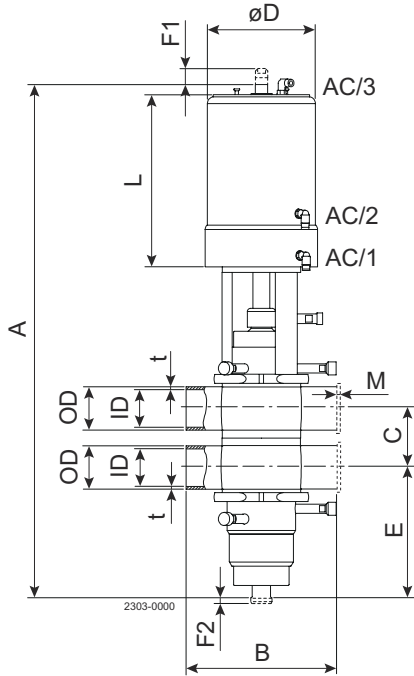

Note for mixed bodies

1. The seat always applies to the smallest valve body.
2. Dimension B is equal with the largest valve body size.

| Size | OD | OD | OD | OD | OD |
|--------------------------------------|-------|-------|-------|-------|-------|
| ISO | 1½" | 2" | 2½" | 3" | 4" |
| A Basic Clean ¹ | 20.88 | 22.66 | 27.54 | 27.54 | 35.03 |
| A Seat Clean ¹ | 20.88 | 22.66 | 26.40 | 26.40 | 31.17 |
| A High Clean/UltraClean ¹ | 24.07 | 25.85 | 29.94 | 29.94 | 36.33 |
| B | 6.70 | 8.67 | 8.67 | 8.67 | 11.82 |
| C ² | 2.40 | 2.91 | 3.40 | 3.90 | 4.87 |
| OD | 1.50 | 2.01 | 2.50 | 3.00 | 4.00 |
| ID | 1.37 | 1.88 | 2.38 | 2.87 | 3.85 |
| t | 0.06 | 0.06 | 0.06 | 0.06 | 0.08 |
| E Basic/Seat Clean | 3.94 | 4.77 | 5.87 | 5.60 | 6.97 |
| E High Clean/Ultra Clean | 5.67 | 6.50 | 7.88 | 7.60 | 9.77 |
| F1 | 1.24 | 1.24 | 1.50 | 1.50 | 2.33 |
| F2 | 0.20 | 0.20 | 0.20 | 0.20 | 0.20 |
| øD Basic | 4.73 | 4.73 | 7.33 | 7.33 | 7.33 |
| øD Seat Clean, | | | | | |
| High Clean and Ultra Clean | 4.73 | 4.73 | 6.19 | 6.19 | 7.33 |
| L Basic | 9.06 | 9.06 | 11.07 | 11.07 | 14.93 |
| L Seat Clean, | | | | | |
| High Clean and Ultra Clean | 9.06 | 9.06 | 9.93 | 9.93 | 11.07 |
| M/Tri-clamp | 0.83 | 0.83 | 0.83 | 0.83 | 0.83 |
| Weight (lb) | | | | | |
| Basic | 30 | 33 | 53 | 53 | 75 |
| Weight (lb) | | | | | |
| SeatClean | 30 | 33 | 53 | 53 | 75 |
| Weight (lb) | | | | | |
| High-/UltraClean | 32 | 35 | 59 | 59 | 84 |

¹ For the A-measure if different upper/lower body sizes, please refer to Anytime configurator or contact Alfa Laval.

² The measure C can always be calculated by the formula $C = \frac{1}{2}ID_{upper} + \frac{1}{2}ID_{lower} + 1.02$ inch.

Dimension for 3-body version

| Group | 3 | 4 | 4 | 5 | 3 | 4 | 4 | 5 |
|--------------------------|-------|-------|-------|-------|-------|-------|-------|-------|
| Size | DN/OD | DN/OD | DN/OD | DN/OD | DN | DN | DN | DN |
| ISO-DIN | 2" | 2.5" | 3" | 4" | 50 | 65 | 80 | 100 |
| A - without Spiral Clean | 24.24 | 28.14 | 28.68 | 34.54 | 24.24 | 28.14 | 29.32 | 34.54 |
| A - with Spiral Clean | 27.41 | 31.68 | 32.22 | 39.69 | 27.41 | 31.68 | 32.86 | 39.7 |
| A - Flushed | 24.06 | 27.82 | 28.59 | 34.36 | 24.24 | 28.14 | 29.32 | 34.54 |
| B | 8.66 | 8.66 | 8.66 | 11.81 | 8.66 | 8.66 | 8.66 | 11.81 |
| **C | 2.91 | 3.4 | 3.89 | 4.87 | 2.99 | 3.62 | 4.21 | 4.96 |
| OD | 2.01 | 2.5 | 3 | 4 | 2.09 | 2.76 | 3.35 | 4.09 |
| ID | 1.88 | 2.37 | 2.87 | 3.84 | 1.97 | 2.6 | 3.19 | 3.94 |
| t | 0.06 | 0.06 | 0.06 | 0.08 | 0.06 | 0.08 | 0.08 | 0.08 |
| E - without Spiral Clean | 3.41 | 4.23 | 4.03 | 5.49 | 3.28 | 3.9 | 4.19 | 5.35 |
| E - with Spiral Clean | 5.13 | 6.22 | 6.02 | 8.29 | 5 | 5.89 | 6.18 | 8.15 |
| E - Flushed | 3.24 | 3.92 | 3.94 | 5.31 | 3.28 | 3.9 | 4.19 | 5.35 |
| F1 | 1.24 | 1.5 | 1.5 | 2.32 | 1.24 | 1.5 | 1.5 | 2.32 |
| F2 | 0.2 | 0.2 | 0.2 | 0.2 | 0.2 | 0.2 | 0.2 | 0.2 |
| øD | 4.72 | 6.18 | 6.18 | 7.32 | 4.72 | 6.18 | 6.18 | 7.32 |
| L | 9.06 | 9.92 | 9.92 | 11.06 | 9.06 | 9.92 | 9.92 | 11.06 |
| M/ISO clamp | 0.83 | 0.83 | 0.83 | 0.83 | | | | |
| M/DIN clamp | | | | | 0.83 | 0.83 | 0.83 | 0.83 |
| M/ISO male | 0.83 | 0.83 | 0.83 | 0.83 | | | | |
| M/DIN male | | | | | 0.91 | 0.98 | 0.98 | 1.18 |
| M/SMS male | 0.79 | 0.94 | 0.94 | 1.38 | | | | |
| M/BS male | 0.87 | 0.87 | 0.87 | 1.06 | | | | |

This document and its contents are subject to copyrights and other intellectual property rights owned by Alfa Laval Corporate AB. No part of this document may be copied, re-produced or transmitted in any form or by any means, or for any purpose, without Alfa Laval Corporate AB's prior express written permission. Information and services provided in this document are made as a benefit and service to the user, and no representations or warranties are made about the accuracy or suitability of this information and these services for any purpose. All rights are reserved.

How to contact Alfa Laval

Up-to-date Alfa Laval contact details for all countries are always available on our website at www.alfalaval.com