

Ampco Pumps Company

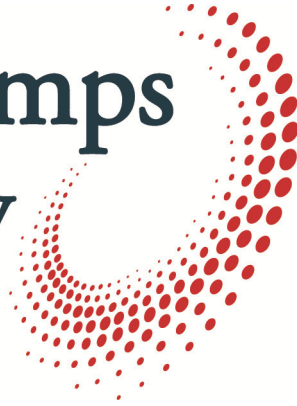

Ampco SP Series

Self-priming Liquid Ring Pump

Installation and Maintenance Manual



Introduction	3
Introduction	3
General Information	3
Shipping Damage or Loss.....	3
Receiving/Safety	3
Pump Receiving	3
Safety	3
Pump Information	5
Instructions	5
Location.....	5
Installation	5
Starting.....	5
Maintenance	6
Troubleshooting.....	11
Ampco Pumps Terms and Conditions	12
Gmbh Terms and Conditions	15
Return Policy	20
Certification Information.....	21

Introduction

To ensure the best results and service, please read and fully understand this manual prior to putting this pump into service. For any questions regarding operation, maintenance, or installation, please contact your local distributor or Ampco Pumps Company:

Ampco Pumps Company

2045 W. Mill Road

Glendale, WI 53209

Phone: (800) 737-8671 or (414) 643-1852

Fax: (414) 643-4452

Email: ampcocs@ampcopumps.com

General Information

Each Ampco “SP” Series pump is fully assembled, lubricated, and tested at the factory and shipped ready for use. Standard maintenance practices are outlined in this manual. For more information, please refer to Maintenance. Following these guidelines will provide long-lasting, trouble-free service when the pump is incorporated in a properly designed system.

Shipping Damage or Loss

Upon receiving equipment that is damaged or if your shipment is lost in transit, immediately file a claim with the carrier. At time of pick-up, the carrier signed the bill of lading, acknowledging that they have received the product from Ampco in good condition.

Pump Receiving

Ampco covers the pump inlet and discharge ports prior to shipping, ensuring that foreign matter does not enter the pump during shipment. If the protective covers are missing upon arrival, remove the pump cover and inspect to ensure it is free from contaminate before turning the shafts. Please make note of the pump serial number; this will assist in the process of ordering replacement parts and/or a warranty claim. For more information regarding shipment damage or warranty, please refer to Terms and Conditions.

Safety

IMPORTANT: Read and understand this manual BEFORE installation, operation or maintenance of the pump. Improper installation, operation, or maintenance may result in severe injury or death. Equipment damage caused by user neglect will invalidate the pump warranty.

There are safety symbols used throughout this manual identifying safety concerns.



WARNING: Hazards or unsafe practices that COULD result in severe personal injury or death, and how to avoid them.

CAUTION: Hazards or unsafe practices that COULD result in minor personal injury or damage to product or property.

INSTRUCTIONS

Your Ampco centrifugal pump in a rugged unit designed to provide years of low cost pumping service. There is a small amount of necessary care required to ensure you of this expected long service. It is recommended that you carefully review the installation and operating sections in this manual.

Every Ampco pump receives a careful running test at the factory to ensure that the head-capacity rating is met in accordance to the Hydraulic Institute Standards and to ensure mechanical soundness. Special instructions and advice for unusual conditions, such as corrosive, abrasive, and other problems are too numerous to be included in this general manual, but will be the subject of specific discussion on orders or inquiries for special applications.

LOCATION

The immediate environment in which the unit is located, while usually of prime importance to the pump, may determine the enclosure needed for the motor. Ampco can supply several different motor enclosures to meet specific requirements.

The SP Series pumps are supplied with totally enclosed motors as standard. They may be installed where dirt, moisture and mild corrosion are present or in outdoor locations. Washdown duty motors, with epoxy paint or paint free stainless steel, are designed for applications where the motor is frequently subject to washdown to maintain a bacteria-free operating environment. Specialty motors may be required for moist, corrosive, or explosive environments. Motor drain plugs (if not equipped with automatic drains) must be physically removed periodically to drain accumulated condensation.

Pump units should be located where daily visual inspection is possible and no surrounding structure interferes with ventilating air over or through the motor.

Submerged suction is the most economical and convenient method of priming a pump when installed in such a position that the top of the casing is below the surface of the liquid to be pumped. The liquid will flow by gravity into the pump and displace the air (through the discharge if possible or a vent when available).

INSTALLATION

Begin with a suction line as direct and as simple as possible. The suction line is usually the most sensitive part of the entire pumping system, being totally dependent on outside forces to provide liquid flow into the center of the impeller.

Locate the pump as close to the supply of liquid as possible, with short and direct suction piping. Use wide radius elbows to help reduce friction loss. Air pockets due to high sections, concentric reducers, valve bonnets, etc. should be eliminated by installing a suction having a continual rise or at the very least a straight horizontal run with an air eliminator near the pump suction entry. To prevent air pockets use eccentric pipe reducers that are mounted in a horizontal position across the top of the pipeline and valves that can be positioned in a plane rather than the normal upright position as an air pocket may exit in the upright valve bonnet.

Above all, remember that until the liquid reaches the leading edges of the rotating impeller vane the pump cannot impart its energy to move the liquid.

If possible, try not to connect an elbow directly to the inlet of the pump. This may cause excessive turbulence and hinder pump performance.

STARTING

The pump must be primed before starting, as the mechanical seal depends on the liquid being pumped for lubrication and cooling. Even a short run to determine direction of rotation without first priming may seriously damage the seal. Even though the SP series are "self-priming" they require fluid inside the pump casing to draw a proper vacuum to initiate the priming.

The correct direction of rotation is counter-clockwise when viewed from the suction end of the pump. It is recommended to turn the pump by hand before starting the first time to ensure the unit is not binding.

MAINTENANCE

Since long-term breakdown cannot be tolerated in most services, maintenance procedures and a contingency plan must be established in advance to minimize any production loss caused by downtime. During building and start-up it is common to use outside personnel. Operating personnel should acquaint themselves with the pump, particularly its running performance. This will aid in establishing a standard for future reference. This manual and other information provided with the pump should be filed for future reference.

All possible performance data should be recorded once the system is functioning properly and stable. Suction and discharge pressure readings, flow rate, seal leakage rate, bearing temperature, noise and vibration levels all provide input to a pump's performance in the system. It is unlikely that all of this data can be measured, but any information gathered can help alert the user of problems with the pump or system.

Operating personnel should know that any changes in the system or the liquid being pumped might have an effect on the pump's performance. It is advisable to also record the fluid temperature, specific gravity, viscosity, liquid concentration, percent of solid concentration, other additives and properties.

Operating personnel should know that any changes in the system or the liquid being pumped might have an effect on the pump's performance. It is advisable to also record the fluid temperature, specific gravity, viscosity, liquid concentration, percent of solid concentration, other additives and properties. A proper maintenance procedure should begin with a file for each pump. All known data relative to the pump, fluid handled and system should be included. Complete records of maintenance and repair costs along with a log of the units operating hours should be kept.

In addition, complete pump identification- size, type, operating speed, manufacturer, serial number, model number, and material of construction should be noted.

Maintenance Procedures

Daily Check – possibly the most important inspection will be the daily observation.

1. Seal leakage rate
2. Pressure reading and flow indication
3. Change in operating sound
4. Change in bearing temperature
5. Check to make sure flow is going through the double seal flush lines (for Double Seal pumps)

Semi-Annual Inspection – typically made at 6-month intervals with results noted in the pumps maintenance file.

1. Check of mechanical seal assembly
2. Check of bearing lubrication

Annual Inspection – includes Semi-Annual inspection plus:

1. Removal of seal for inspection
2. Bearing check
3. Check of axis/running clearance of impeller

Contingency Plan

For inspection findings and breakdowns, a contingency plan should be developed. To begin, an adequate supply of probable replacement parts should be kept on hand.

The minimum recommended spare parts are as follows:

1. Mechanical seal kit (complete with O-ring set)
2. Casing O-ring
3. Impeller key

In addition Ampco recommends

1. Impeller
2. Impeller nut / bolt and washer (SP 240 only)

Where service cannot be interrupted, a complete stand-by pump unit fully assembled (and in a by-pass line) is recommended.

DISMANTLE AND REPLACE PARTS AS FOLLOWS:

Before attempting any service on the pump or motor, disconnect or lock out electrical power to the pump motor. If the pump and motor are to be removed as a unit, note the wiring configuration. Use colored or numbered tape to mark the wire connections of the motor and power source, for reconnection.

These instructions are limited to fluid ends only; see other drawings and literature applicable to motors, pedestals, frames, shafts, etc. if additional repairs are required.

REQUIRED TOOLS

1. Rubber mallet
2. 15/16" socket—for impeller nut
3. 3/8" diameter steel rod—to hold stub shaft
4. One— 3/4" wrench (frame sizes 280 & larger) - adapter bolts
5. Food grade lubricant (for gaskets and O-rings)
6. Allen wrench for shaft collar bolts :
3/16" 180 frame, 1/4" 210-250 frame,
5/16" 280-320 frame, 3/8" 360 frame
7. Impeller puller / pinch bars (may be necessary)
8. Shim (see impeller gap chart for sizes)
9. Food grade anti-seize lubricant

1. Disconnect the pump from both suction and discharge piping.
2. Remove the shaft cover guard at this time by taking off the cover guard bolts.
3. Remove cover by taking off the casing nuts. A rubber mallet may be necessary to loosen the nuts.
4. Remove the impeller nut (bolt) using a 15/16" socket (7/8" for sp240 pump) and holding the stub shaft with a 3/8" rod in the predrilled hole. Ease the impeller off the shaft. Pinch bars between the impeller and cover may be required. Be careful not to mar the pumps surface finish. Remove the impeller.
5. Use a 3/4" wrench to remove all three bolts between the pump volute and the adapter and gently slide the pump volute off the pump shaft.
6. Lay the pump volute down on the casing studs, and remove the stationary seal. The wave springs for the seal should also be removed. In double seal pumps, there is an extra stationary piece and wave spring to remove.
7. Remove the two stationary seal O-rings. This is best done by using a small flat-blade screwdriver.
8. Remove the rotating seal and rotating seal O-ring from the stub shaft.

The Mechanical Seal is the only expendable pump part. It is suggested that the complete mechanical seal, both stationary and rotating members, be replaced whenever dripping or leakage occurs at the shaft, or whenever parts are removed to the point of separating the primary sealing surfaces.

The fluid end is now completely dismantled: Additional procedures are dictated by purpose for which unit was disassembled.

Mechanical Seal Replacement and Reassembly

Please see the table on pages 4 and 5 for proper identification of all pump components.

1. Begin by installing the rotating assembly onto the stub shaft. Lubricate the rotating O-ring with a food grade lubricant (use de-ionized water if oil is not permitted i.e. EPDM) and fit it into the rotating seal. Slide the assembly onto the shaft and line it up with the notches on the shaft.
2. Set the pump volute down on the casing studs. Lubricate the inner stationary seal O-ring and put it in the groove in the seal cavity. For double seal pumps, the outer stationary O-ring fits into the larger groove in the seal cavity.
3. Place the inner (and outer) wave spring into the seal cavity and align it around the pins in the seal cavity. The wave spring should be positioned so that the waves with the notches face downward by the pins.
4. Install the inner stationary seal. The notches in the seal will line up with the pins in the cavity. For a double seal, install the outer rotating seal second.
5. Being careful not to bump the seal on the pump stub shaft, gently slide the volute over the stub shaft and shoulder it against the adapter.
6. Use a 3/4" wrench to alternatively tighten all bolts between the volute and the adapter.
7. Place the impeller key onto the shaft keyway in the pump.
8. Lubricate impeller O-ring and fit into the groove on the back of the impeller

9. Slide the impeller onto the pump shaft over the key. Next, lubricate the impeller nut gasket and install it on the impeller along with threading on the impeller nut. Be sure that the gasket fits into the groove in the impeller nut. For SP 240 pumps lubricate and install both impeller bolt and washer O-rings.
10. Tighten the impeller nut. This should be done with a 15/16" socket (7/8" for SP 240 pumps) while using a 3/8" rod in the stub shaft hole to keep the pump shaft from rotating. Check the freedom of parts by hand rotating the impeller.
11. Install the cover onto the pump volute with a new cover O-ring. It is best to put the O-ring on the cover as it is placed against the volute. Tighten all cover nuts uniformly. Rotate the shaft by hand again to check for rubbing.
12. Re-install the shaft cover guard.
13. For double seal pumps, install the flush lines through the back of the casing. Run flush water at about 1-2 gallons per hour. The maximum pressure for the seal is 5 PSI. Flush water should be throttled before the pump, and there should be about 2-5 feet of vertical tubing after the flush water exits the pump to maintain this.
14. Place the pump back into service and inspect for proper rotation and leaks.

Motor / Pump Shaft Disassembly

Before attempting any service on the pump and motor, disconnect or lock out electrical power to the pump motor. If the pump and motor are to be removed as a unit, note the wiring configuration. Use colored or numbered tape to mark the wire connections of the motor and power source, for reconnection.

1. Begin with pump disassembly as noted previously.
2. Loosen the shaft collar with an Allen wrench (see sizes in the table on page 10) so that the stub shaft can be taken off the motor. A rubber mallet may be used to tap the stub shaft if it will not slide off. Be careful not to drop the shaft collar when the stub shaft comes off the motor.

At this time the motor can be replaced by unbolting the adapter from it and separating the two items.

Motor / Pump Shaft Assembly

If the pump stub shaft is being replaced, it is recommended that a new shaft collar also be installed.

1. Begin by bolting the adapter onto the motor. Please note correct tightness of all fastening components in the table in page 10.
2. Slide the shaft collar onto the stub shaft and slide the two together onto the motor shaft, keeping the motor keyway in line with one of the slots in the stub shaft. If the collar has an identification groove in it, this will rest against the step in the stub shaft.
3. Line up the slot in the collar with the stub shaft slot and motor keyway gap. Do not tighten the shaft collar yet. Since the shaft was disassembled, the impeller clearance in the volute may have changed. The impeller must be positioned to ensure the impeller will not rub and also for proper pump performance. The critical impeller gap is the gap between the volute and the impeller. This will be measured using the spacer provided with the SP series pumps. Please see the table on page 10 within the manual for the correct impeller gaps.
4. Slide the volute over the pump shaft and shoulder it against the adapter.
5. Use a 3/4" wrench to alternatively tighten all bolts between the volute and the adapter.
6. Place the spacer provided with the pump between the casing and the impeller. Install the impeller key, followed by the impeller, impeller nut gasket, and impeller nut (bolt & washer, SP-240 only). Tighten the impeller nut using a socket wrench and the 3/8" rod to hold the shaft to secure the assembly.
7. With a rubber mallet, gently tap the impeller nut (bolt & washer, SP-240 only) to drive the stub shaft towards the motor, while the spacer is between the impeller and volute. This will create the critical impeller gap.
8. When the impeller gap is correct, align the shaft collar slot with the slot in the stub shaft and the motor shaft keyway, and tighten the shaft collar with an Allen wrench, (see sizes in table on page 10) to secure the shaft position.
9. Remove the impeller nut (bolt & washer, SP-240 only), gasket, and impeller from the shaft, and the spacer. Now finish reassembling the pump.

Mechanical Seal Assembly for SP Series Pumps (items 3, 4, and 7 for double seal pumps only)

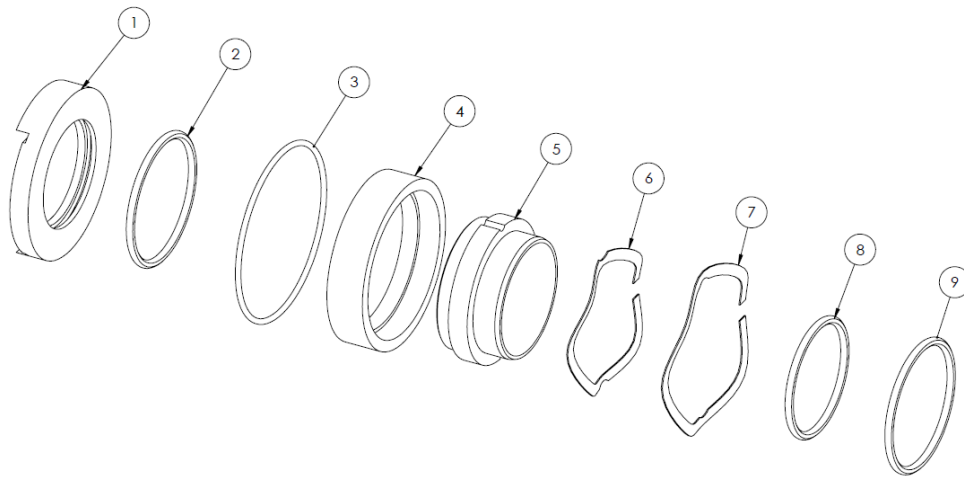

Item	Component Name
1	Rotating Seal
2	Rotating Seal O-ring
3	Double Seal O-Ring
4	Double Seal
5	Stationary Seal
6	Single Seal Wave Spring
7	Double Seal Wave Spring
8	Single Seal O-Ring
9	Impeller O-Ring

SP Series Pump Component Breakdown

For all SP Series Pumps Except SP-240

Item No.	Qty.	Component Name
1	1	Adapter
2	1	Stubshaft Collar
3	1	Stubshaft
4	1	Casing
4.1	3	Casing Bolt
4.1	3	Casing Washer
5	1	Stationary Seal
6	1	Double Stationary Seal
7	1	Rotating Seal
8	1	Cover
9	1	Cover Gasket
10	1	Impeller
10.1	1	Impeller Key
11	1	Impeller Nut
11.1	1	Impeller Bolt O-Ring
12*	3-5	Casing Wing Nut
13	1	Shaft Guard (not shown)
13.1	2	Shaft Guard Screw
14	1	Motor
14.1	4	Motor Bolt
14.2	4	Motor Washer

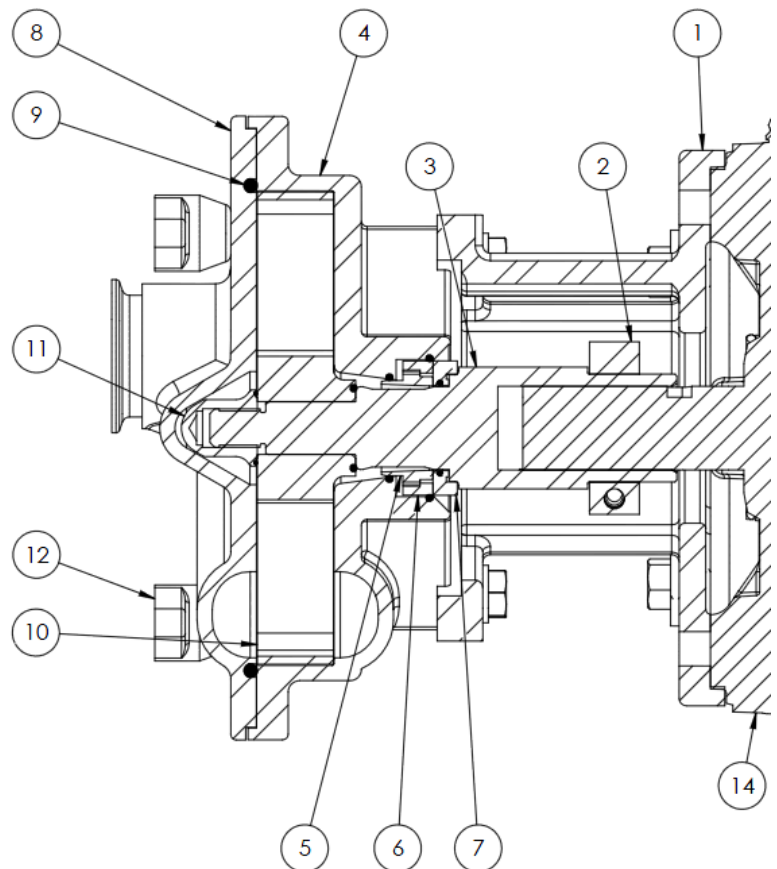

* Wing nut quantity varies with pump model

SP Series Pump Component Breakdown

SP-240 Pump Only

Item No.	Qty.	Component Name
1	1	Adapter
2	1	Stubshaft Collar
3	1	Stubshaft
4	1	Casing
4.1	3	Casing Bolt
4.1	3	Casing Washer
5	1	Stationary Seal
6	1	Double Stationary Seal
7	1	Rotating Seal
8	1	Cover
9	1	Cover Gasket
10	1	Impeller
10.1	1	Impeller Key
11	1	Impeller Washer
11.1	1	Impeller Washer O-Ring
12	1	Impeller Bolt
12.1	1	Impeller Bolt O-Ring
13	5	Casing Wing Nut
14	1	Shaft Guard
14.1	2	Shaft Guard Screw
15	1	Motor
15.1	4	Motor Bolt
15.2	4	Motor Washer

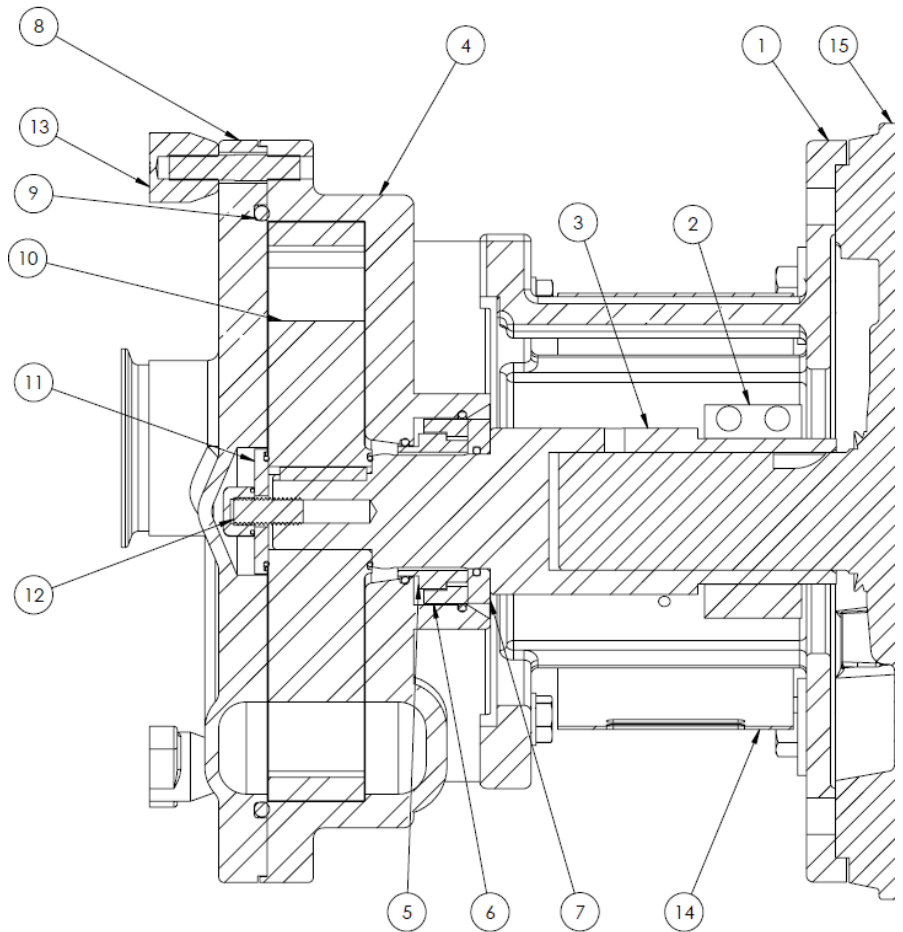

NOTE:

Please be sure to always include pump type, size, and serial number with any reference to above numbers and names.

Proper Impeller Clearances for SP Series Pumps

Pump Series	Impeller to Volute
SP 200	0.008"
SP 240	0.020"

Proper Torque for Bolts on SP Series Pumps

Component Name	Torque	Pumps Included
Motor Bolts	50	All SP Pumps
Casing Bolts	50	All SP Pumps
Casing Wing Nuts	50	280+ Frame
Impeller Nut	40	210-250 Frame
Impeller Bolt	40	SP 240 Only
Shaft Collar Bolts	15 30 40 40	180 Frame 210-250 Frame 280-320 Frame 360 Frame

TROUBLE SHOOTING

It is to the user's advantage to be familiar with a systematic procedure to determine reasons and causes for unsatisfactory pump operation. The following list of troubles and causes is intended to assist users in determining the cause of any pumping trouble. Faulty installations can then be corrected and a clear description given to the manufacturer if assistance is required. Human judgement should not be relied upon to measure operating conditions. Use proper instruments to measure values of pressure, suction lift, speeds, temperature rise of motors, etc. When motor speeds are incorrect, check connections and measure voltage at motor terminals.

1. **No liquid delivered**

- a. Pump and suction line not completely primed
- b. Speed too low
- c. Required discharge too high
- d. Suction lift too high
- e. Impeller, piping, or fittings completely plugged up
- f. Wrong direction of rotation

2. **Not sufficient capacity**

- a. Air leaks in suction pipe or shaft seal
- b. Speed too low
- c. Required discharge head too high
- d. Suction lift too high or insufficient NPSH available
- e. Impeller, piping, or fittings partially plugged
- f. Insufficient positive suction head for hot water or other volatile liquids
- g. Liquid viscosity too high
- h. Mechanical problems – impeller damaged, shaft seal defective
- i. Wrong direction of rotation
- j. Suction pipe entrance too close to surface of liquid
- k. Air pockets in pipe high points

3. **Insufficient pressure**

- a. Speed too low
- b. Mechanical problems – impeller damaged, shaft seal defective
- c. Small impeller diameter
- d. Air or gas in liquid
- e. Wrong direction of rotation
- f. Air pockets in pipe high points

4. **Pump operates for a while, then quits**

- a. Leaky suction line
- b. Air leaking in through shaft seal
- c. Suction lift too high or insufficient NPSH available
- d. Air or gas in liquid
- e. Suction piping and fittings not completely freed of air during priming
- f. Air pockets in pipe high points

5. **Pump takes too much power**

- a. Speed too high
- b. Pumping too little water (too much pressure) because required head is higher than anticipated
- c. Viscosity and/or specific gravity is higher than specified
- d. Mechanical problems – binding inside seal from distortion due to piping strains, shaft bent, impeller rubbing casing
- e. Wrong direction of rotation
- f. Wrong motor voltage or wiring

AMPCO PUMPS

Made of SELECTED corrosion-resistant alloys

U.S. TERMS AND CONDITIONS OF SALE

1. ENTIRE AGREEMENT. This document contains all of the terms and conditions of the agreement ("the agreement") between Ampco Pumps Company, Inc. ("Seller") and the purchaser ("Purchaser") of the Products ("Products") to be sold to Purchaser, to the exclusion of any other statements and agreements, and to the exclusion of any terms and conditions incorporated in Purchaser's order or other documents of Purchaser. Seller's acceptance of Purchaser's order is expressly conditioned on Purchaser's acceptance of the terms and conditions contained herein, and Purchaser, upon placing an order, is presumed to have accepted all the terms and conditions without modification. No alteration, waiver, modification of or addition to the terms and conditions herein shall be binding on Seller unless set forth in writing and specifically agreed to by an officer of Seller. No course of dealing, usage of trade or course of performance will be relevant to supplement or explain any terms used in the agreement. All offers to purchase, quotations and contracts of sale are subject to final acceptance by Seller at its home office at Milwaukee, Wisconsin.

2. PRICES. Prices for Products manufactured by Seller pursuant to written accepted orders will remain firm for thirty (30) days from the date of any subsequent price change.

3. TERMS OF PAYMENT. Standard terms are 1/2% 10 days, 30 days net, from date of invoice unless otherwise stated. If, in the judgment of Seller, the financial condition of Purchaser at any time does not justify continuance of production or shipment on the terms of payment specified, Seller may require full or partial payment in advance. In cases of delays in payment, Seller reserves the right to charge interest on delinquent balances at the rate of 1 1/2% per month.

4. DELIVERY. Except as otherwise provided expressly stated in the agreement, Products are sold F.O.B. Milwaukee. Seller will use reasonable commercial efforts to fill orders within the time stated, but the stated delivery date is approximate only, and Seller reserves the right to readjust shipment schedules without liability. Acceptance by Purchaser of the Products waives any claim for loss or damage resulting from a delay, regardless of the cause of the delay. Except as otherwise provided herein, Seller will not be responsible for freight, transportation, insurance, shipping, storage, handling, demurrage or similar charges. Claims by Purchaser for shortages in the Products must be made to Seller in writing within ten (10) days after date of receipt of the Products. No such shortage shall entitle Purchaser to withhold payment for Products which were received by Purchaser. Each such claim shall set forth in detail the basis and amount of such claim.

5. TAXES AND FEES. Seller shall pay all present and future sales, excise, privilege, use or other taxes, customs duties, and all other fees or other costs, imposed by any federal, state, foreign, or local authorities arising from the sale, purchase, transportation, delivery, storage, use or consumption of the Products or will, if applicable, provide Seller with an appropriate exemption certificate. Seller shall be under no obligation to contest the validity of any such taxes or to prosecute any claims for refunds or returns.

6. INSTALLATION. The Products shall be installed by and at the expense of Purchaser.

7. LOSS, DAMAGE OR DELAY. Seller will not be liable for loss, damage or delay resulting from causes beyond its reasonable control, including, without limitation, strikes or labor difficulties, lockouts, acts or omissions of any governmental authority or Seller, insurrection or riot, war, fires, floods, Acts of God, breakdown of essential machinery, accidents, embargoes, cargo or material shortages, delays in transportation, lack of production capacity or inability to obtain labor, materials or parts from usual sources. In the event of any such delay, performance will be postponed by such length of time as may be reasonably necessary to compensate for the delay. In the event performance by Seller under the agreement cannot be accomplished by Seller due to any of the foregoing causes within a reasonable period of time, Seller may, at its option, terminate the agreement without liability.

8. RETURNS. No Products or parts may be returned by Purchaser without the prior written consent of Seller.

9. WARRANTY. Seller warrants that the Products manufactured by Seller will be free from defects, material and workmanship under normal use and service for a period of one (1) year from date of shipment. In addition, the specified rating of each pump is warranted; however, the characteristic shape of the performance curves may vary from the published standards, and the capacity, head and efficiency guarantees are based on actual shop tests using clear cold water, and therefore the rating is specified in equivalent units of clear cold water. The sole obligation of Seller and the exclusive remedy of Purchaser for breach of this warranty shall be the repair (at Seller's facility) or replacement by Seller (F.O.B. Milwaukee, Wisconsin), at Seller's option, of any parts found to be defective, without charge and shall be conditioned upon Seller receiving written notice of any alleged breach of this warranty within a reasonable time after discovery of the defects, but in no event later than the end of the warranty period. The parts alleged to be defective shall be returned to Seller upon its request, freight prepaid. This warranty does not cover ordinary wear and tear, abuse, misuse, overloading, alteration or Products or parts which have not been installed, operated or maintained in accordance with Seller's written instructions. Seller shall not be liable for any expenses for repairs, additions or modifications to the Products outside of Seller's factory without its prior written consent, and any such repairs without such consent shall void this warranty. THIS WARRANTY IS EXCLUSIVE AND IS IN LIEU OF ALL OTHER EXPRESS AND IMPLIED WARRANTIES WHATSOEVER, INCLUDING BUT NOT LIMITED TO IMPLIED WARRANTIES OF MERCHANTABILITY AND FITNESS FOR A PARTICULAR PURPOSE. Seller may from time to time provide its facilities, personnel and experience to assist customers in the selection of materials, design, installation and operation of Products for maximum resistance to corrosion and abrasion with due consideration to the economy of the installation. This service is provided in an advisory capacity only and the final selection and operation of the Products and ancillary equipment shall be the sole responsibility of Purchaser or any user thereof. Accessories and parts manufactured by third parties are warranted only to the extent of such third party's warranty. IN NO EVENT SHALL SELLER BE LIABLE UNDER ANY CIRCUMSTANCES FOR ANY INCIDENTAL, CONSEQUENTIAL OR SPECIAL DAMAGES (INCLUDING, WITHOUT LIMITATION, ANY LOST PROFITS OR LABOR COSTS) ARISING FROM THE BREACH OF THIS WARRANTY OR OTHERWISE ARISING FROM OR RELATING TO THE PRODUCTS OR THEIR SALE, USE OR INSTALLATION.

10. CHANGES. Changes in any work to be performed hereunder may be made only upon Purchaser's written instructions and acceptance by Seller in its discretion. Any change in drawings, materials or design of the Products, or to tools, fixtures or other items used to produce the Products, which affects Seller's cost to produce the Products will entitle Seller to adjust the price to take into account any additional costs. If work has been started, Seller shall be properly reimbursed for work already performed; if Products already produced are not accepted by Purchaser, Seller has the right to adjust the price to take into account any additional costs caused by an increase or decrease in quantities or in the time required for performance under the agreement.

11. TERMINATION. After Seller has commenced work, ordered any materials or made any other commitments pursuant to the agreement, it may be terminated only with the prior written agreement of Seller providing for equitable cancellation charges. Such charges shall reimburse Seller for any completed items at the contract price, and for any work-in-process items at the contract price less the cost to complete. Termination on any other basis must be specifically agreed on in writing in advance between Purchaser and Seller.

12. DEFERRED DELIVERIES. Orders or deliveries will be deferred only upon the prior written agreement of Seller in its discretion, and then only upon the following conditions:

(a) The deferral period may not exceed sixty (60) days. At the end of the deferral period, if no release is provided by Purchaser, Seller reserves the right to render an invoice for and ship the completed portion of the order to the destination specified in Purchaser's order, or to store such material at Purchaser's expense at Seller's standard storage charges then in effect.

(b) For the portion of the order that is not completed, if no release is provided by Purchaser at the expiration of the deferral period, Seller reserves the right to render an invoice for any completed items at the contract price, and for any work-in-process items at the contract price less the cost to complete.

(c) Purchaser shall bear the risk of loss or damage to materials held at Purchaser's request.

13. LIMITATION OF LIABILITY. IN NO EVENT SHALL SELLER BE LIABLE UNDER ANY CIRCUMSTANCES: (a) FOR ANY INCIDENTAL, CONSEQUENTIAL OR SPECIAL DAMAGES (INCLUDING, WITHOUT LIMITATION, ANY LOST PROFITS OR LABOR COSTS) ARISING FROM OR RELATING TO THE PRODUCTS OR THEIR SALE, USE OR INSTALLATION; (b) FOR DAMAGES TO PROPERTY (OTHER THAN THE PRODUCTS PURCHASED FROM SELLER); (c) FROM ANY BREACH OF ITS WARRANTY OR ANY OTHER OBLIGATIONS TO BUYER; OR (d) FOR ANY OTHER CAUSE WHATSOEVER, WHETHER BASED ON WARRANTY (EXPRESSED OR IMPLIED) OR OTHERWISE BASED ON CONTRACT, OR ON TORT OR OTHER THEORY OF LIABILITY, AND REGARDLESS OF ANY ADVICE OR REPRESENTATIONS (WHETHER OR NOT IN WRITING) THAT MAY HAVE BEEN RENDERED BY SELLER CONCERNING THE DESIGN, MANUFACTURE, SALE, USE OR INSTALLATION OF THE PRODUCTS.

14. INFRINGEMENT. Seller at its expense will defend and hold Purchaser harmless from and against all damages, costs and expenses arising from any valid claim of infringement by a third party with respect to any patent or other intellectual property rights (collectively, the "Intellectual Property Rights") caused by Products originally manufactured by Seller, provided Purchaser (a) has not modified such Products, (b) gives Seller immediate notice in writing of any claim or commencement or threat of suit, and (c) permits Seller to defend or settle the same, and gives all immediate information, assistance and authority to enable Seller to do so. In the event any such originally manufactured Products are held to infringe an Intellectual Property Right and if Purchaser's use thereof is enjoined, Seller will, at its expense and option: (1) obtain for Purchaser the right to continue using the Products, (2) supply non-infringing Products, (3) modify the Products so that they become non-infringing, or (4) refund the then market value of such Products. In no event shall Seller's liability exceed the sale price of the infringing Products. THE FOREGOING REPRESENTS SELLER'S ENTIRE AND EXCLUSIVE OBLIGATION WITH RESPECT TO ANY CHARGE OF INFRINGEMENT OF ANY INTELLECTUAL PROPERTY RIGHT AND IS IN LIEU OF ANY STATUTORY WARRANTY RELATING TO INFRINGEMENT. Notwithstanding the foregoing, Seller shall have no liability as to any Products or parts thereof that are manufactured or modified by Purchaser or a third party, or that are manufactured or modified by Seller in accordance with Purchaser's specifications. Purchaser will defend and hold Seller harmless from and against all damages, costs and expenses whatsoever arising from any claim for infringement of any Intellectual Property Rights relating to Products that have been manufactured or modified by Seller according to specifications provided by Purchaser.

15. CERTAIN LAWS. Seller will comply with the applicable requirements of the Fair Labor Standards Act of 1938, as amended, Executive Order 11246, and THE rules, regulations and orders of the Secretary of Labor relating thereto.

16. PERIOD FOR ACCEPTING QUOTATIONS. Unless accepted without modification within thirty (30) days of issuance, or prior to withdrawal by Seller if earlier, all quotations automatically expire at the end of such thirty (30) day period

17. PROVISIONS FOR INTERNATIONAL TRANSACTIONS. The following provisions shall apply if the Products are to be shipped to Purchaser at a location outside the United States, and apply regardless of other provisions set forth in these Terms and Conditions:

(a) The 1980 United Nations Convention on Contracts for the International Sale of Products shall not apply.

(b) Except as otherwise provided expressly stated in the agreement, terms of delivery are Ex-Works (within the meaning of INCOTERMS 2000) and all customs fees, import duties, cargo insurance, taxes and other charges imposed on or relating to the purchase or sale of the Products shall be paid by Purchaser in addition to the stated price.

(c) Except as otherwise provided expressly stated elsewhere in the agreement, payment shall be made by issuance to Seller of an irrevocable letter of credit which (i) is issued and confirmed by a U.S. bank acceptable to Seller, (ii) is governed by the Uniform Customs and Practice for Documentary Credits (UCP 600) and otherwise acceptable in form and substance to Seller, and (iii) provides for payment to Seller of the purchase price in U.S. dollars upon presentation by Seller of Seller's certification and/or such other documents as shall be required by the letter of credit. All banking and other charges for such letter of credit shall be for the account of Purchaser.

(d) Prices include Seller's standard commercial export packaging which may vary depending on whether shipment is made by air, land or sea. Except as otherwise provided expressly stated in the agreement, Purchaser will bear any additional expenses required to satisfy Purchaser's packaging requirements. Packages will be marked in accordance with Purchaser's instructions, if any. Seller shall furnish packing lists and such other information as may be necessary to enable Purchaser's agent to prepare documents required for export shipment.

(e) All shipments hereunder are subject to compliance with the U.S. Export Administration Act, as amended, regulations thereunder and all other U.S. laws and regulations concerning exports. Purchaser shall comply with all such laws and regulations concerning the use, disposition, re-export and sale of the Products provided hereunder.

18. GENERAL. No modification or waiver of the agreement or any of its provisions is valid unless expressly agreed to by Seller in writing, and no waiver by Seller of any default under the agreement is a waiver of any other or subsequent default. The unenforceability or invalidity of one or more of the provisions of the agreement will not affect the enforceability or validity of any other provision of the agreement. Purchaser may not assign any of its rights, duties or obligations under the agreement without Seller's prior written consent and any attempted assignment without such consent, even if by operation of law, will be void. The agreement is governed by and shall be construed in accordance with the laws of the State of Wisconsin, including the Uniform Commercial Code as enacted by such state, without giving effect to its conflict of laws principles.

GmbH General Terms and Conditions of Service, Sale and Delivery

- I. Content of the contract, scope of application, offer
1. All deliveries and services of Ampco Pumps GmbH are made exclusively on the basis of the General Terms and Conditions of Performance, Sale and Delivery of Ampco Pumps GmbH described here. Deviating terms and conditions of the Client shall not be recognised by Ampco Pumps GmbH unless Ampco Pumps GmbH has expressly agreed to their validity in writing. These General Terms and Conditions of Performance, Sale and Delivery of Ampco Pumps GmbH shall also apply if Ampco Pumps GmbH executes the delivery to the Client without reservation in knowledge of the Client's terms and conditions that conflict with or deviate from these Terms and Conditions.
2. These terms and conditions apply to all services of Ampco Pumps GmbH, regardless of the legal nature of the contract on which the service is based. They therefore apply to purchase contracts as well as to contracts for work, contracts for the supply of work and for combined contracts.
3. Individual agreements on the rights and obligations of the contracting parties take precedence over these Terms.
4. All agreements made between Ampco Pumps GmbH and the Client for the purpose of executing the contract must be recorded in writing.
5. These terms and conditions only apply to entrepreneurs, legal entities under public law and special funds under public law (in each case within the meaning of § 310 BGB).
6. These terms and conditions shall also apply to all future transactions between Ampco Pumps GmbH and the Client.
7. If the order qualifies as an offer according to § 145 BGB, Ampco Pumps GmbH can accept it within four weeks of receipt.
- II. Documents, preparatory work, trade secrets
1. Ampco Pumps GmbH reserves all rights, in particular the right of ownership and copyright, to cost estimates, calculations, plans, illustrations, design work, preliminary work, drawings and other documents. They may only be made available to third parties with the written consent of Ampco Pumps GmbH. Ampco Pumps GmbH may only make documents designated as confidential by the Client accessible to third parties with the Client's written consent. Documents transmitted by Ampco Pumps GmbH may only be used for the preparation of the conclusion of the contract and thereafter only for the execution of the contract. Any further use is prohibited.
2. The Client may not disclose to third parties trade secrets of Ampco Pumps GmbH and Ampco Pumps GmbH (within the meaning of Section 15 of the German Stock Corporation Act) of affiliated companies that have become known to him. Ampco Pumps GmbH may not disclose to third parties trade secrets of the client and its affiliated companies (within the meaning of § 15 of the German Stock Corporation Act) that have become known to Ampco Pumps GmbH.
3. Both Ampco Pumps GmbH and the Client are obliged to ensure in an appropriate manner that their bodies and employees also comply with the obligations listed above.
- III. Delivery time, force majeure, delay, acceptance
1. The delivery period begins with the dispatch of the order confirmation and clarification of all technical questions, but not before the production of the plans, documents, permits, approvals, permits to be procured by the customer and before receipt of an agreed down payment.
2. The performance owed by Ampco Pumps GmbH shall be deemed to have been performed in good time if the subject matter of the contract has been properly dispatched by the expiry of the delivery period or if the Client has been notified of the readiness for dispatch.
3. Disruptions in performance caused by force majeure do not give rise to any claims (in particular no claims for contractual penalties or damages) against Ampco Pumps GmbH. Force majeure is defined as any unforeseeable event or such events which, even if foreseeable, are beyond the control of Ampco Pumps GmbH and the effects of which cannot be prevented by reasonable efforts on the part of Ampco Pumps GmbH. These include, but are not limited to, delayed performance by subcontractors/suppliers, war (declared or not), war-like condition, riot, revolution, rebellion, military or civil coup, insurrection, riot, riot, blockade, embargo, government order, sabotage, strikes, slow strikes, lockouts, epidemics, fire, floods, storm surges, typhoons or other severe weather, general shortage of materials, shipwreck, lack of port and unloading capacity, transport-related Delays, unavailability of required vessel space, proper change/replacement of forwarder and/or carrier and/or shipowner and/or other commercial transport companies, transport accidents, earthquakes, radioactive accidents, physical or artificial obstacles of any kind on the construction site/production site.
4. In all cases of hindrances for which Ampco Pumps GmbH is not responsible, regardless of the kind, Ampco Pumps GmbH is entitled to demand an appropriate extension of the delivery periods and additional payments from the customer to compensate for additional services and/or costs.
5. If dispatch is delayed at the request of the Client, the Client shall reimburse the costs actually incurred by the storage of the object of the contract. In the event of storage in a company of Ampco Pumps GmbH, the latter is entitled to demand a flat-rate minimum amount of 0.5% of the agreed price for each month as compensation for the additional costs. The proof of higher (by Ampco Pumps GmbH) or lower (by the client) costs is not excluded by this regulation.
6. Number 5 shall also apply to any other case of default of acceptance by the contracting authority. If the Client is in default of acceptance or violates other obligations to cooperate, the risk of an accidental loss or accidental deterioration of the subject matter of the contract shall also pass to the Client at the time when the latter is in default of acceptance.
7. Further rights of Ampco Pumps GmbH are not excluded by this agreement.
8. Compliance with the delivery deadline presupposes the timely and proper fulfilment of the Client's contractual obligations.
9. Partial deliveries by Ampco Pumps GmbH can only be rejected if they cannot be reasonably expected of the customer.
10. Insofar as acceptance is to take place, the subject matter of the contract shall be deemed to have been accepted if:
 - 10.1. the delivery and, if Ampco Pumps GmbH is also responsible for the installation, the installation has been completed,
 - 10.2. Ampco Pumps GmbH has informed the Client of this with reference to the deemed acceptance pursuant to this number 10 and has requested the Client to accept,
 - 10.3. two weeks have passed since the delivery or installation or the Client has started using the purchased item (e.g. has put the delivered system into operation) and in this case
 - one week has passed since delivery or installation, and
 - 10.4. the Client has failed to accept the goods within this period for a reason other than a defect notified to Ampco Pumps GmbH that makes the use of the goods impossible or significantly impairs.
- IV. Price, transport packaging, payment, price adjustment
1. The agreed prices are ex-works. The shipping costs, including the costs of packaging, loading, stowage and unloading, shall be borne by the Client. In addition to the prices, the VAT in force at the time of delivery is added.
2. Insofar as Ampco Pumps GmbH is obliged under the Packaging Ordinance to take back the packaging used for transport, the Client shall bear the costs for the return transport of the packaging used and the reasonable costs of its recycling. If the returned packaging cannot be reused, the Client shall bear the costs incurred by Ampco Pumps GmbH for its material recycling. In addition, the Client may have to pay the customs duties, customs clearance costs, taxes and duties incurred as a result of the return of the transport packaging.
3. Transport containers are not the subject of the contract and are not considered packaging. They remain the property of Ampco Pumps GmbH. They are to be imported, re-exported and returned to Ampco Pumps GmbH by the Client at the Client's expense (transport costs, customs duties, customs clearance costs, taxes and duties) and risk.
4. Tools, surplus material, welding gas cylinders and other aids are not the subject of the contract. They remain the property of Ampco Pumps GmbH. They are to be imported, re-exported and returned to Ampco Pumps GmbH by the Client at the Client's expense (transport costs, customs duties, customs clearance costs, taxes and duties) and risk.
5. The agreed price is to be credited by the Client at his own risk and expense to one of the bank accounts specified by Ampco Pumps GmbH, without any deduction.
6. Ampco Pumps GmbH is entitled to interest on due dates and arrears in accordance with the statutory provisions. This does not affect the possibility of asserting further damages and rights of Ampco Pumps GmbH.
7. The Client shall only be entitled to rights of set-off and retention if his counterclaims have been legally established, are undisputed or recognised by Ampco Pumps GmbH and their assertion has been notified to Ampco Pumps GmbH at least one month in advance.
8. If, after the conclusion of the contract, Ampco Pumps GmbH becomes aware of circumstances that give rise to doubts about the creditworthiness of the client, Ampco Pumps GmbH may, at its discretion, demand advance payment or suitable security.

9. Ampco Pumps GmbH is entitled to increase the agreed price appropriately if cost increases occur after the conclusion of the contract, in particular due to collective bargaining agreements, material price increases or the increase in transport and packaging costs. Ampco Pumps GmbH will provide proof of this to the Client upon request.
 10. Ampco Pumps GmbH is entitled to increase the agreed price appropriately if, after the conclusion of the contract, the Client wishes to make changes to the subject matter of the contract and these result in additional expenses. Ampco Pumps GmbH will provide the Client with proof of the additional expenditure upon request.
- V. Transfer of risk, transport damage, insurance
1. The risk of accidental loss and accidental deterioration of the subject matter of the contract shall pass to the Client upon handing over the object of the contract to the first carrier.
This also applies if partial deliveries are made or if Ampco Pumps GmbH has assumed further costs, e.g. the shipping costs, or other services, e.g. transport, installation or assembly of the contractual object itself.
 2. If the subject matter of the contract or parts thereof are ready for dispatch and the dispatch or handover is delayed for reasons caused by the Client, the risk of accidental loss and accidental deterioration shall pass to the Client from the day of readiness for dispatch.
 3. If Ampco Pumps GmbH arranges for the transport of the object of the contract and if transport damage or a transport-related material defect occurs on it after it has been handed over to the carrier, Ampco Pumps GmbH shall assign any resulting claims against the transport insurance(s) and the carriers to the customer at the request of the customer – to the exclusion of liability for the existence of these claims, Step by step against payment of the total price agreed for the subject matter of the contract and all costs owed. Further claims against Ampco Pumps GmbH due to transport damage or transport-related material defects are excluded. This also applies if the subject matter of the contract includes assembly services or the construction of a turnkey plant.
 4. Limitation periods under transport law and maritime law, limitation periods, exclusions of liability and limitations of liability in favour of the (natural and legal) persons entrusted with the transport/loading/unloading/storage of the subject matter of the contract in the relationship between them and Ampco Pumps GmbH, shall apply equally to corresponding circumstances in the contractual relationship between the client/Ampco Pumps GmbH in favour of Ampco Pumps GmbH.
 5. The Client undertakes to inspect the subject matter of the contract for damage immediately upon unloading at the port of destination and, in the event of the existence or suspicion of damage, to acknowledge receipt only with reservations and to notify Ampco Pumps GmbH of the damage immediately. In the event of non-compliance with the aforementioned obligations, the obligation to pay the transport insurance(s) does not apply. If the obligation to pay the transport insurance(s) ceases to apply for the aforementioned reason, the liability of Ampco Pumps GmbH for such damages covered by the exclusion of liability of the transport insurance(s) also ceases to apply.
- VI. Retention of title and securities
1. Ampco Pumps GmbH retains ownership of the subject matter of the contract until the irrevocable, unconditional receipt of all payments owed by the Client. Until this date, the Client shall not be entitled to encumber or resell the subject matter of the contract with a security interest (e.g. security property, lien, mortgage, land charge, etc.). In the event that the law applicable at the place of installation (lex rei sitae) does not know the means of security "retention of title", the means of security that comes closest to a "retention of title" according to the law applicable at the place of installation or the means of security that represents the typical means of security (e.g. "lien" or "security interest, attached and perfected") according to this law is agreed instead. The Client is obliged to cooperate (in particular to make declarations of intent) that are necessary under the law applicable at the installation site for the agreement and establishment of a fully effective retention of title or a fully effective other means of security.
 2. In the event of seizures, seizures or other measures taken by third parties in relation to the subject matter of the contract, the Client must point out the ownership of Ampco Pumps GmbH and notify Ampco Pumps GmbH immediately in writing – handing over the documents necessary for an intervention – so that Ampco Pumps GmbH can enforce its property rights.
 3. As long as Ampco Pumps GmbH has rights of the kind referred to in number 1 to the subject matter of the contract, Ampco Pumps GmbH shall be entitled to take back the delivered subject matter of the contract after a reasonable period of time has been set in the event of breaches of duty by the Client, in particular in the event of endangerment of Ampco Pumps GmbH's property in the subject matter of the contract, in the event of improper treatment of the delivered object of the contract by the Client or in the event of default of payment by the Client. The transport costs incurred for the return shall be borne by the Client. If Ampco Pumps GmbH withdraws the subject matter of the contract, this constitutes a withdrawal from the contract. If the Client does not comply with the reclaim, personnel of Ampco Pumps GmbH shall hereby be entitled to enter the Client's installation site (or construction site/production facility) in the required number, to dismantle the delivered object of the contract and to take it with them; all costs incurred for this purpose shall be borne by the Client. The seizure of the subject matter of the contract by Ampco Pumps GmbH always constitutes a withdrawal from the contract.
 4. Ampco Pumps GmbH is entitled to recycle the object of the contract after it has been taken back, and the proceeds of the sale are to be offset against the liabilities of the client – less reasonable exploitation costs.
 5. The Client must treat the subject matter of the contract with care during the ownership and insure it at its own expense against fire, water and theft damage sufficiently at its replacement value. If maintenance and inspection work becomes necessary, the Client must carry it out in good time at its own expense.
 6. The processing or transformation of the subject matter of the contract by the customer is always carried out for Ampco Pumps GmbH. If the subject matter of the contract is processed with other items that do not belong to Ampco Pumps GmbH, Ampco Pumps GmbH acquires co-ownership of the new item in the ratio of the value of the object of the contract (invoice amount) to the other processed items at the time of processing. Incidentally, the same applies to the object resulting from processing as to the subject matter of the contract delivered under reservation.
 7. If the subject matter of the contract is inseparably connected or mixed with other objects not belonging to Ampco Pumps GmbH, Ampco Pumps GmbH acquires ownership of the new item in proportion to the value of the object of the contract (invoice amount) to the other combined or mixed items at the time of the combination or mixing. If the combination or mixing takes place in such a way that the Client's property is to be regarded as the main action, it shall be deemed to have been agreed that the Client shall transfer co-ownership to Ampco Pumps GmbH on a pro rata basis. The Client shall hold the sole ownership or co-ownership thus created for Ampco Pumps GmbH.
 8. In order to secure the claims of Ampco Pumps GmbH against the Client, the Client shall also assign to Ampco Pumps GmbH the claims which the Client accrues against a third party as a result of the connection of the subject matter of the contract with a piece of land.
 9. Ampco Pumps GmbH undertakes to release the securities to which it is entitled at the request of the Client to the extent that the value of the realizable securities of Ampco Pumps GmbH exceeds the claims to be secured by more than 20%; the selection of the securities to be released is the responsibility of Ampco Pumps GmbH.
- VII. Rights of the Client in the event of defects
1. Ampco Pumps GmbH shall be liable to the Client for ensuring that the subject matter of the contract is free of material defects and defects of title at the time at which the risk passes to the Client. Insignificant deviations from the agreed quality do not constitute a defect. Customary deviations and deviations that occur due to legal regulations or represent technical improvements, as well as the replacement of components by equivalent parts, are also permissible, provided that they do not impair the usability for the contractually intended purpose.
 2. Ampco Pumps GmbH is not liable for defects or damages caused by the following reasons:
Defects that are based on constructions specified or specified by the Client or on materials specified, determined or provided by the Client, including sample materials, or on other provisions provided by the Client.
Defects or damage that occur after the transfer of risk as a result of incorrect or negligent handling, operation by untrained personnel, excessive stress, unsuitable equipment, defective construction work, unsuitable building ground or that occur due to special external influences that are not required by the contract, as well as in the case of non-reproducible software errors.
If improper modifications or repair work are carried out by the client or by third parties, any liability of Ampco Pumps GmbH is excluded for these and the resulting consequences.

3. Ampco Pumps GmbH is also not liable for wear parts (definition to follow) of the subject matter of the contract. Wear is the progressive loss of material from the surface of a solid body, caused by mechanical causes, i.e. contact and relative motion of a solid, liquid or gaseous counterbody. Wear part is a part that is used in places where wear and tear is unavoidable due to operational reasons in order to protect other viewing units from wear and tear and is designed to be replaced.
4. Due to a defect in the subject matter of the contract, which, taking into account numbers 1 to 3 above, gives rise to corresponding claims for defects by the Client, the Client shall initially only have the right to subsequent performance within a reasonable period of time, whereby Ampco Pumps GmbH may choose at its equitable discretion between remedy of defects or replacement delivery. If claims for defects are based on the fact that Ampco Pumps GmbH has fraudulently concealed a defect or has assumed a guarantee for the quality of the object of the contract, the Client shall have the right to choose between remedy the defect or replacement delivery. The expenses required for the purpose of supplementary performance will be borne by Ampco Pumps GmbH. Replaced parts become the property of Ampco Pumps GmbH.
5. Unless the defect requires repair at the installation site, the customer must send the defective parts to Ampco Pumps GmbH for repair or replacement delivery upon request by Ampco Pumps GmbH and at the expense of Ampco Pumps GmbH. In such a case, the obligation of subsequent performance of the Ampco Pumps GmbH with regard to the defective part, if Ampco Pumps GmbH returns the properly repaired part to the customer at its own expense or sends a corresponding spare part. Claims by the Client on account of the expenses necessary for the purpose of subsequent performance, in particular transport, travel, labour and material costs, shall be excluded to the extent that the expenditure increases because the object of the delivery has subsequently been moved to a place other than the Client's establishment, unless the transfer corresponds to its intended use.
6. If the defective part is a product delivered by a third party, the liability of Ampco Pumps GmbH is initially limited to the assignment of the liability claims to which Ampco Pumps GmbH is entitled against the third party. Only after a prior legal claim against the third party by the Client shall the personal liability of Ampco Pumps GmbH be revived. This limitation of liability does not apply if the liability of Ampco Pumps GmbH is based on the fact that Ampco Pumps GmbH has fraudulently concealed a defect or has assumed a guarantee for the quality of the product supplied by the third party.
7. The Client is obliged to inspect the subject matter of the contract immediately upon receipt and to notify Ampco Pumps GmbH of any recognisable defects without delay. This obligation to notify immediately also applies if a defect becomes apparent later. The fact that Ampco Pumps Company is certified according to ISO 9001 does not release the customer from his obligation to inspect and complain in accordance with § 377 HGB. If the Client fails to notify the Client, the subject matter of the contract shall also be deemed to have been approved with regard to the defect.
8. If the Client does not accept the supplementary performance offered by Ampco Pumps GmbH in accordance with the contract, Ampco Pumps GmbH shall be released from liability with regard to the defect complained of after the setting and fruitless expiry of a grace period.
9. In the event of failure of subsequent performance, the Client shall be entitled to assert its other claims for defects in compliance with the contractually agreed conditions, including those resulting from the present General Terms and Conditions of Performance, Sale and Delivery of Ampco Pumps GmbH. In particular, a failure of supplementary performance shall occur if Ampco Pumps GmbH allows a reasonable period of time set by the Client for subsequent performance to elapse without success, or if Ampco Pumps GmbH unduly delays or refuses subsequent performance, or if a reasonable number of attempts at subsequent performance have not been successful.
10. Ampco Pumps GmbH may refuse to remedy the defect if the customer does not meet the agreed payment obligations. The Client may only withhold payments on the merits if a notice of defects is asserted, the justification of which can be beyond doubt. The amount of this right of retention is limited to four times the costs required to remedy the defect. If the Client asserts a claim for defects and it subsequently turns out, in particular after a corresponding investigation by Ampco Pumps GmbH, that the claim for defects asserted by the Client does not exist for factual or legal reasons, Ampco Pumps GmbH shall be entitled to appropriate remuneration and reimbursement of all expenses for its services, in particular in connection with the inspection.
11. For claims for damages, the following limitations, modifications and exclusions in accordance with Section VIII apply.

VIII. Limitation or exclusion of liability of Ampco Pumps GmbH

1. The Client is obliged to carefully observe both the instructions for use and operations as well as the safety instructions of Ampco Pumps GmbH. In particular, the Client must follow the instructions of Ampco Pumps GmbH on how the subject matter of the contract is to be used risk-free, which precautionary measures are to be taken regularly and in individual cases and which misuse is to be avoided. If the Client violates this obligation, Ampco Pumps GmbH shall not be liable for the resulting damage.
2. The limitation of the liability of Ampco Pumps GmbH in the event of defect damage and consequential damage:
Ampco Pumps GmbH is not liable for defect damages (including damages due to loss of profit) and not for consequential damages, regardless of the legal grounds. This exclusion of liability does not apply to claims by the Client for compensation for damages based on gross negligence (intent/gross negligence).
3. The limitation of liability of Ampco Pumps GmbH in the event of simple/slight negligence:
Any claims by the client for compensation for damages, regardless of the legal grounds, which are not based on gross negligence (intent/gross negligence) on the part of Ampco Pumps GmbH, are excluded, provided that the damages are not due to the existence of a defect or to a breach of essential contractual obligations, the fulfilment of which is due to the proper execution of the contract performance of the contract in the first place and on the compliance with which the client regularly relies and may rely (so-called "cardinal obligations").
4. The limitation of the liability of Ampco Pumps GmbH in the event of damages that are not typically foreseeable:
Any claims by the Client for compensation for damages, regardless of the legal grounds, which are not based on gross negligence (intent/gross negligence) on the part of Ampco Pumps GmbH, shall be limited in amount to the compensation of the damage, unless these are already excluded in accordance with the limitation of the liability of Ampco Pumps GmbH in the case of defect damage and consequential damage (number 2) and in the case of simple slight negligence (number 3). Ampco Pumps GmbH at the time of conclusion of the contract, taking into account the circumstances surrounding the Ampco Pumps GmbH knew or should have known, as a possible consequence of the breach of duty and/or contract injury (typically foreseeable damage).
5. The limitation of Ampco Pumps GmbH's liability in the event of a failure to perform:
If the Client asserts a claim for damages against Ampco Pumps GmbH due to a breach of duty or in lieu of performance and if this is not based on gross negligence (intent/gross negligence), this claim for damages is not already excluded in accordance with the limitations of liability in favour of Ampco Pumps GmbH with regard to defect damage and consequential damage (number 2) and in the case of simple slight negligence (number 3) Beyond the limitation of liability of Ampco Pumps GmbH to the typically foreseeable damage (number 4), the amount is limited to a maximum of 10% of the agreed price. A disruption of performance occurs if obstacles arise in the execution of the contractual relationship that make it difficult or impossible to properly fulfil contractual obligations, or if one party to the contract is damaged by the other.
6. The limitation of Ampco Pumps GmbH's liability in the event of damage caused by delay:
The above limitations of liability for the benefit of the Ampco Pumps GmbH with regard to defect damages and consequential damages (number 2), in the case of simple slight negligence (number 3), damages that are not typically foreseeable (number 4) and disruptions to performance (number 5), shall also apply to claims of the Client against Ampco Pumps GmbH for compensation for damage caused by delay, provided that this is not based on gross negligence (intent/gross negligence). In addition, claims for damages by the Client due to delay in delivery as well as claims for damages in lieu of delivery, in all cases of delayed delivery, even after the expiry of any deadline set by Ampco Pumps GmbH for delivery, shall be limited in amount to 0.5% for each completed week of delay, but in total to a maximum of 5% of the price for that part of the deliveries, which could not be put into proper operation due to the delay.
7. The limitation of Ampco Pumps GmbH's liability for its vicarious agents:
Any liability for vicarious agents (§ 278 BGB) of Ampco Pumps GmbH, regardless of the legal grounds, is excluded, unless contractual obligations have been violated by gross negligence (intent/gross negligence) of the vicarious agent, the fulfilment of which makes the proper execution of the contract possible in the first place. In no event shall the liability of Ampco Pumps GmbH for a vicarious agent exceed the liability of Ampco Pumps GmbH for its own negligence, as it arises taking into account the limitations of liability listed above. According to Section 278 of the German Civil Code, a vicarious agent is a natural or legal person whom the debtor uses to meet his obligations.

8. The Client's withdrawal from the contract due to non-performance or non-contractual performance by Ampco Pumps GmbH is excluded. This does not apply if Ampco Pumps GmbH has not provided its services in accordance with the contract intentionally or through gross negligence.
9. The above limitations of liability (numbers 1 to 8) do not apply to claims of the Client due to intentional or grossly negligent conduct, for guaranteed characteristics, for injury to life, body or health or under the Product Liability Act.
10. If the carrier is determined by the customer, Ampco Pumps GmbH shall not be liable for costs arising from additional safety inspections or for time delays resulting from the requirements of the German Aviation Security Act and the EU Regulations (EC) No. 300/2008, (EC) No. 272/2009, (EU) 2015/1998 in their respective valid versions, as well as all other current national and international legal provisions. The Client shall indemnify Ampco Pumps GmbH against all costs and damages on first request, which result from additional safety checks and the resulting time delays.

IX. Prescription

1. If claims for defects are subject to a limitation period of two years under the law (e.g. § 438 para. 1 no. 3 BGB; § 634a para. 1 no. 1 BGB), this limitation period is reduced to one year. Excluded from this shortening of the limitation period are claims for defects by the client due to the assumption of a guarantee for the quality. The limitation period begins with the delivery of the object of the contract and, in the case of an installation obligation on the part of Ampco Pumps GmbH, with the completion of the installation. If the Client is in default of acceptance, the limitation period begins with the occurrence of the default of acceptance.
2. Recourse claims in the supply chain pursuant to Section 445b (1) of the German Civil Code (BGB) shall become statute-barred one year after delivery of the item by Ampco Pumps GmbH to the Client. The suspension of expiry under § 445b.2 of the Civil Code remains unaffected; it ends no later than five years after delivery.
3. In all other respects, the statutory limitation periods apply.

X. Software

Insofar as Ampco Pumps GmbH makes software available to the Client, the following shall apply:

1. Ampco Pumps GmbH grants the Client a non-exclusive right of use to the software provided in accordance with § 31 (2) of the Copyright Act. Section 31 (2) of the Copyright Act reads: "The non-exclusive right of use entitles the owner to use the work alongside the author or other entitled persons in the manner permitted to him." Ampco Pumps GmbH remains the sole owner of all intellectual property rights with regard to the software at all times.
2. The Client shall be entitled to use the software provided to him only on the subject matter of the contract.
3. The Client has no claim to the transfer of the source program/source code.
4. The Client shall be entitled to use the provided software for an indefinite period of time for the entire economic life of the object of the contract.
5. The Client is not entitled to transfer its right of use to third parties, in particular the Client is not entitled to distribute, rent, grant sublicenses to third parties or make them available to third parties in any other way. If the Client transfers its business in its entirety to a third party, the Client is entitled to transfer the granted right of use to the third party. If the customer sells the delivery item in its entirety to a third party in the normal course of business and this third party is not a competitor of Ampco Pumps GmbH, Ampco Pumps GmbH is obliged to agree to a transfer of the granted right of use upon request, unless Ampco Pumps GmbH substantiates that there is a risk that competitors of Ampco Pumps GmbH will become aware of secret knowledge (trade secrets) of Ampco Pumps GmbH.
6. The Client's right of use is not exclusive. Ampco Pumps GmbH is entitled to grant any number of other customers rights of use of any kind with regard to the software provided.
7. The Client may not make the software available or accessible to any third party, except for its employees, not even temporarily or free of charge.
8. The Client may not change the markings, copyright notices and ownership of the software provided in any way.
9. The Client may not make a copy of the provided software, except for the creation of a backup copy by a person authorized to use the program, if this is necessary to secure future use. The backup copy may not be used at the same time as the original software.
10. The Client may not reproduce the documentation belonging to the software in whole or in part by photocopying, microfilming, electronic storage or any other process.
11. Disassembly, reverse engineering or decompilation of the software is prohibited and the Client will neither initiate nor permit this, unless the requirements of § 69e of the Copyright Act are met.
12. All ownership, copyright and other industrial property rights to the software, updates and documentation are owned by Ampco Pumps GmbH. The same applies to changes and translations of the programs.
13. Ampco Pumps GmbH is entitled to carry out necessary software changes at its own expense on the basis of third-party claims of property rights at the Client. The client cannot derive any claims from this.

XI. Export and import controls, embargo regulations

1. The subject matter of the contract may be subject to export and import restrictions, in particular there may be licensing requirements or the use of the object of the contract abroad may be subject to restrictions. In this respect, the Client undertakes to comply with the applicable legal provisions relating to export controls and sanctions lists of the Federal Republic of Germany, the EU and the USA as well as all other relevant regulations. This includes, in particular, the relevant embargo regulations relating to goods, persons and use. These provisions only apply to the extent that they do not contradict the applicable German foreign trade law, the European Blocking Regulation (e.g. § 7 AWV and Art. 5.1 (EC) 2271/96) or national legal bases applicable to the contracting authority.
2. The fulfilment of the contract by Ampco Pumps GmbH is subject to the proviso that there are no obstacles due to national and/or international regulations of export and import law or any other statutory provisions.
3. The resale and/or transfer of the object of the contract, directly or indirectly, to Russia or Belarus is generally prohibited and can only be permitted after a case-by-case examination by Ampco Pumps GmbH.
4. Client further confirms that at this time (a) it has no knowledge of future uses of the subject matter of the Agreement by military customers or customers with military end-uses; (b) there is no knowledge of future uses of the subject matter of the treaty in connection with NBC weapons and launchers; (c) there is no knowledge of future uses of the subject matter of the contract in connection with the construction or operation of nuclear facilities; (d) there is no knowledge of future uses of the subject matter of the contract in connection with the violation of human rights or in connection with actions supporting terrorism.
5. Ampco Pumps GmbH reserves the right to require the Client to sign end-user declarations as part of its own compliance checks, insofar as this is required due to business policy decisions of Ampco Pumps GmbH or legal requirements.

XII. Data protection and data use

1. Ampco Pumps GmbH processes personal data in accordance with the provisions of the European General Data Protection Regulation (GDPR) and the German Federal Data Protection Act (BDSG). Further information on the handling of customer data at Ampco Pumps GmbH can be found at www.krones.com. The Client is obliged to comply with all applicable data protection regulations.
2. Ampco Pumps GmbH is entitled to collect, store, process and evaluate machine data and duly anonymised personal data. This data may be disclosed to the companies affiliated with Ampco Pumps GmbH for the purpose of use for product optimization, performance improvement applications and other services of Ampco Pumps GmbH and/or its affiliates.
3. Ampco Pumps GmbH is entitled to transfer customer data to third parties (including companies affiliated with Ampco Pumps GmbH) if and to the extent that this is necessary to fulfil pre-contractual obligations and to provide contractually agreed deliveries and services (e.g. for shipping, invoicing or customer service) or to comply with legal requirements.

XIII. Place of jurisdiction, applicable law, place of performance, severability clause

1. In the event of all disputes arising out of and in connection with the contractual relationship, the exclusive place of jurisdiction shall be the registered office of Ampco Pumps GmbH if the Client is a domestic merchant, a domestic legal entity under public law or a domestic special fund under public law. For actions against Ampco Pumps GmbH by clients who do not have a general place of jurisdiction in the Federal Republic of Germany, the exclusive place of jurisdiction is also the registered office of Ampco Pumps GmbH. For lawsuits brought by Ampco Pumps GmbH against clients who do not have a general place of jurisdiction in the Federal Republic of Germany, the additional place of jurisdiction is the registered office of Ampco Pumps GmbH in addition to the statutory places of jurisdiction. Any arbitration agreements made by the parties shall take precedence.
2. With regard to the inclusion of these General Terms and Conditions of Performance, Sale and Delivery of Ampco Pumps GmbH and for all legal relationships arising for the contracting parties and their legal successors from the contract and from any ancillary business and/or follow-up business, only the law of the Federal Republic of Germany shall apply. This choice of law and the above jurisdiction agreement are also subject to the law of the Federal Republic of Germany.
The application of the UN Convention on Contracts for the International Sale of Goods (United Nations Convention of 11 April 1980 on Contracts for the International Sale of Goods) is not precluded by the above choice of law.
3. The place of performance is the registered office of Ampco Pumps GmbH.
4. Should the contract or any of the above provisions of these General Terms and Conditions of Service, Sale and Delivery of Ampco Pumps GmbH be or become invalid, this shall not affect the validity of the remaining provisions. Rather, the contracting parties will work together to replace the invalid provision with a legally permissible and effective provision that is suitable for achieving the intended result of the invalid provision. The same applies to the filling of contractual gaps.

Origin of goods (USP): O = goods from third countries 1 = EU origin 2 = EFTA origin

This policy is intended for returns that are not covered by product warranty, i.e. wrong pump or part was ordered, customer canceled order, etc. Before returning any product, contact us for a Returned Material Authorization Number (RMA#). This will eliminate confusion when the parts are received and facilitate processing the return. No action will be taken on returned parts without an RMA.

<u>Type of Return</u>	<u>Restocking Charge</u>
Standard pump with a replacement order	10%
Standard pump without a replacement order	20%
Standard parts with a replacement order	5%
Standard parts without a replacement order	10%

Additional restocking charges may be assessed for any of the following circumstances.

1. Special order motors and seals are not returnable unless we have a use for them. Credit will be determined on a case-by-case basis.
2. Impellers that are trimmed to a diameter that we don't regularly use are not returnable. Credit will be determined on a case-by-case basis.
3. Used seals and motors are not returnable.
4. For any pumps and/or parts purchased over (1) year ago, credit will be determined on a case-by-case basis.

Credits

Credit will be issued only after parts are returned and inspected. Customer is responsible for packaging parts so they are returned in "as new" condition. Any labor required by Ampco to return the parts to "as new" condition will be deducted from the credit.

Certification Information

Ampco Pumps Company



EC Declarations for SP Centrifugal Pump

This document contains two declarations, only one of which is valid for the pump supplied.

The EC Declaration of Incorporation is valid only for pumps sold *without* a motor.

The EC Declaration of Conformity is valid only for pumps sold *with* a motor.

Manufactured by: Ampco Pumps Company
Address: 2045 West Mill Road
Glendale, WI 53209
Tel.: (414) 643-1852
Fax.: (414) 643-4452
E-Mail: info@ampcopumps.com



EC Directives:

All products listed below comply with EC Machinery Directive 2006/42/EC

All products listed below have used Harmonized Standard EN 809:1998+A1:2009 to verify conformance.

For the most specific risks of this machine, safety and compliance with the essential requirements of the Directive has been based on elements of:

- EN ISO 12100-1:2003 / Safety of Machinery - Basic concepts, general principles for design - Part 1: Basic terminology, methodology.
- EN ISO 12100-2:2003 / Safety of Machinery - Basic concepts, general principles for design - Part 2: Technical principles and specifications.
- EN 294:1992 / Safety of machinery - Safety distances to prevent hazard zones being reached by upper limbs
- EN ISO 13857:2008 / Safety of machinery - Guards - General requirements for the design and construction of fixed and movable guards
- EN 809:1998 +A1:2009 / Pumps and pump units for liquids – Common safety requirements

EC Declaration of Incorporation

Valid only for pumps supplied without a motor

We herewith declare that the Ampco Pumps Company product to which this declaration relates is in conformity with the provisions of the Machinery Directive 2006/42/EC. The equipment is a pump designed for liquid transfer applications. The device is not intended to act as a safety accessory.

Per Annex II.B of the Machinery Directive (2006/42/EC):

The machinery, product, assembly or sub-assembly covered by this Declaration of Conformity must not be put into service until the machinery into which it is to be incorporated has been declared in conformity with the provisions of the applicable Directive(s).

EC Declaration of Conformity

Valid only for pumps supplied with a motor

We herewith declare that the Ampco Pumps Company product to which this declaration relates is in conformity with the provisions of the Machinery Directive 2006/42/EC. The equipment is a pump designed for liquid transfer applications. The device is not intended to act as a safety accessory.

The Technical Construction File required by this Directive is maintained at the corporate headquarters of Ampco Pumps Company, 2045 West Mill Road, Glendale, Wisconsin, USA

The authorized representative located within the Community is:

Martin Zierer

[Ampco Pumps GmbH, Gewerbepark West II 7, 76863 Herxheim, Germany, +49 (+9436) 307-710, Martin.Zierer@Evoguard.com

Authorized / Approved By:

Full Name: Martin Zierer

Position: Managing Director

Signature: _____

Date: 04.07.2024

Ampco Pumps Company EC Declaration of Conformity / Declaration of Incorporation

Series:	Model Number:	Description:
SP	SP-210	
SP	SP-215	
SP	SP-220	
SP	SP-225	
SP	SP-240	



Ampco Pumps Company

2045 W. Mill Road

Glendale, WI 53209

Phone: (800) 737-8671 or (414) 643-1852

For additional information on the SP series and other Ampco Pumps products, please visit our website: www.ampcopumps.com